

GENERAL TOOLS	
SPECIAL TOOLS	
MACHINERY	
EQUIPMENT	
MISCELLANEOUS	X

# Alfa Romeo

DIREZIONE ASSISTENZA

## Tool Bulletin

DATE

22-11-1972

SEQUENT NUMBER

1

### INTRODUCTORY NOTE

Purpose of the Tool Bulletin is to enable the service men of the Alfa Romeo After Sales and Service Network to be kept up-to-date with the latest techniques, equipments and all means generally employed to perform servicing and reconditioning work.

The tool bulletins explain and show the use of the special tools, gauges or equipments requiring a particular skill or the technical background peculiar to the operators whom the repair of our product is entrusted to.

The Tool Bulletins are listed in analytical order in an index available as a Service Department publication, which is regularly amended and updated.

We trust this will be helpful to the service men and advise anyone who should have a problem or question to get in touch with the Factory's Service Department.

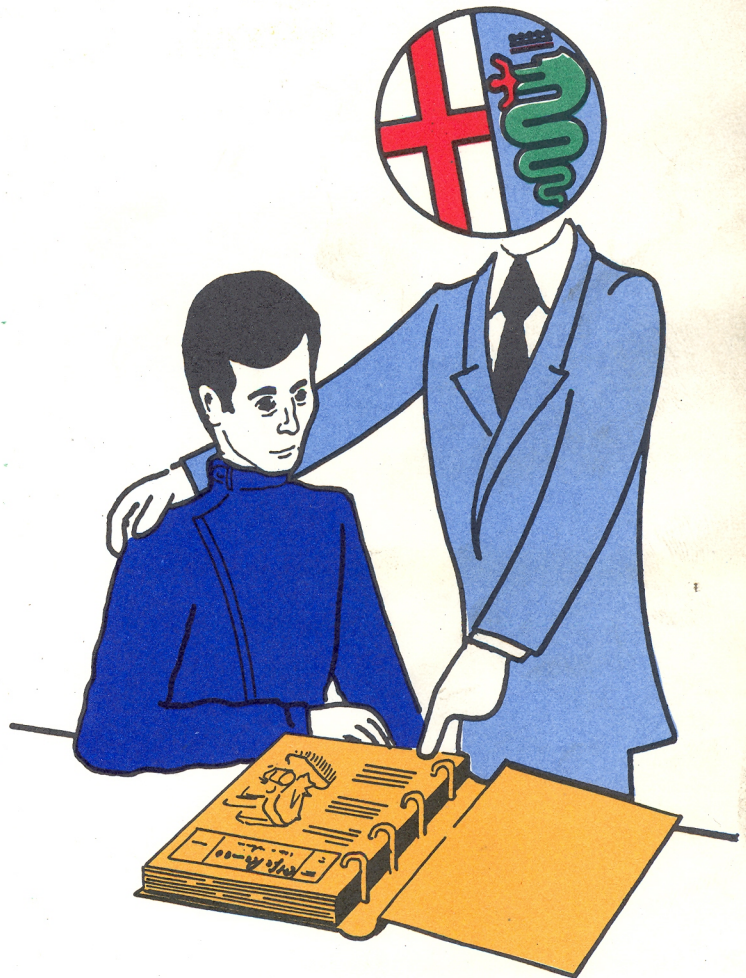

Deleted and supersedes T.B. "INTRODUCTORY NOTE" dated 28/11/1959

GENERAL TOOLS	
SPECIAL TOOLS	<b>X</b>
MACHINERY	
EQUIPMENT	
MISCELLANEOUS	

# Alfa Romeo

DIREZIONE ASSISTENZA CLIENTI

DATE  
30-6-1965

SEQUENT NUMBER  
5/1

Giulietta - 1600  
2600

## Tooling News

### REAMING OF BUSHING IN STEERING BELLCRANK BRACKET

Enlarge the bore of bushings to 24 mm (.9449") by adjusting the ringnuts A and B progressively.

- 1st cut to 23.8 mm (.9370")
- 2nd cut to 23.9 mm (.9409")
- 3rd cut to 23.95 mm (.9428")
- 4th cut to 24.00 mm (.9449")

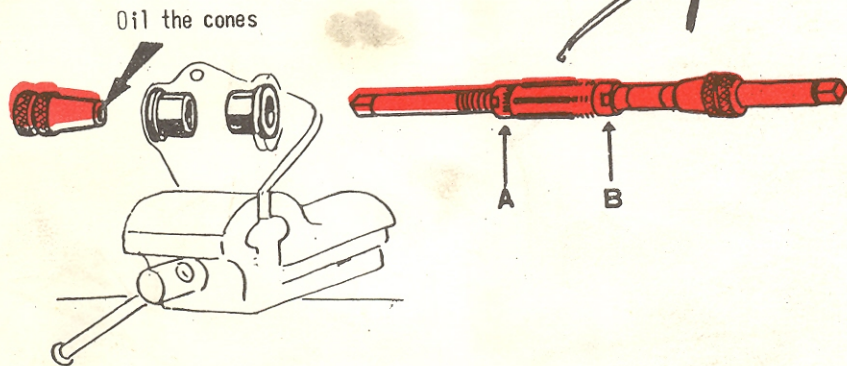

One notch = .01 mm (.0004")

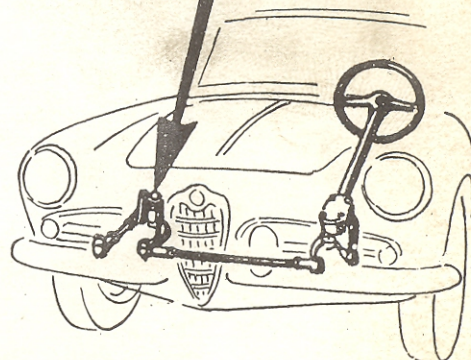
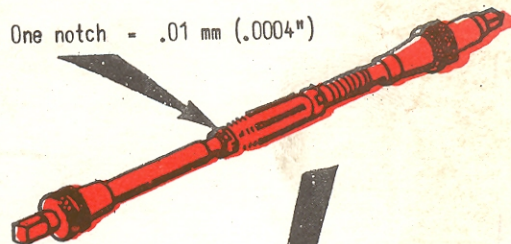

U.2.0016

**1**

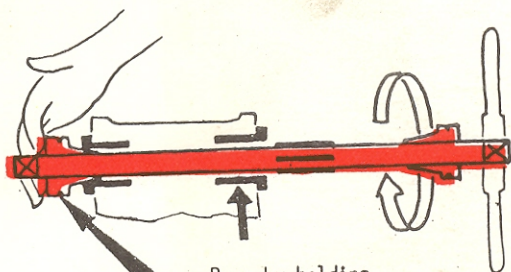

Ream by holding the guide cone in contact with the bushing

**2**

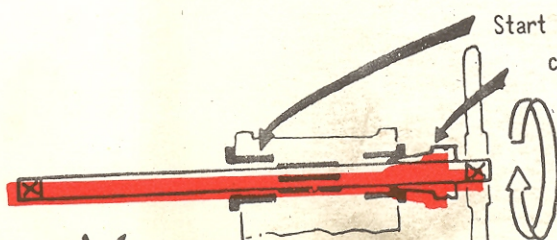

Start to ream the second bushing by inserting the guide cone in the finished bushing

GENERAL TOOLS

SPECIAL TOOLS

X

MACHINERY

EQUIPMENT

MISCELLANEOUS

# Alfa Romeo

## DIREZIONE ASSISTENZA CLIENTI

### Tooling News

DATE  
1-8-1960

SEQUENT NUMBER

6

GIULIA - 2600  
*Giulietta*  
2000

#### ASSEMBLY INNER RING FRONT WHEEL HUB BEARING

A.3.0116  
(*Giulietta*) GIULIA

A.3.0117  
(2000)

2600

1

A spacer of the size shown is required (for unmodified hubs only)

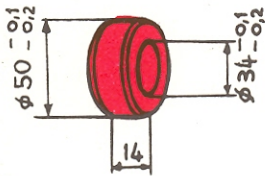

2

Insert punch into complete hub (a = inner bearing, complete - b = oil seal - c = outer ring outer bearing) and drive in with mallet

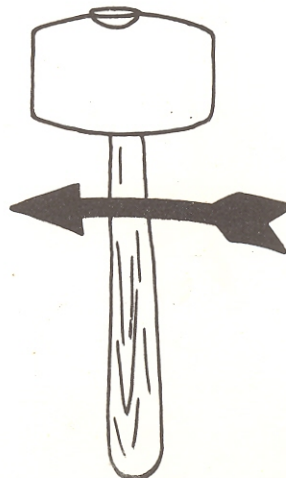
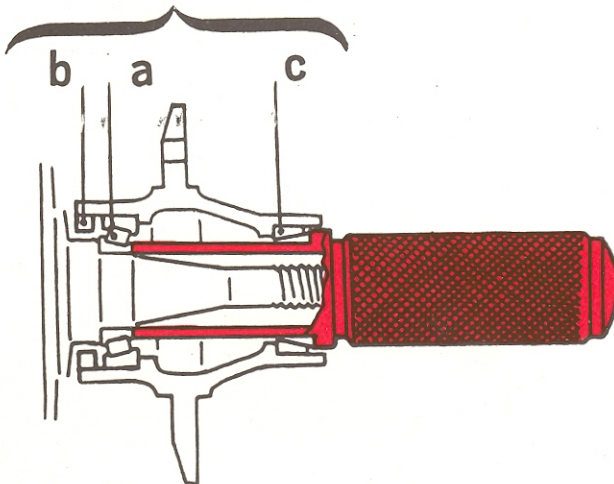
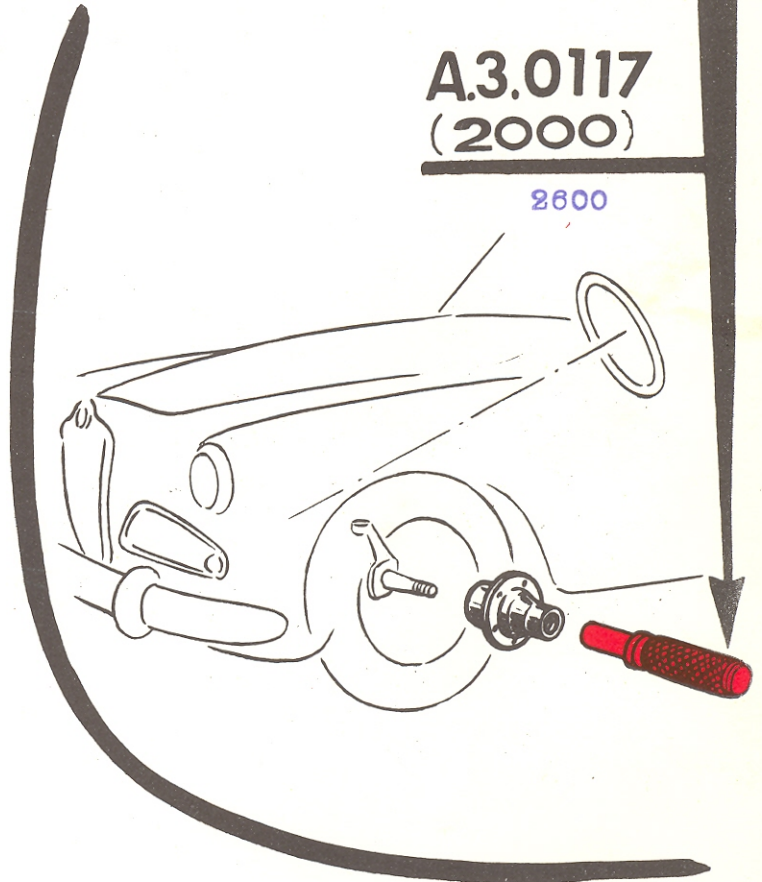

Translated in February 1963

GENERAL TOOLS	
SPECIAL TOOLS	<b>X</b>
MACHINERY	
EQUIPMENT	
MISCELLANEOUS	

*Tool Bulletin*

**Giulietta - Giulia  
2000 - 2600**

DRIVING THE FRONT WHEEL BEARING CONE

**A.3.0116**  
Giulietta - 1600

**1** Only for pre-mod. wheel hubs, use the spacer shown.

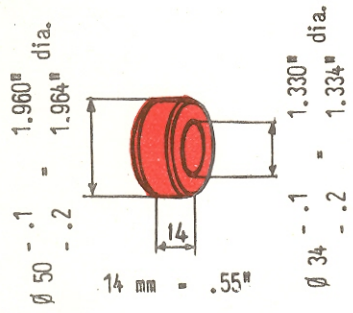

**A.3.0117**  
2000 - 2600

**2** Insert the driver into the hub assembly (a = inboard bearing assy; b = seal; c = out board bearing cup) and drive the cone in place with a mallet.

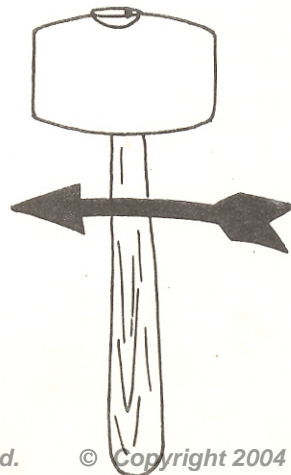
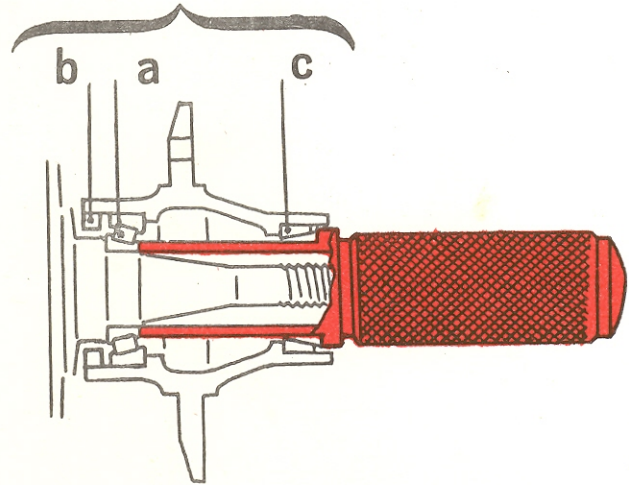
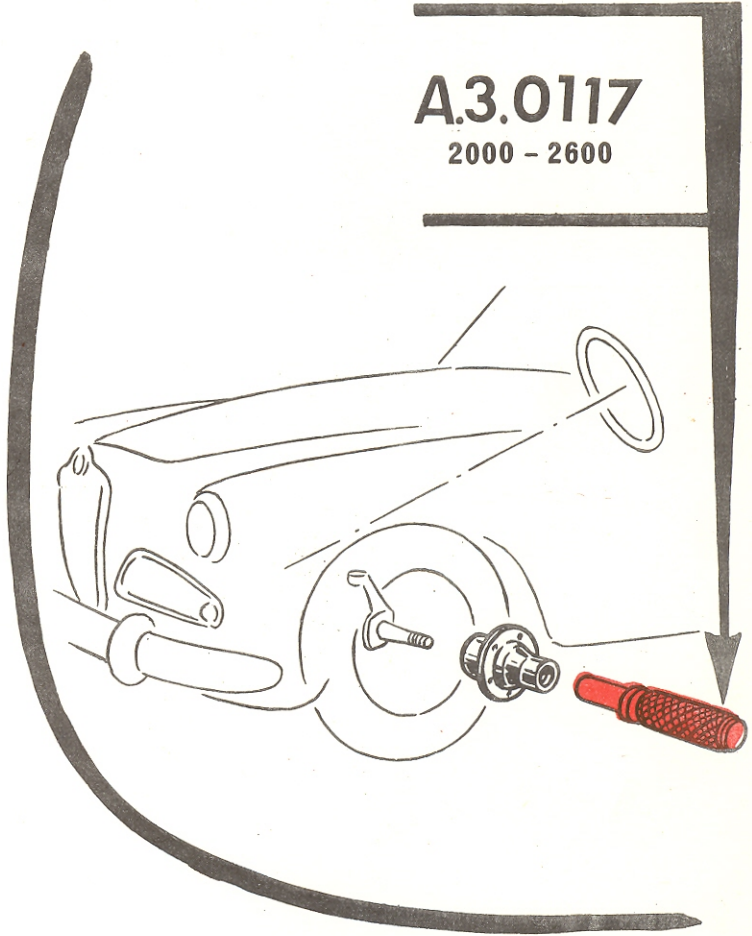

GENERAL TOOLS

SPECIAL TOOLS

X

MACHINERY

EQUIPMENT

MISCELLANEOUS

# Alfa Romeo

DIREZIONE ASSISTENZA

DATE

20-5-1964

SEQUENT NUMBER

8/1

## Tool Bulletin

**Giulietta**

### PULLING THE REVERSE PINION AND BEARING OUT OF LAYSHAFT

## A.3.0050

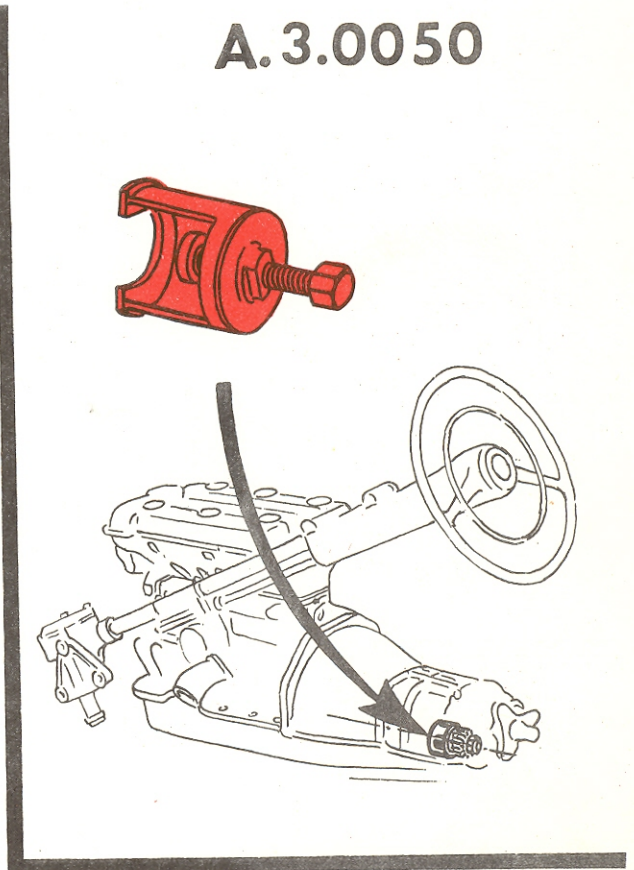
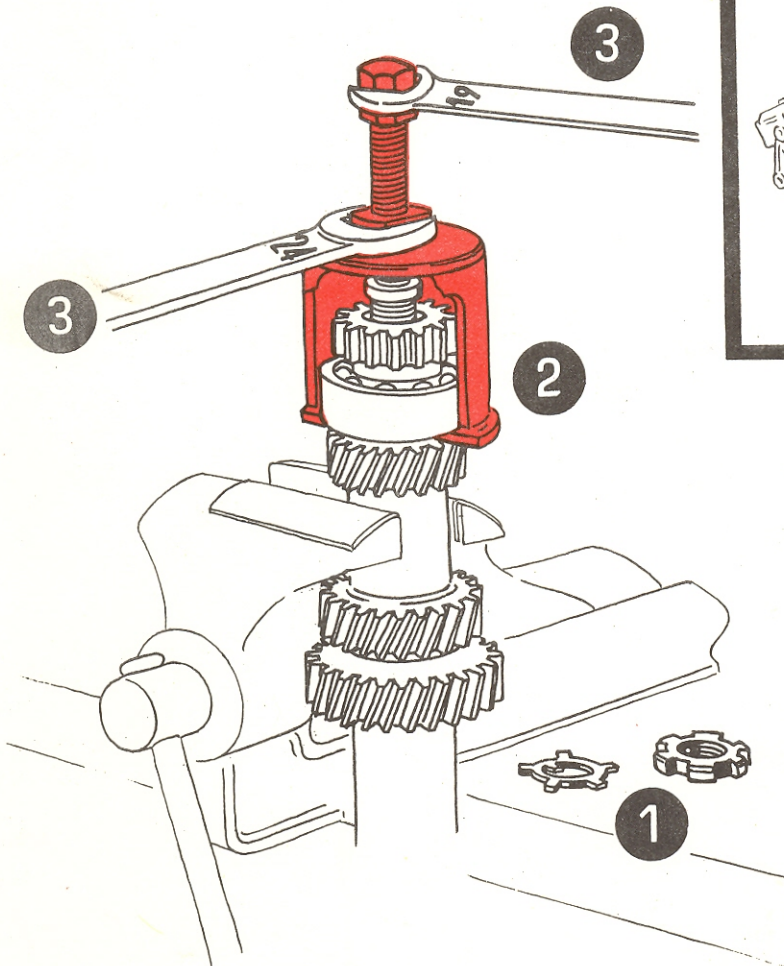

- 1** Remove tabwasher and ringnut;
- 2** Install the tool as shown;
- 3** With the aid of two wrenches (19 mm - 3/4" and 24 mm 15/16") withdraw pinion and bearing.

GENERAL TOOLS

SPECIAL TOOLS

X

MACHINERY

EQUIPMENT

MISCELLANEOUS

# Alfa Romeo

DIREZIONE ASSISTENZA CLIENTI

DATE

30-6-1965

SEQUENT NUMBER

9/1

## Tooling News

**Giulietta**  
**2000 - 2600**

### REAMING OF BUSHINGS IN STEERING BOX BRACKET

**U.2.0017**

**U.2.0018**

	GIULIETTA	2000 - 2600
Enlarge the bore of bushings to	25.38 mm (.9992")	28.57 mm (1.1247")
1st cut to	25.18 mm (.9913")	28.37 mm (1.1169")
2nd cut to	25.28 mm (.9952")	28.47 mm (1.1208")
3rd cut to	25.33 mm (.9973")	28.52 mm (1.1228")
4th cut to	25.38 mm (.9992")	28.57 mm (1.1247")

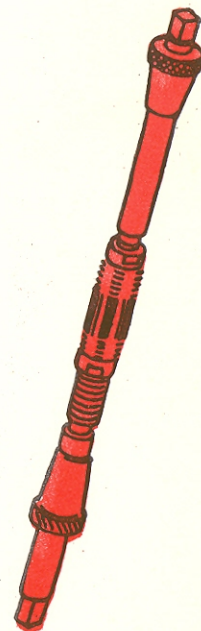

➔ For proper use of reamers refer to Tooling News No. 5/1

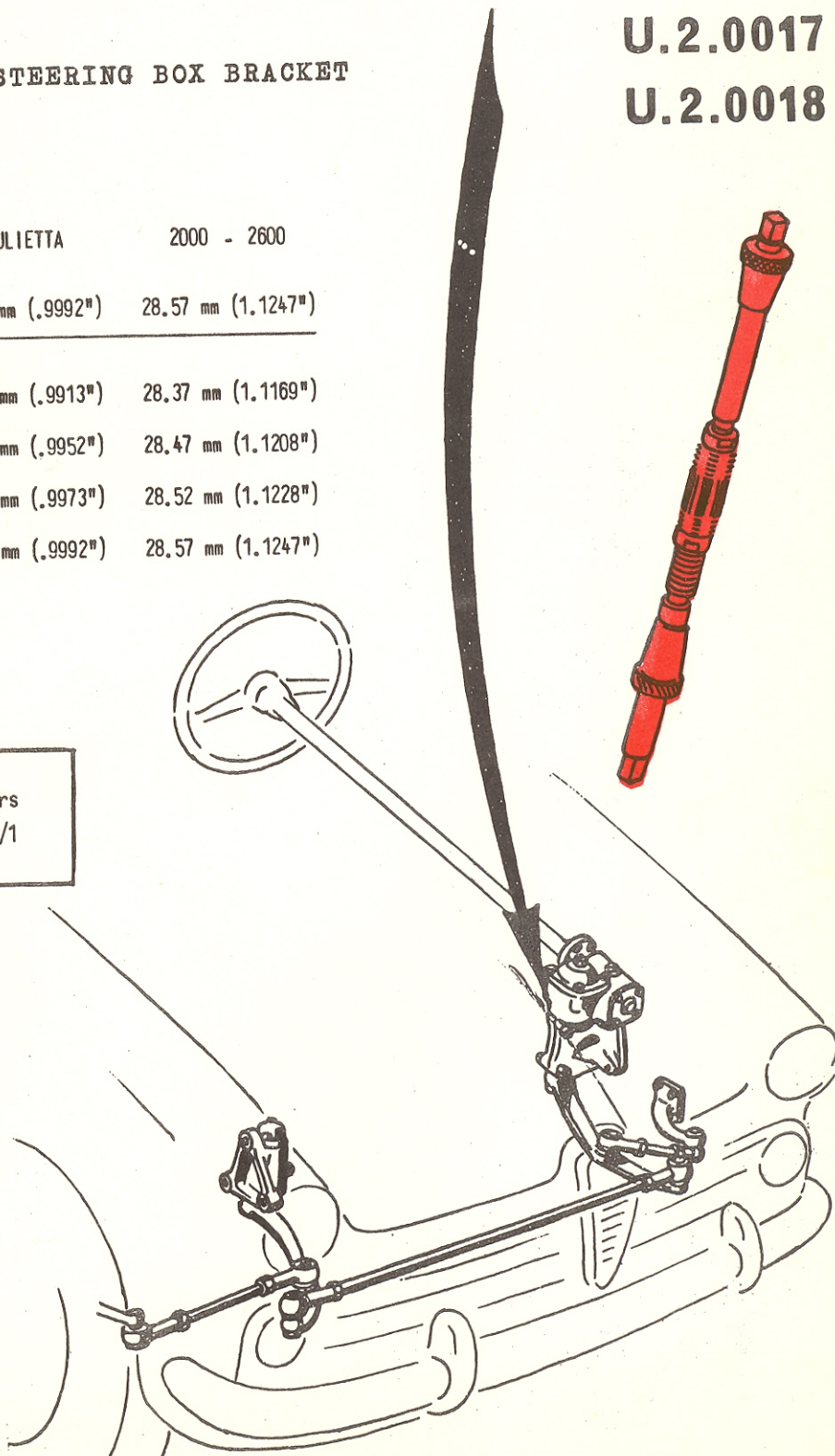

GENERAL TOOLS	
SPECIAL TOOLS	X
MACHINERY	
EQUIPMENT	
MISCELLANEOUS	

# Alfa Romeo

DIREZIONE ASSISTENZA

## Tool Bulletin

DATE  
20-5-1964

SEQUENT NUMBER  
11/2

**Giulietta - Giulia**  
**2000 - 2600 - Mille**  
**1625 - 1627**

### REMOVAL AND INSTALLATION OF VALVE COTTERS

#### Vehicle engines

- 1 Fit the anchor "A" of the type as applicable on a pair of cylinder head studs and secure with nuts.
- 2 Connect the yoke "B" of the type as applicable to the lever "C" by inserting the pivot pin "D" through the slot in the lever and securing with the split pin "E".
- 3 Position the lever so assembled in such a way as to engage the anchor "A" as shown; then operate lever "C" to compress the springs and remove cotters.

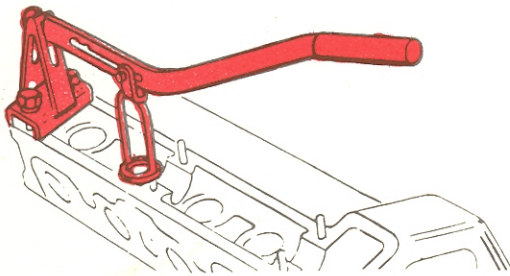

#### Industrial engines

- 4 Screw the anchor "T" into the threaded hole in the head;
- 5 Assemble the yoke A.3.0103/9 to the lever as per 2 above;
- 6 Position the lever so assembled in such a way as to engage the anchor "T" as shown; then operate lever "C" to compress the springs and remove cotters.

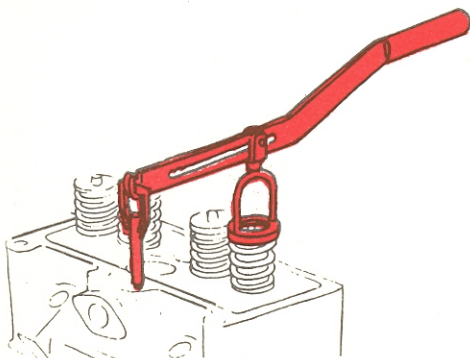

N.B. - This can be made also with the engine in the vehicle, taking care to bring the concerned piston to T.D.C. in order to avoid the valves from dropping in the cylinder.

**A.3.0103/1** All types

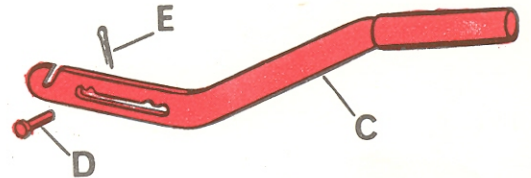

#### Cars



**A.3.0103/2** Giulietta - Giulia  
2600



**A.3.0103/3** 2000



**A.3.0103/5** Giulietta 31 mm dia.  
**A.3.0103/6** Giulietta } 34,5 mm  
**A.3.0103/7** Giulia } dia.  
**A.3.0103/8** 2000  
**A.3.0103/8** 2600

#### Industrial engines

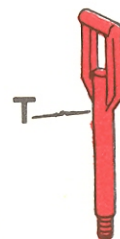

**A.3.0103/4**



**A.3.0103/9**

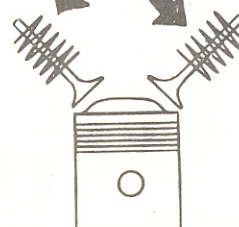

GENERAL TOOLS	
SPECIAL TOOLS	<b>X</b>
MACHINERY	
EQUIPMENT	
MISCELLANEOUS	

*Alfa Romeo*  
DIREZIONE ASSISTENZA

*Tool Bulletin*

DATE	22-11-1972
SEQUENT NUMBER	<b>11/4</b>
Giulia - 1750 - F 12 2000 - Montreal Alfetta - Alfasud	

## REMOVING AND REFITTING CYLINDER HEAD VALVES

**A.3.0324**

(All models)

- 1** Lock the cylinder head in a vice by means of the tools described in the T.B. no. 76.
- 2** Fit the applicable support "A" to two cylinder head studs and lock it in place with two nuts.
- 3** Connect the yoke "B" to the lever "C" by means of the bolt "D" and the wingnut "E".
- 4** Engage the lever so assembled with the pin in the support "A" as shown; then, act on the lever "C".

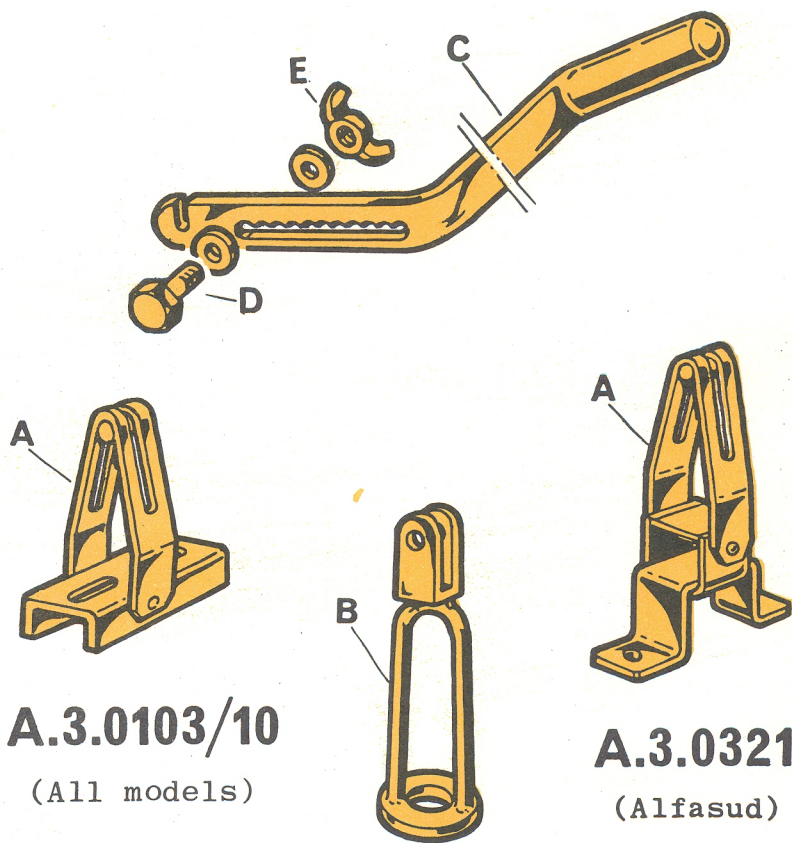

**A.3.0103/10**

(All models)

**A.3.0321**

(Alfasud)

**A.3.0103/6**

(All models)

N.B. For valve clearance adjustment only, the work can be done without removing the head from the engine. To avoid the valves from dropping into the cylinder, bring the piston to the T.D.C.

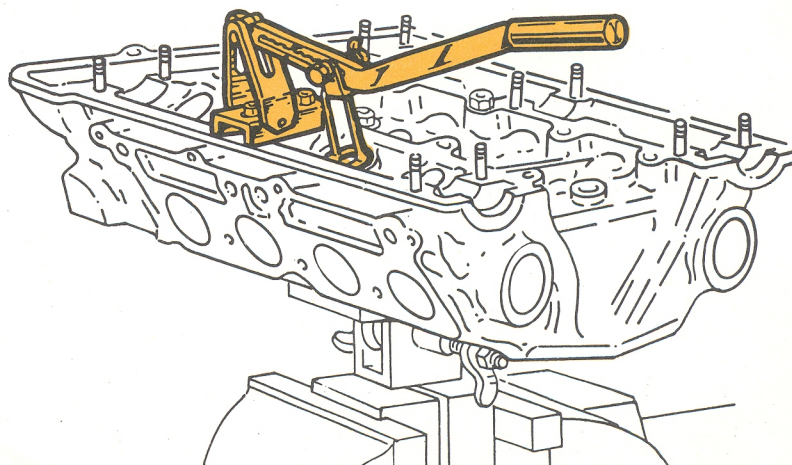

Deletes and supersedes T.B.  
No. 11/3 dated 25/5/1971

GENERAL TOOLS

SPECIAL TOOLS

X

MACHINERY

EQUIPMENT

MISCELLANEOUS

# Alfa Romeo

## DIREZIONE ASSISTENZA CLIENTI

DATE

30-6-1965

SEQUENT NUMBER

18/1

### Tooling News

Giulietta  
2000 - 2600

#### WITHDRAWAL OF STEERING WHEEL

### A.3.0104

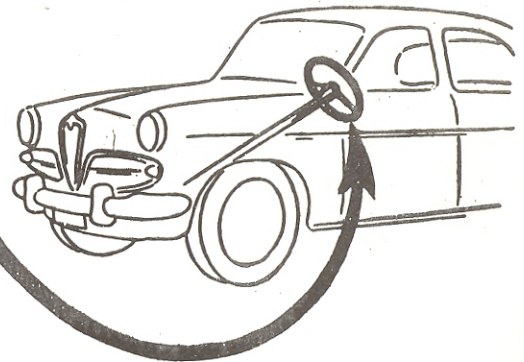
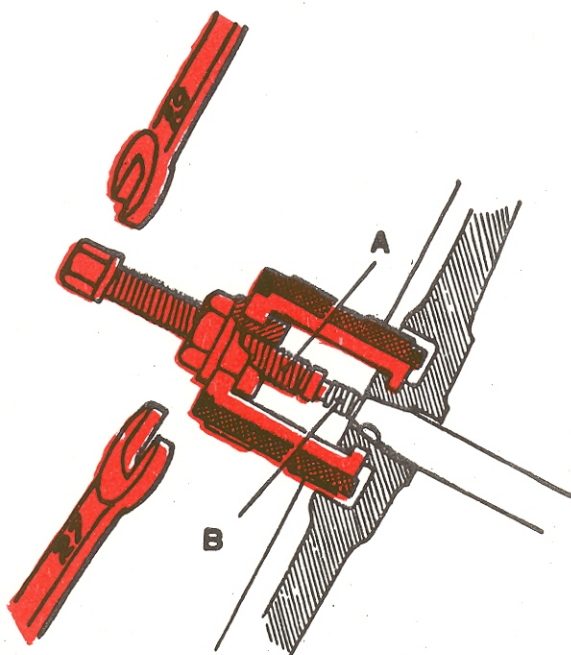
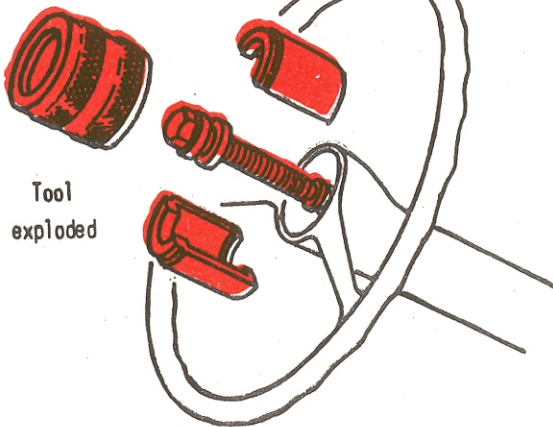

1

Fit the tool.

2

With a 19 mm (3/4") hex. wrench bring the screw "A" in contact with the end "B" of steering shaft.

3

Then, by using the same wrench, withdraw the wheel holding the tool with a 27 mm (1 1/16") hex. wrench.

GENERAL TOOLS	
SPECIAL TOOLS	X
MACHINERY	
EQUIPMENT	
MISCELLANEOUS	

# Alfa Romeo

DIREZIONE ASSISTENZA

DATE  
10-9-1963

SEQUENT NUMBER  
20/1

Giulietta - Giulia

2000 - 2600

## Tool Bulletin

### CHECKING THE BEARING PRE-LOAD AND THE FINAL DRIVE BACKLASH

C.5.0100

1

Install the tool on the pinion shaft yoke; to do this, insert two studs (applicable to the model of car being tested as per model name stamped on the tool center plate) in to diametrically opposite holes of the yoke.

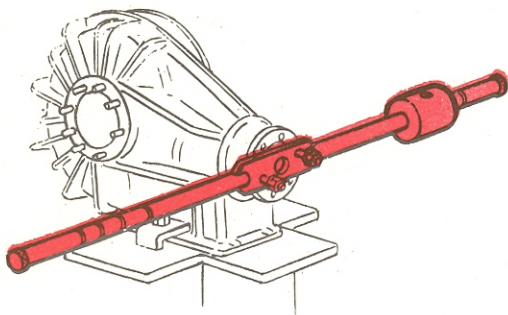

2

Secure with washers and nuts, "A".

3

Slide the weight "B" onto the R.H. arm as viewed from the yoke end. To insert or withdraw the weight from the tool arms, remove stops "C".

4

Rotate the tool clockwise and counterclockwise to settle the bearings; then return the arms in horizontal position.

5

Check the preload by positioning the weight in the proper slot. Slot "P" is for checking the pre-load of "pinion" bearings only and slot "T" for the "total" pre-load of pinion bearings plus differential bearings.

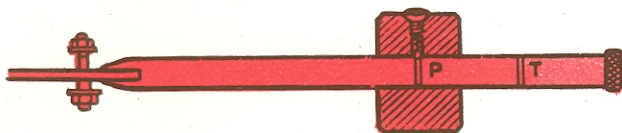

6

Swing the tool in both directions once or twice; then check the pre-load that is correct when, leaving the tool arms free in horizontal position, the weight moves downward slowly through about 30 degrees.

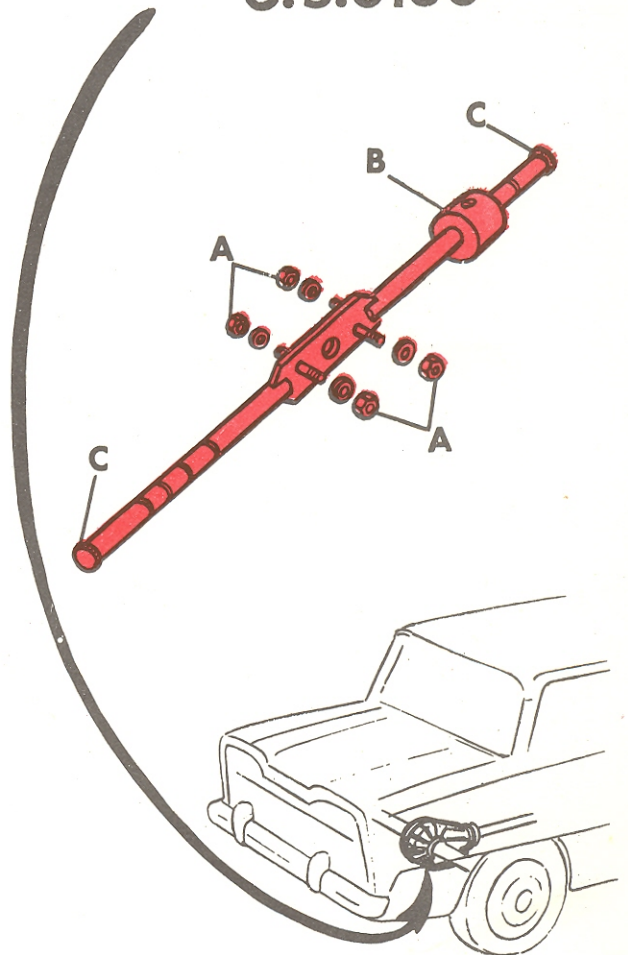

7

To check the final drive backlash on Giulietta and Giulia models, have the sensing rod of a dial indicator resting against the tool center plate in correspondence of the reference mark (45 mm apart from pinion  $\odot$ ) and compare the readings so obtained with the values given in the Shop Manual.

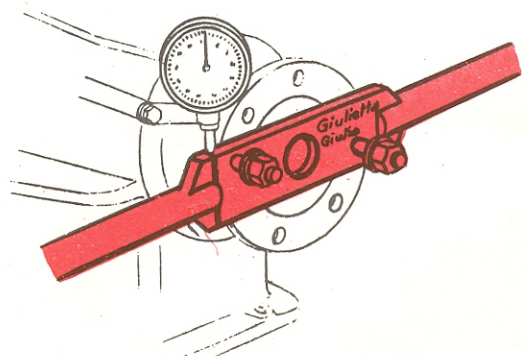

GENERAL TOOLS	
SPECIAL TOOLS	X
MACHINERY	
EQUIPMENT	
MISCELLANEOUS	

# Alfa Romeo

DIREZIONE ASSISTENZA

## Tool Bulletin

DATE	1-6-1973
SEQUENT NUMBER	20/2
All models	

### CHECKING THE BEARING PRE-LOAD AND THE FINAL DRIVE BACKLASH

C.5.0100

CHECKING THE BEARING PRE-LOAD AND THE FINAL DRIVE BACKLASH (Giulia - 1750 - 2000 and Montreal models)

- The tool C.5.0100 consists of two arms welded to a centre plate on which four studs (two each plate face) are conveniently positioned; their use is in accord to the car model being tested.

For proper use, a mark of the models to which the studs apply, is metal stamped next to the studs themselves (shown by "A" at the fig. 1).

The tool is completed by the weight "B" and the stops "C". Reference marks for each car model are cut in the tool arms (see fig. 4).

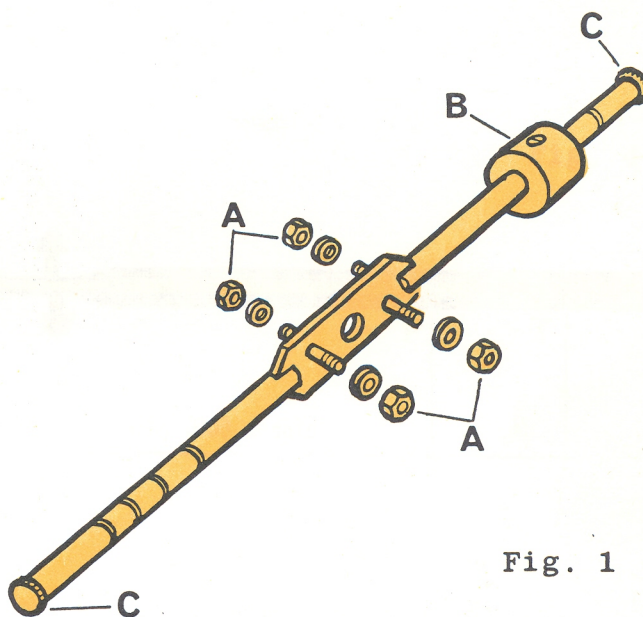

Fig. 1

- Fit the tool to the pinion shaft yoke; to do so, insert the two studs "A" as applicable into the relevant holes in the yoke; then, secure the tool in place (see figure 2). On Montreal model, use the tool A.2.0210 (shown at fig. 3) which acts as an adaptor for the tool C.5.0100.

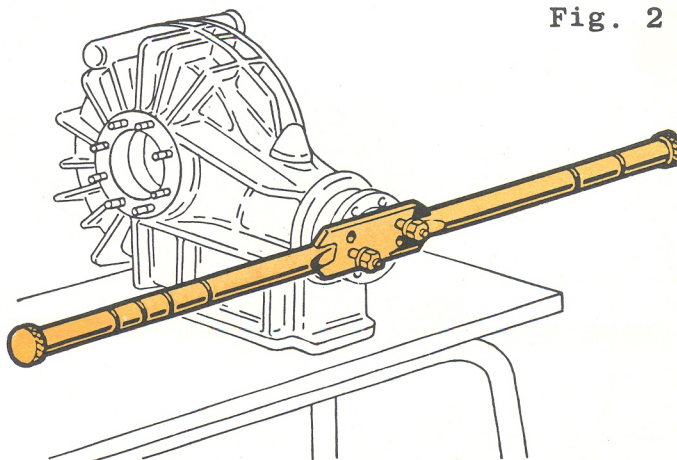

Fig. 2

Deletes and supersedes I.B.  
 No. 20/1 dated 10/9/1963

- 3 Bring the arm applicable to the model being tested to the R.H. side (operator's right side when he is facing the tool); it should be born in mind that the grooves in the tool arms marked "P" must be used for checking the pre-load of pinion bearings only; the grooves marked "T" must instead be used for checking the total pre-load of bearings of pinion when matched to the crown wheel. See fig. 4.

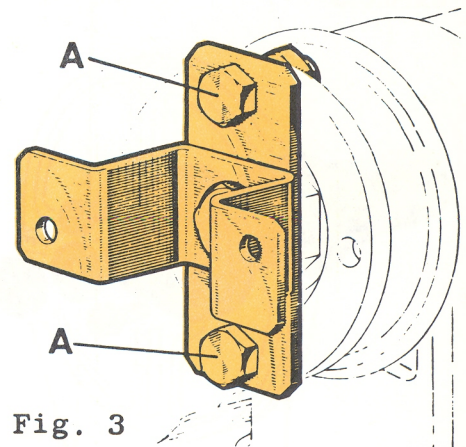

Fig. 3

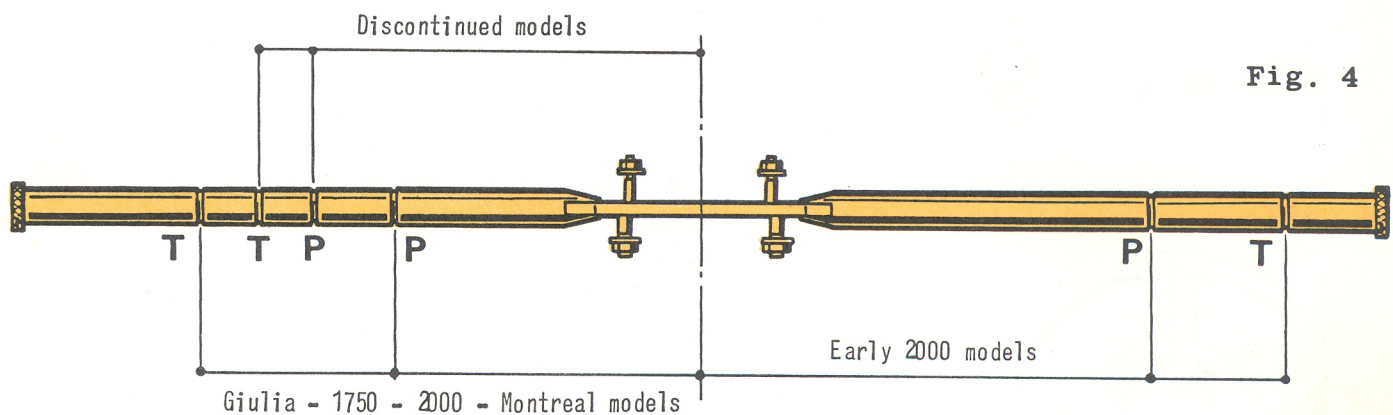

Fig. 4

- 4 Remove the stop "C" and slide the weight "B" on the arm to the position required (e.g. "P"). See fig. 5.

For the checking procedure refer to the Shop Manual.



Fig. 5

- 5 Swing the tool in both directions once or twice; then check the pre-load. It is correct when, on leaving the tool arms free in horizontal position, the weight moves downward slowly through about 30 degrees. See fig. 6.

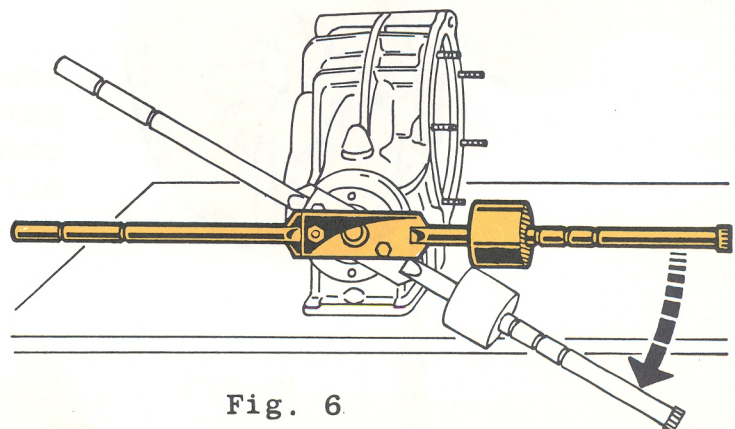

Fig. 6

ALFETTA and ALFASUD models

- 6 The tool C.5.0124 complete with the weights C.2.0037 is common to both the above mentioned models.

On the Alfetta model, fit the above said tool to the spindle C.5.0123 and secure it with the two screws "D" as shown in figure 7.

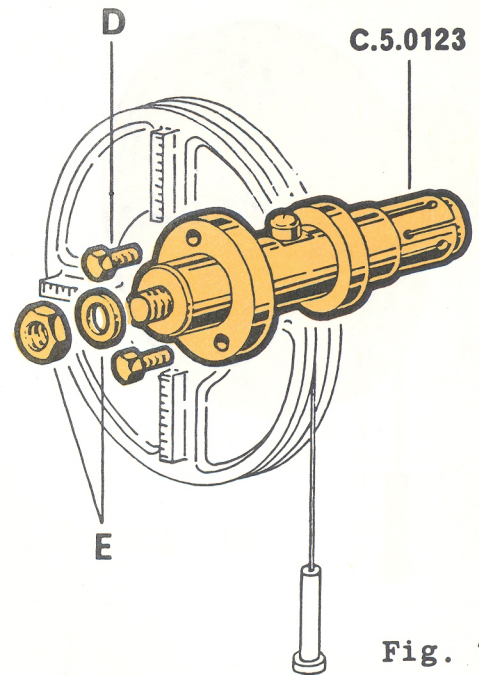

Fig. 7

- 7 Insert the spindle into the splined bore in the differential carrier and secure it in place with washer and nut "E". See fig. 7.

- 8 Check whether the torque to turn the bearings falls within the limits specified in the Shop Manual. To this end, proceed as shown at the fig. 8 by applying the appropriate weight C.2.0037 to the end of the cable.

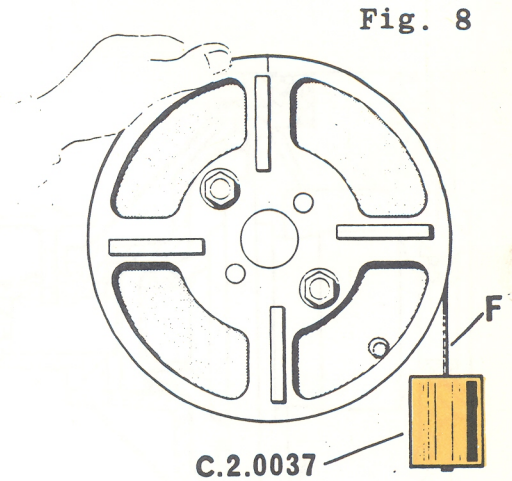

Fig. 8

- 9 On the Alfasud model, in order to check the torque to turn the pinion shaft, fit the adaptor A.2.0274 to the tool C.5.0124 and secure them together with the screws "G". See fig. 9.

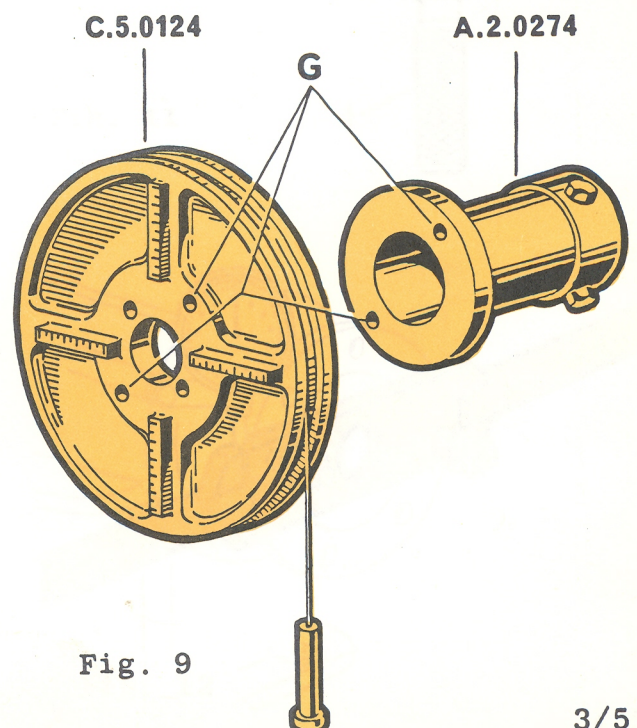

Fig. 9

**10** Fit the tool so assembled to the end of pinion shaft and secure it in place by tightening the three setscrews "H" of the tool A.2.0274. See fig. 10.

**11** Carry out the check as directed by the parag. 8.

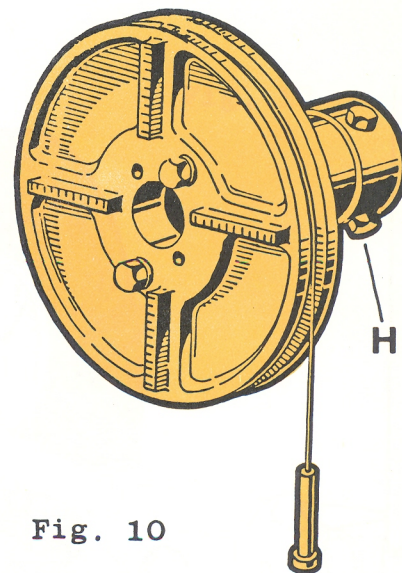

Fig. 10

### CHECKING THE FINAL DRIVE BACKLASH

#### Giulia - 1750 - 2000 and Montreal models

**12** Refer to the Tool Bulletin 102, and specifically to the fig. 2. Lock the crown wheel by means of the setscrew "H". See figure 11. Then, fit the tool C.5.0100 to the pinion shaft yoke as directed by paragr. 2.

**13** Have the stylus of a dial gauge, previously mounted to a magnetic support, resting on the edge of the plate of tool C.5.0100 at the reference slot (see fig.12) and pre-set the gauge needle to about one millimetre.

**14** Check whether the backlash is as specified by proceeding as directed in the Shop Manual.

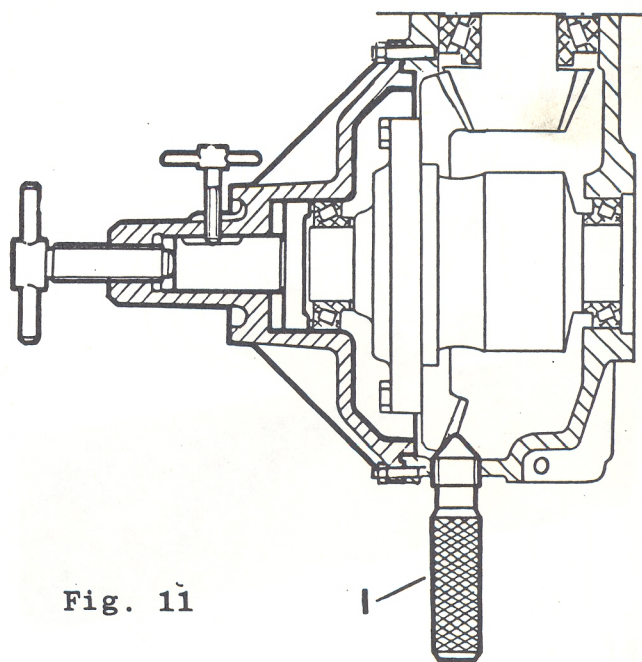

Fig. 11

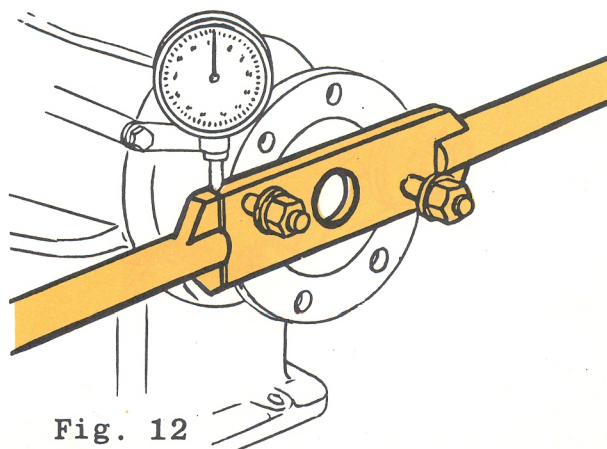

Fig. 12

ALFETTA model

- 15 Carry out the preliminary steps as stated in the Shop Manual for checking the back lash.

To use the tools follow the directions given in the paragraphs 6 and 7.

- 16 Place the stylus of a dial gauge in such a position against one of the four calibrated lugs of tool C.5.0124 (see fig.13) as to align the stylus with the mark corresponding to the crown wheel mean diameter. Pre-set the gauge needle to 1-2 millimetres.

- 17 Swing the tool in both directions and check whether the backlash is as specified in the Shop Manual.

ALFASUD model

The final drive backlash is directly checked by means of a dial gauge whose stylus rests against the outer end of the crown wheel tooth as shown at fig. 15.

Prior to perform this check, the pinion must be locked with the tool A.2.0243 shown at fig. 14.

For the checking procedure refer to the Shop Manual.

Fig. 13

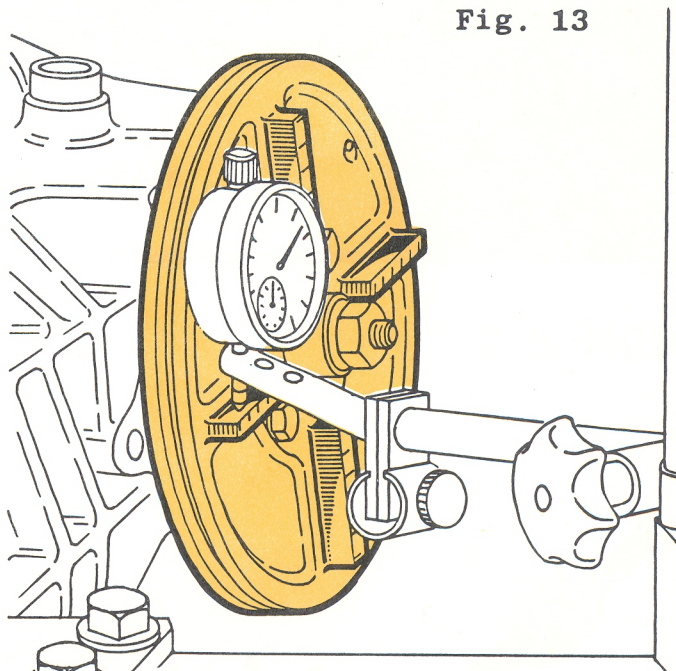

A.2.0243

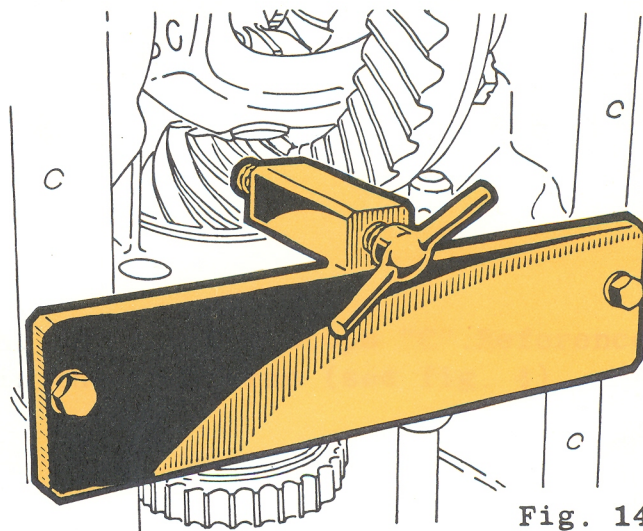
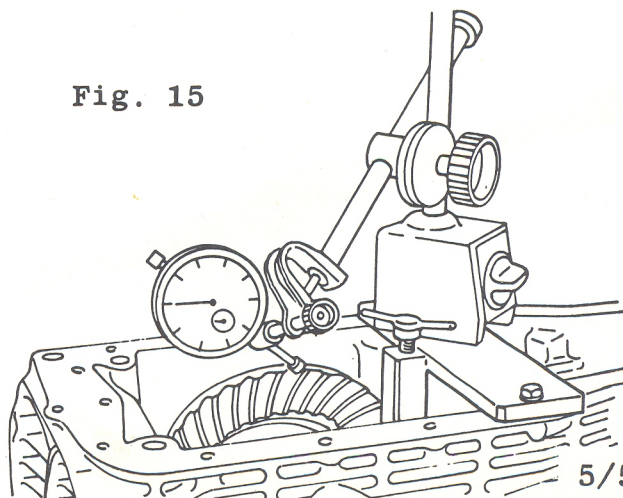

Fig. 14

Fig. 15



GENERAL TOOLS	X
SPECIAL TOOLS	
MACHINERY	
EQUIPMENT	
MISCELLANEOUS	

# Alfa Romeo

DIREZIONE ASSISTENZA

DATE

20-5-1964

SEQUENT NUMBER

22/1

## Tool Bulletin

**Giulietta - Giulia  
2000 - 2600**

### DISASSEMBLY OF STANDARDIZED GEARBOX MAINSHAFT

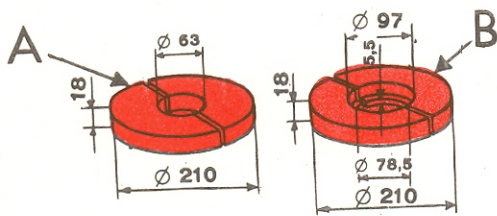

18 mm	=	.71"
63 mm	=	2.48"
210 mm	=	8.27"
5,5 mm	=	.22"
97 mm	=	3.82"
78.5 mm	=	3.09"

- 1** Locally manufacture "A" and "B" according to dimensions shown.

#### DIRECT DRIVE SHAFT

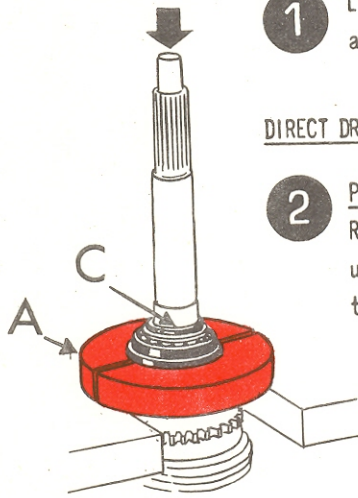

- 2** Pulling the bearing  
Remove the retainer ring "C" and using half-plates "A" withdraw the bearing.

#### MAINSHAFT

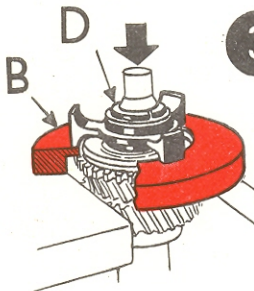

- 3** Pulling the 3rd & 4th gear synchronizing hub  
Remove the retainer ring "D", place the half-plates "B" under the hub and press off the hub.

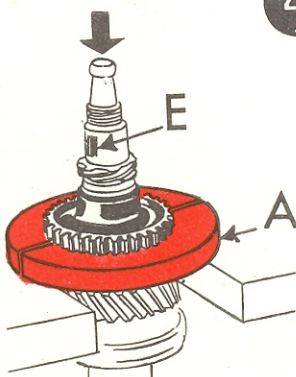

- 4** Pulling the reverse gear  
Withdraw the key "E"; fit the half-plates "A" and press off the gear.

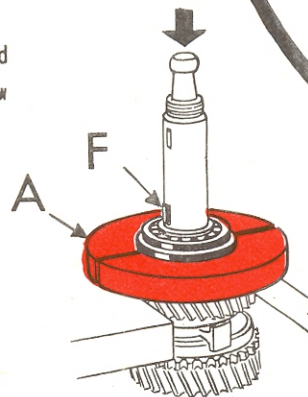

- 5** Pulling the rear bearing  
Withdraw the key "F", fit the half-plates "A" and press off the bearing.

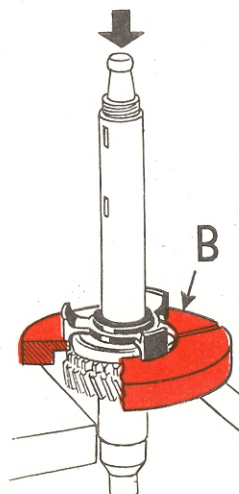

- 6** Pulling the 1st & 2nd gear synchronizing hub  
Place the half-plates "B" under the hub and press off the hub.

#### HYDRAULIC PRESS

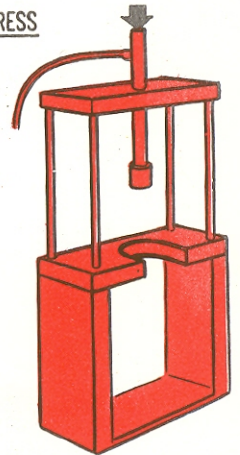

Use a press with a bed plate like that shown in the sketch (i.e. having a relief for the shafts). If not available, provide means suitable for this purpose.

#### REASSEMBLY

The two synchronizing hubs and the rear bearing should be heated to 120°-130°C (248°-266°F) in oil and reinstalled by hand. The reverse gear should be refitted with the aid of a mallet.

GENERAL TOOLS

SPECIAL TOOLS

X

MACHINERY

EQUIPMENT

MISCELLANEOUS

*Alfa Romeo*

DIREZIONE ASSISTENZA

*Tool Bulletin*

DATE

20-5-1964

SEQUENT NUMBER

24 / 1

**Giulietta - Giulia  
2000 - 2600**

**A3.0114**

PROTECTING THE CLUTCH HOUSING SEAL  
(during the reassembly of clutch housing to gearbox)

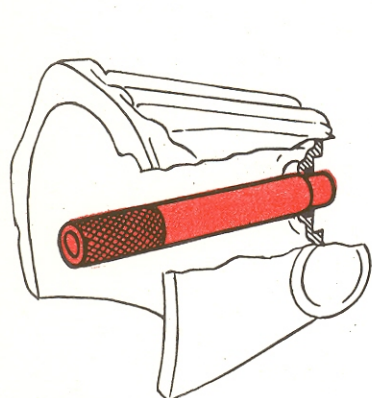

1

Insert the tool into the seal.

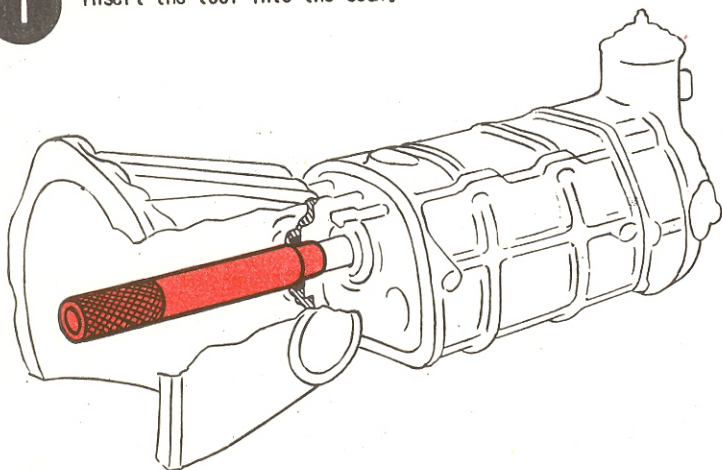

2

Fit the clutch housing to the gearbox in such a way as to engage the tool with the input shaft.

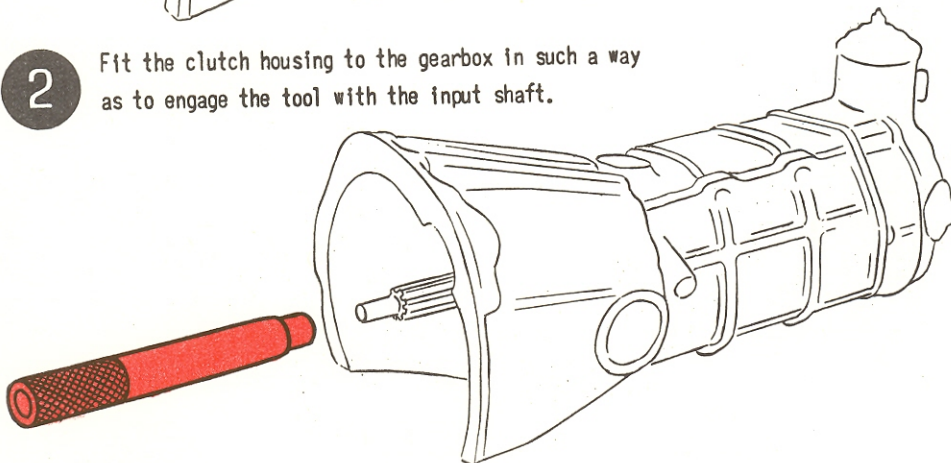

3

Withdraw the tool.

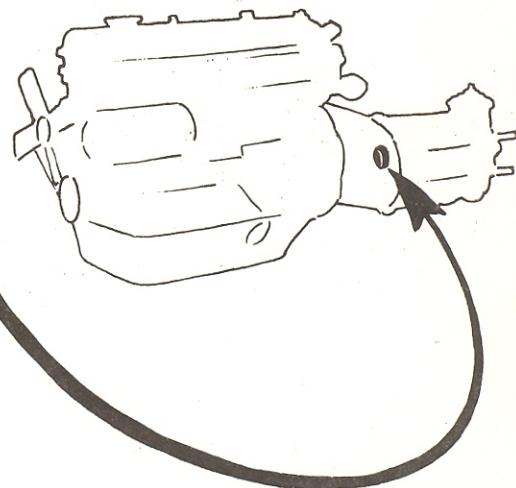
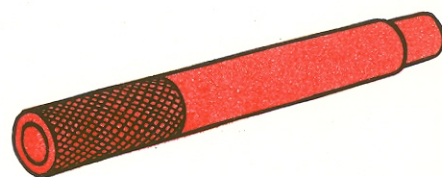

GENERAL TOOLS

SPECIAL TOOLS

X

MACHINERY

EQUIPMENT

MISCELLANEOUS

# Alfa Romeo

DIREZIONE ASSISTENZA CLIENTI

DATE

1-3-1969

SEQUENT NUMBER

27/2

## Tooling News

Giulia - 1750

### CHECKING THE DISTANCE OF FINAL DRIVE PINION FROM RING GEAR ⌘

### C.5.0116

- 1 Zero set the dial indicator, fixed to the support C.5.0116, against the reference gauge C.6.0101

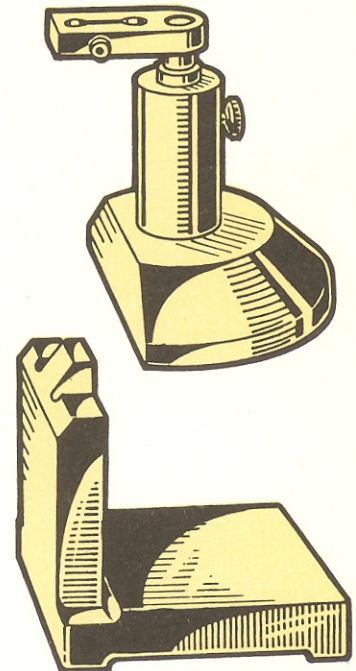
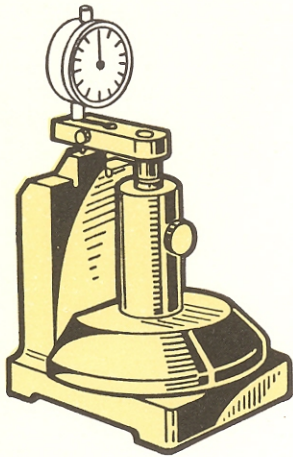

### C.6.0101

- 2 Place the dummy shaft C.6.0114 in the differential carrier bearing seat and tighten nut "A" by hand

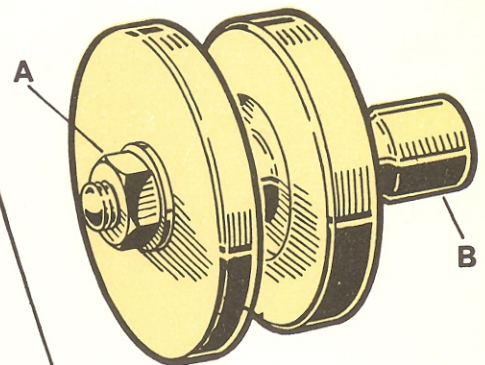
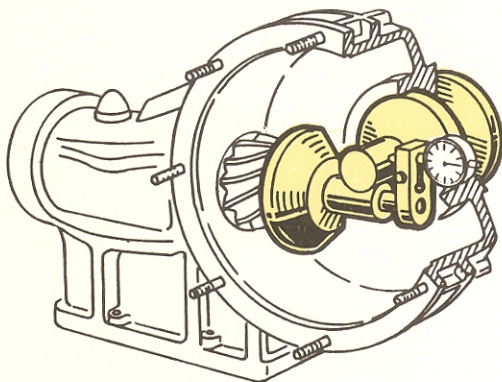

### C.6.0114

- 3 Rest the dial indicator support against the pinion top and check that, by sliding the needle along the barrel "B" of dummy shaft, the negative or positive readings are in accordance with the figure stamped on the pinion itself

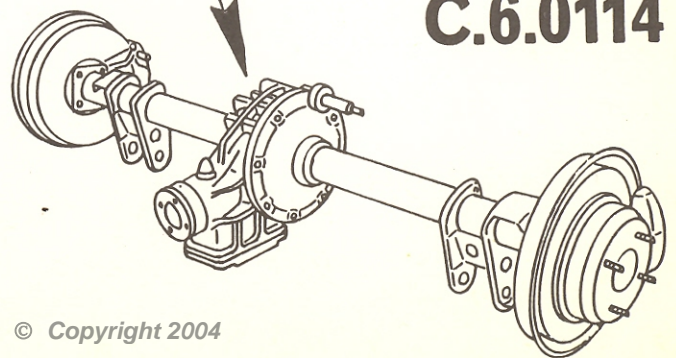

This Bulletin deletes and supercedes T.B. no 27/1 dated 20/5/64

GENERAL TOOLS	
SPECIAL TOOLS	X
MACHINERY	
EQUIPMENT	
MISCELLANEOUS	

# Alfa Romeo

DIREZIONE ASSISTENZA

## Tool Bulletin

DATE

10-9-1973

SEQUENT NUMBER

27/5

All models

### CHECKING THE DISTANCE OF FINAL DRIVE PINION FROM RING GEAR ⌘

**1** To accomplish the checking procedure three special tools for each car model are needed:

- Support (figg. 1 and 8);
- Reference gauge (figg. 2 and 7);
- Dummy shaft (figg.4 and 5).

For applicability of tools to the car models, refer to the relevant tables.

Fit a dial gauge, with a scale 40/45 mm in range, into the clamp "A" of the support and tighten in place with a set-screw "B".

**2** Zero set the dial gauge against the applicable reference gauge (see fig. 2) by adjusting in height the column "C"; tighten in place with the setscrew "D".

Pre-set the dial gauge by 1 mm  
See fig. 3.

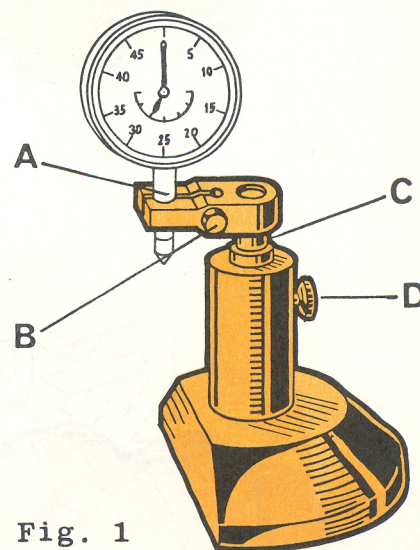

Fig. 1

ALFETTA - ALFASUD	GIULIA - MONTREAL 2000
A.4.0136	C.5.0116

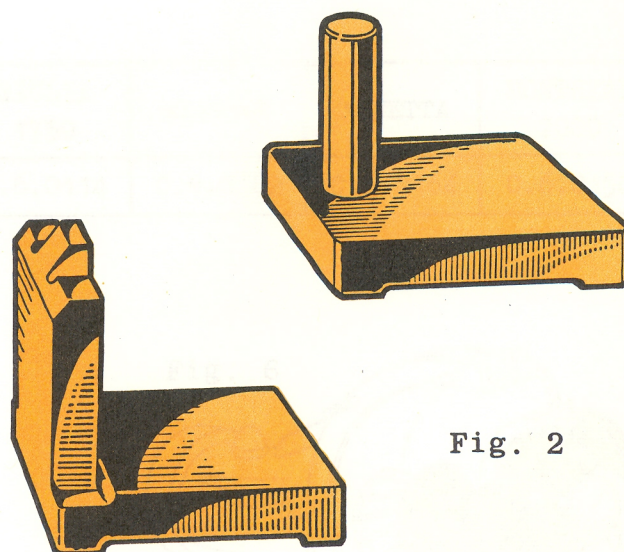

Fig. 2

2000	GIULIA 1750	ALFASUD	ALFETTA	MONTREAL
C.6.0170	C.6.0101	C.6.0161	C.6.0163 C.6.0166	C.6.0158

Deletes and supersedes T.B.  
No. 27/4 dated 18/6/1973

- 3 Fit the dummy shaft into the differential carrier bearing seat (see figg. 4 and 5) following strictly the procedure given in the Shop Manual.

The successful outcome of the entire checking procedure depends mainly on the perfect positioning of the dummy shaft.

Therefore, the tool and seat matching surfaces must be thoroughly cleaned.

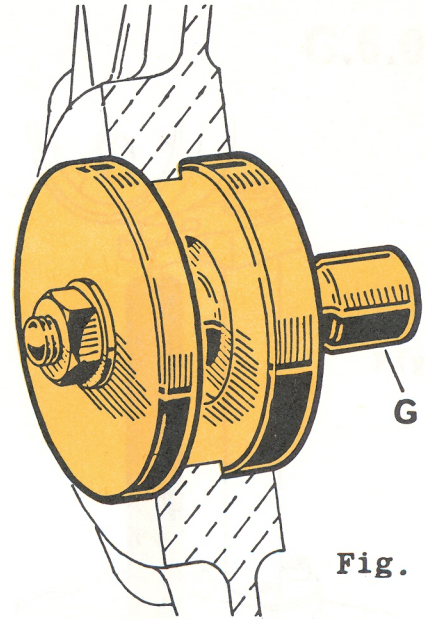

Fig. 4

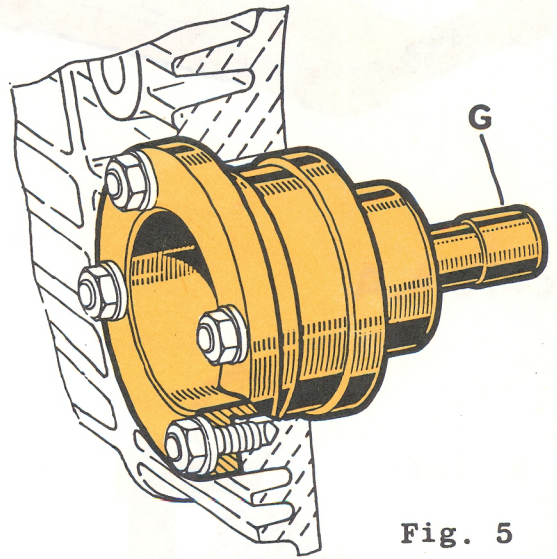

Fig. 5

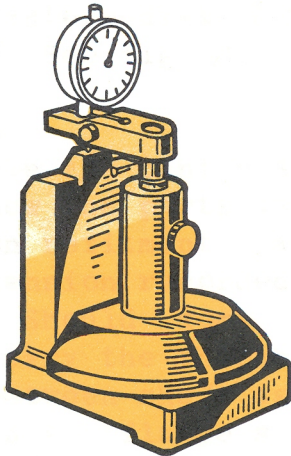

Fig. 3

GIULIA 1750	ALFASUD	ALFETTA	MONTREAL 2000
C.6.0114	C.6.0162	C.6.0164	C.6.0156

- 4 Place the dial gauge support in position as shown at fig. 6 and move it back and forth until the highest "lift" on the dummy shaft "G" is found.

Take readings and adjust accordingly as directed in the "Shop Manuals" and "Inspection Specifications".

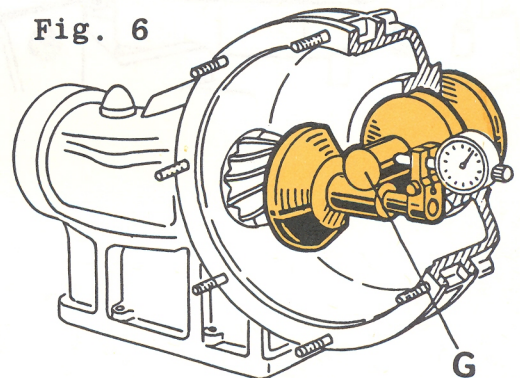

Fig. 6

DISMANTLING THE PINION SHAFT OF AL-FETTA MODEL

C.6.0166

5 If, on overhaul, the replacement of either some gears or the whole gearing is required, it is possible to refit all components with no need for checking the distance from pinion to ring gear centreline provided the directions outlined in paragraph 6, 7, 8 below are followed.

6 Install a dial gauge on the support A.4.0145 and set it to zero against the reference gauge C.6.0166. See fig. 7.

7 Before withdrawing gears from pinion shaft, record the reading of the intermediate flange-to-pinion end. See fig. 8.

8 Dismantle the pinion shaft assembly, renew the parts as required, and, on refitment, again check the dimension recorded as per 7 above. Should some difference exist, vary the thickness of the shims between shaft assembly and intermediate flange so as to restore the previously recorded dimension.

NOTE

For adjustment data refer to the "Shop Manual" and "Inspection Specifications".

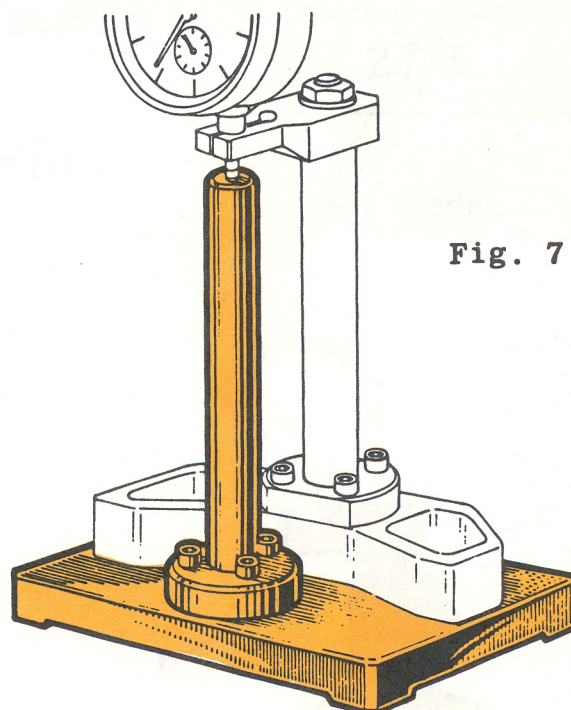

Fig. 7

A.4.0145

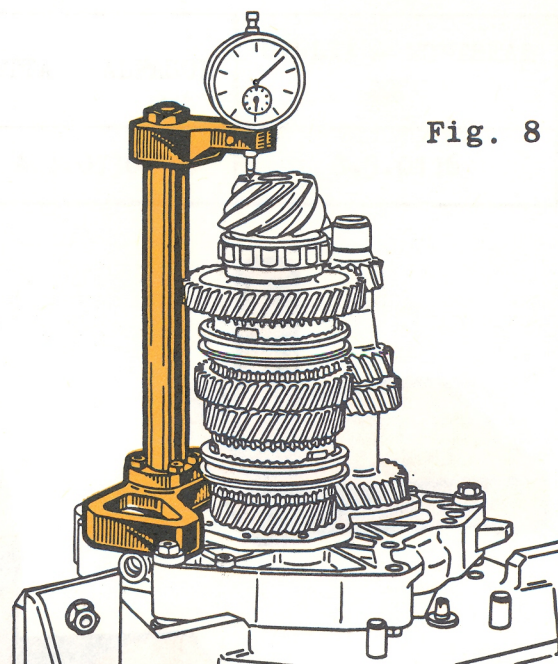

Fig. 8

GENERAL TOOLS

SPECIAL TOOLS

X

MACHINERY

EQUIPMENT

MISCELLANEOUS

# Alfa Romeo

DIREZIONE ASSISTENZA

DATE

30-4-1965

SEQUENT NUMBER

33/2

Giulietta - Giulia

2000-2600

## Tooling News

### WITHDRAWAL OF AXLE SHAFTS AND WHEEL HUBS WITHDRAWAL AND INSTALLATION OF AXLE SHAFT BEARINGS

#### WITHDRAWAL OF AXLE SHAFT (shoe brakes)

- ① Remove the four nuts "A".
- ② Pass offset pins "B" through holes into the axle shaft flange and tighten by hand the nuts "C" against the plate "T".
- ③ Mount the puller "D" as shown and withdraw the shaft by turning the screw "E".

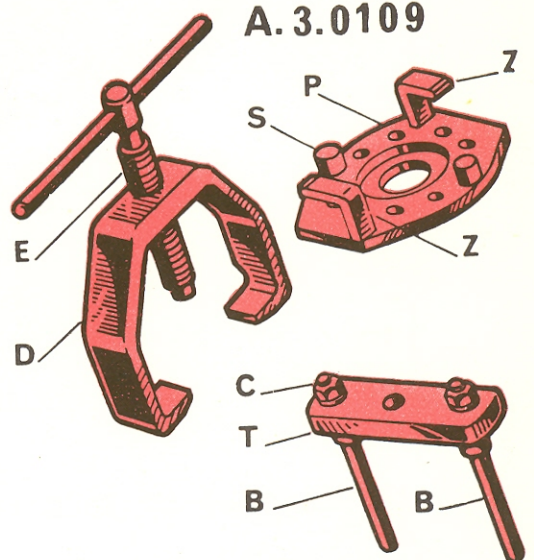
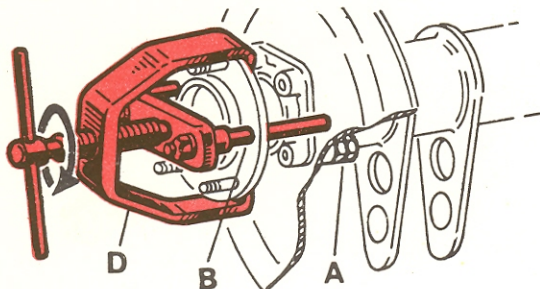

#### WITHDRAWAL OF AXLE SHAFT (disc brakes)

- ④ The same steps 1, 2 and 3 as for shoe brakes apply; for Giulia models only, install the tool A.3.0109/1 on the axle as shown.

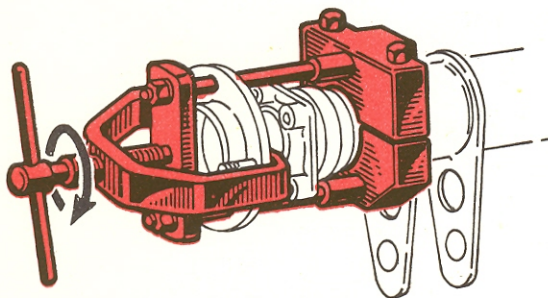

#### A. 3.0109/1

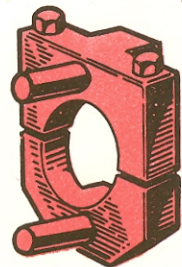

#### WITHDRAWAL OF WHEEL HUBS (shoe brakes)

- ① Mount the puller "D" onto the hub flange and, turning the screw "E" against the stub axle, withdraw the hub.

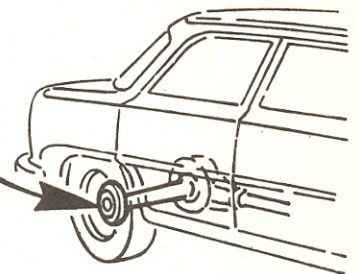
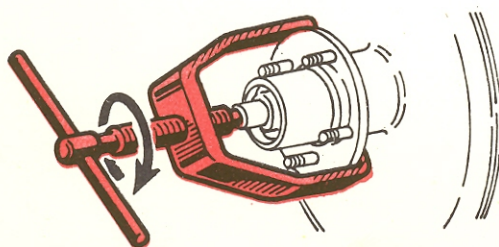

## WITHDRAWAL OF AXLE SHAFT BEARINGS (for both shoe and disc brakes)

- ① Mount the plate "P" on the shaft bearing housing and tighten the nuts.
- ② Pass the offset pins "B" through the holes into the shaft flange so that they rest against the bosses "S".
- ③ Mount the puller "D" onto the shaft flange making sure the screw "E" is perfectly centered and withdraw the shaft.

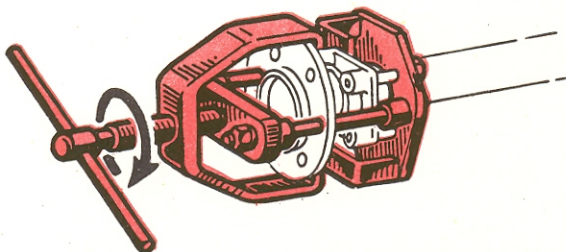

N.B. - The same procedure applies also to disc brakes, except that offset pins do not rest against bosses "S", but directly against the plate "P".

## INSTALLATION OF AXLE SHAFT BEARING (for both shoe and disc brakes)

- ① Mount the plate "P" on shaft bearing housing and tighten the nuts.
- ② Engage the puller "D" with the brackets "Z".  
The bearing can now be driven in place by turning the screw "E" against the end of the shaft as shown.  
Make sure the screw "E" is perfectly centered.

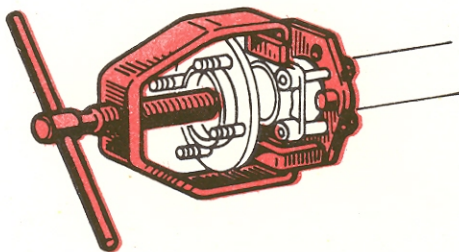

GENERAL TOOLS	X
SPECIAL TOOLS	
MACHINERY	
EQUIPMENT	
MISCELLANEOUS	

# Alfa Romeo

DIREZIONE ASSISTENZA

## Tool Bulletin

DATE

20-5-1964

SEQUENT NUMBER

34/1

**Giulietta - Giulia  
2000 - 2600**

### DISASSEMBLY OF STANDARDIZED GEARBOX LAYSHAFT

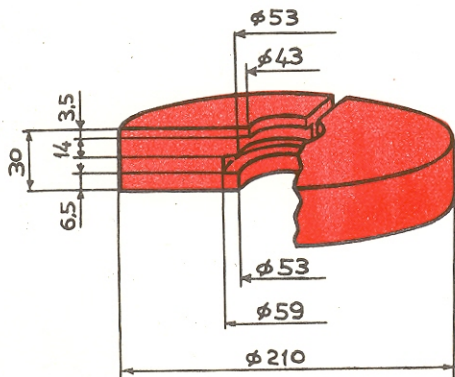

30 mm	= 1.18"
14 mm	= .55"
3,5 mm	= .14"
6,5 mm	= .25"
53 mm	= 2.09"
43 mm	= 1.69"
59 mm	= 2.32"
210 mm	= 8.27"

### HYDRAULIC PRESS

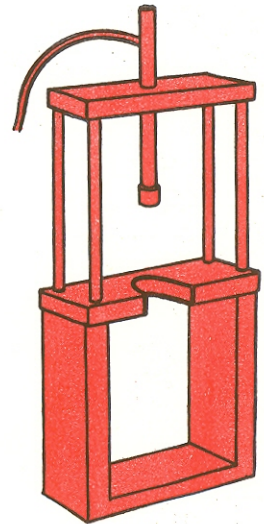

Use a press with a bed plate like that shown in the sketch (i.e. having a relief for the shafts). If not available, provide means suitable for this purpose.

**1** Locally manufacture the half-plates according to dimensions shown.

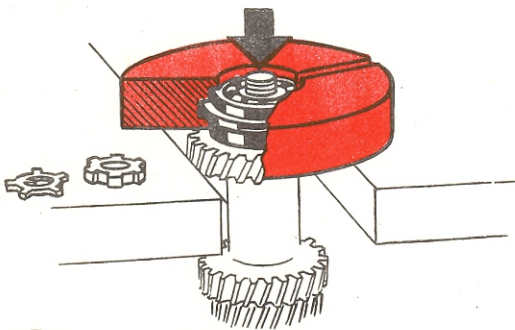

**2** Pulling the layshaft front bearing  
Remove tabwasher and ringnut; properly place the half-plates around the bearing and press it off.

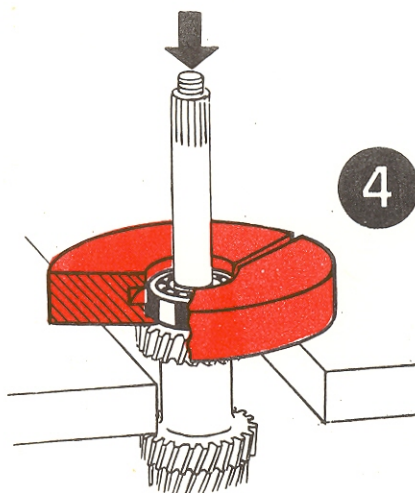

**4** Pulling the intermediate bearing (5-speed gearbox)

Remove tabwasher, ringnut, roller bearing, keying sleeve and 5th & reverse gear unit. With the half-plates press the bearing off.

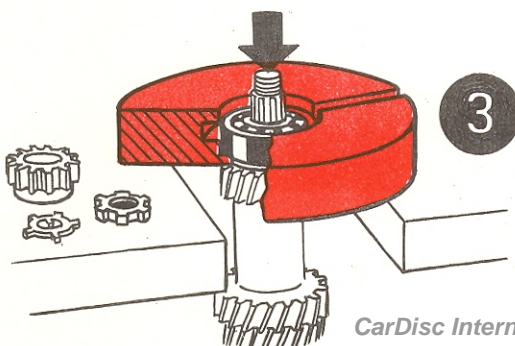

**3** Pulling the layshaft rear bearing (4-speed gearbox)

Remove tabwasher, ringnut and reverse pinion; properly place the half-plates around the bearing and press it off.

GENERAL TOOLS

SPECIAL TOOLS

X

MACHINERY

EQUIPMENT

MISCELLANEOUS

# Alfa Romeo

DIREZIONE ASSISTENZA

DATE  
10-4-1962

SEQUENT NUMBER

35/1

1600  
GIULIETTA

## Tool Bulletin

### A.3.0115

#### WITHDRAWAL OF BEARING CUPS FROM DIFFERENTIAL CARRIER

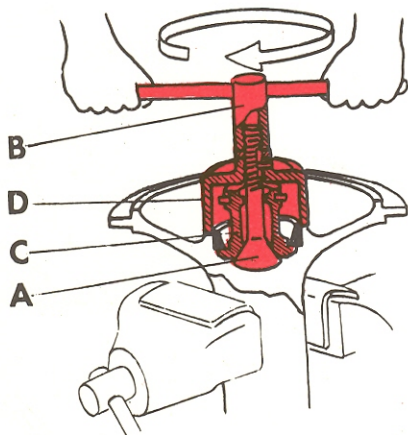

1

Place the differential carrier or the axle tube so that the bearing  $\phi$  line is vertical.

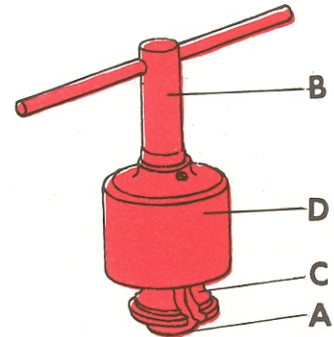

2

Fully unscrew the wedge "A" out of the handle "B"; install the tool in such a way as to engage the jaws "C" firmly against the bearing cup; then withdraw the cup.

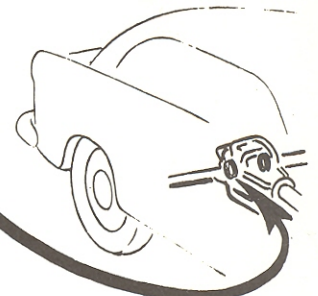
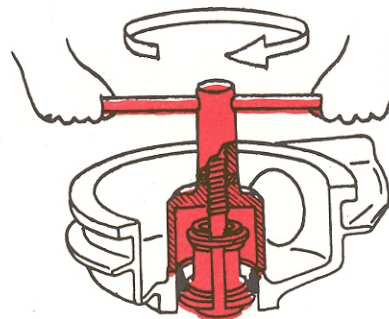

GENERAL TOOLS	
SPECIAL TOOLS	X
MACHINERY	
EQUIPMENT	
MISCELLANEOUS	

# Alfa Romeo

DIREZIONE ASSISTENZA CLIENTI

DATE

31-12-1971

SEQUENT NUMBER

35/2

## Tooling News

Giulia - 1750  
2000 - Montreal

### A.3.0115

## WITHDRAWAL OF DIFFERENTIAL BEARING CUPS

### WITHDRAWING THE CUP FROM L.H. TUBE

- 1 Clamp the L.H. axle tube upright in a vise.
- 2 Unscrew the sleeve "A" so that jaws "B" get close together.
- 3 Install the tool as shown in fig.1 making certain the jaws "B" properly engage the cup to be withdrawn.
- 4 Turn the handle "C" to withdraw the cup.

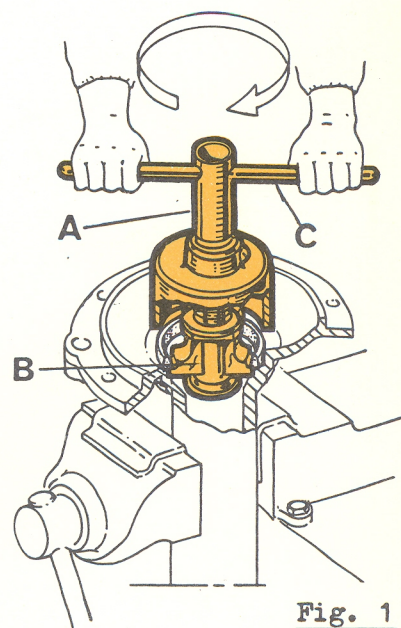
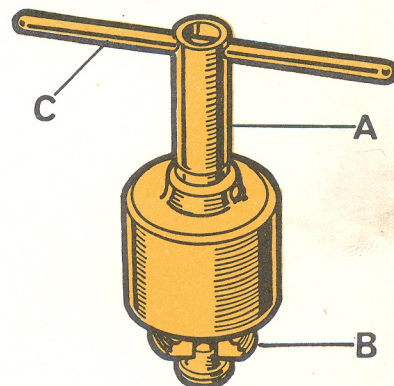

### WITHDRAWING THE CUP FROM CARRIER

- 5 Leave the carrier mounted on the suitable support
- 6 Withdraw the cup by proceeding as per 2, 3 and 4 above.

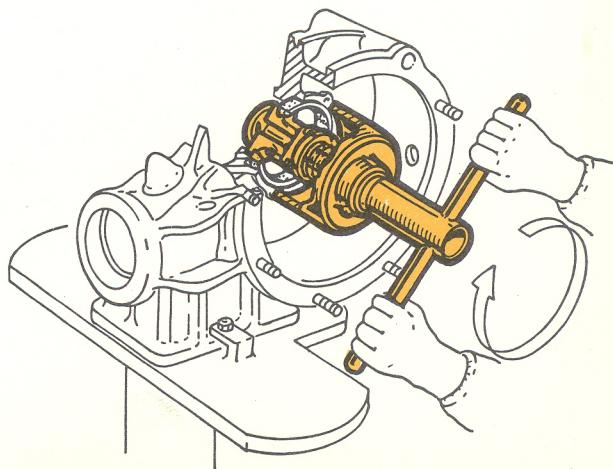

GENERAL TOOLS

SPECIAL TOOLS

MACHINERY

EQUIPMENT

MISCELLANEOUS

X

# Alfa Romeo

DIREZIONE ASSISTENZA CLIENTI

DATE

10-10-1960

SEQUENT NUMBER

38

GIULIA - 2000

mille Giulietta

ROMEO 2000

## Tooling News

### CENTERING OF DRIVEN CLUTCH PLATE DURING MOUNTING ON FLYWHEEL

1

Place the complete clutch in position and partly tighten the screws marked "A".

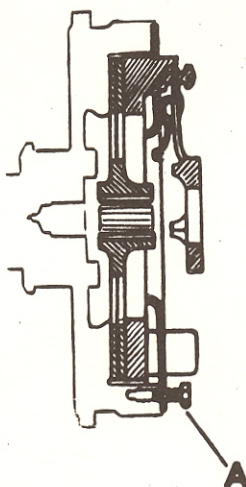

2

Insert the appropriate plug-gauge, centering the driven plate "B".

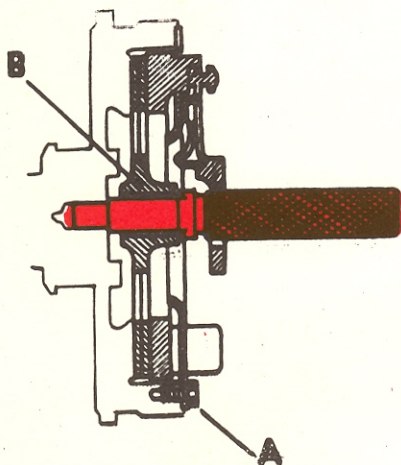

3

Tighten the screws marked "A" and remove the plug-gauge.

### A.4.0101

mille

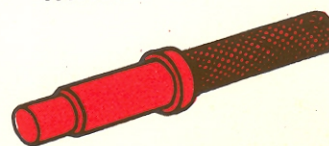

### A.4.0102

ROMEO



### A.4.0103

Giulietta  
GIULIA

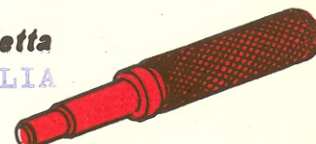

### A.4.0106

2000  
2600

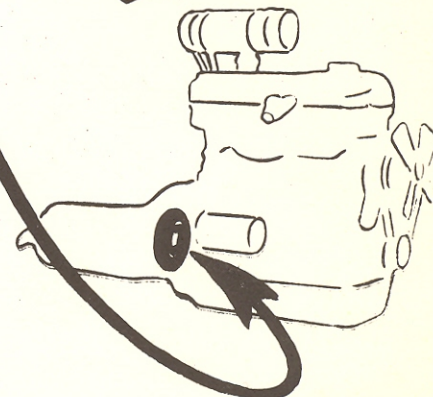
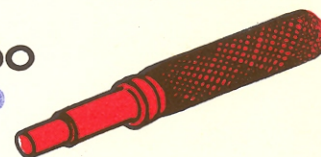

Translated in February 1963

GENERAL TOOLS	
SPECIAL TOOLS	<b>X</b>
MACHINERY	
EQUIPMENT	
MISCELLANEOUS	

# Alfa Romeo

DIREZIONE ASSISTENZA

DATE

20-5-1964

SEQUENT NUMBER

38/1

**Giulietta - Giulia  
2000 - 2600  
Romeo - Mille**

## Tool Bulletin

### CENTERING THE CLUTCH DRIVEN PLATE DURING THE ASSEMBLY ON THE FLYWHEEL

- 1 Install the clutch assembly by tightening the screws "A" only loose.

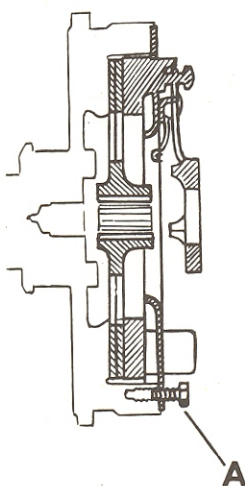

- 2 Insert the tool of the type as applicable and center the driven plate "B".

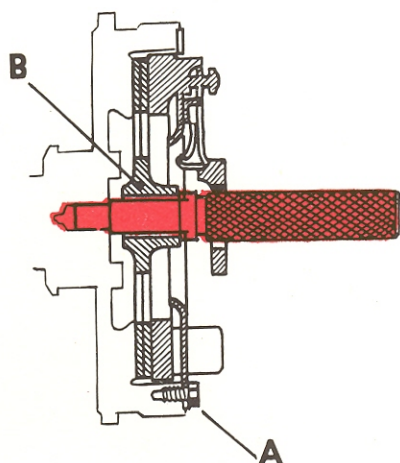

- 3 Lock the screws "A" and withdraw the tool.

**A.4.0101**

Mille

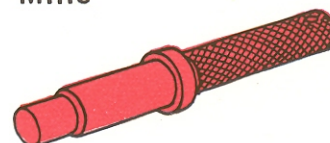

**A.4.0102**

Romeo



**A.4.0103**

Giulietta - Giulia

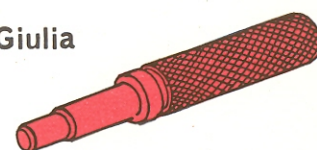

**A.4.0106**

2000 - 2600

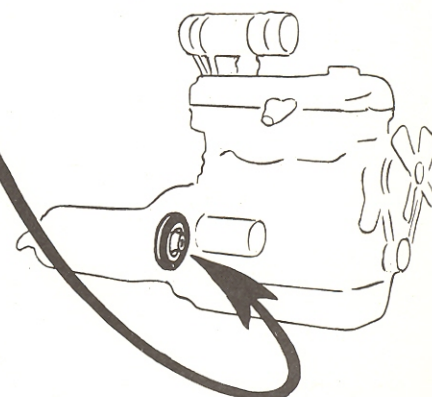
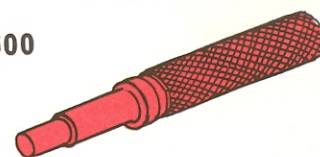

This Bulletin deletes and supersedes T.N. no 38 dated 10/10/960

GENERAL TOOLS	
SPECIAL TOOLS	X
MACHINERY	
EQUIPMENT	
MISCELLANEOUS	

# Alfa Romeo

DIREZIONE ASSISTENZA

## Tool Bulletin

DATE

31-12-1971

SEQUENT NUMBER

38/2

Giulia - 1750  
2000 - Montreal

F 12

**A.4.0103**

Giulia - 1750 - 2000 - F 12

**A.4.0133**

Montreal

### CENTRING THE DRIVEN PLATE WHILE FITTING THE CLUTCH TO THE FLYWHEEL

**1** Mount the clutch assembly on the flywheel; screw in the screws "A" to such an extent that the driven plate is not locked.

**2** Insert the spindle "C" as applicable. Make sure the dowel at the end of the spindle enters properly the bushing "D" in the crankshaft otherwise the driven plate would not be perfectly centred.

**3** Securely tighten the screws "A" and withdraw the spindle.

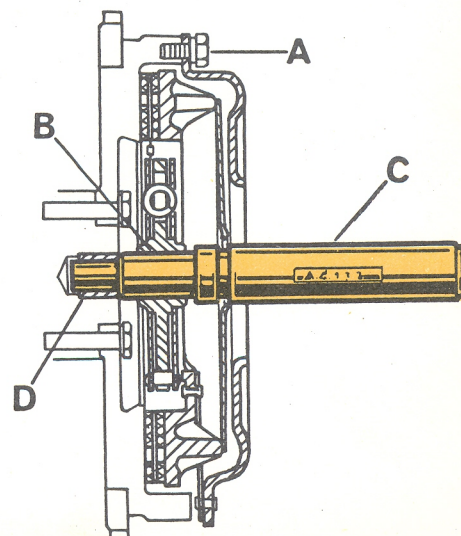
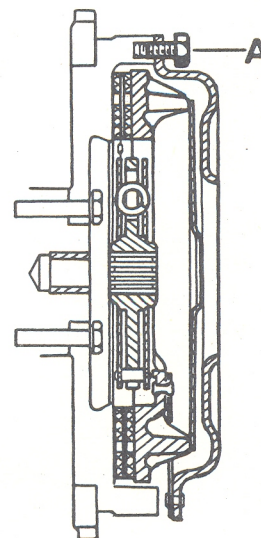
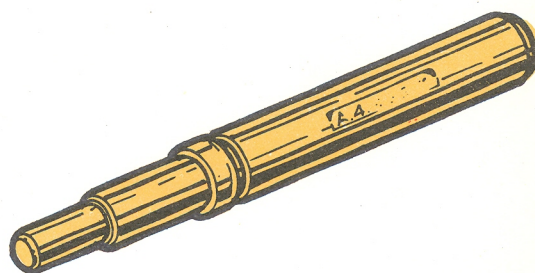

This Bulletin deletes and supersedes the T.B. no. 38/1 dated 20/5/1964

GENERAL TOOLS

SPECIAL TOOLS

X

MACHINERY

EQUIPMENT

MISCELLANEOUS

# Alfa Romeo

## DIREZIONE ASSISTENZA CLIENTI

DATE

10-10-1960

SEQUENT NUMBER

40 ✓

GIULIA - 2600  
Giulietta  
2000

### Tooling News

#### REMOVAL AND INSERTION OF OUTER BEARING RACES ON FRONT WHEEL HUBS

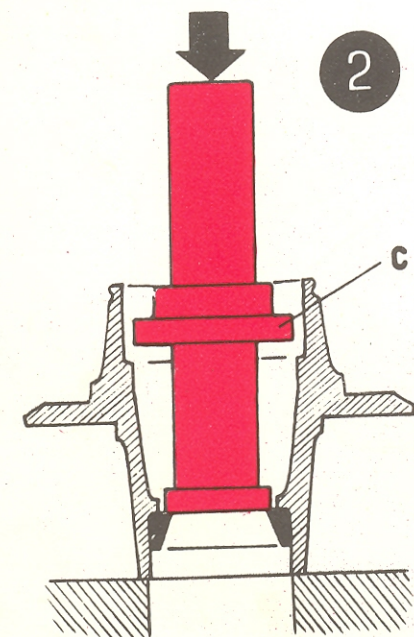
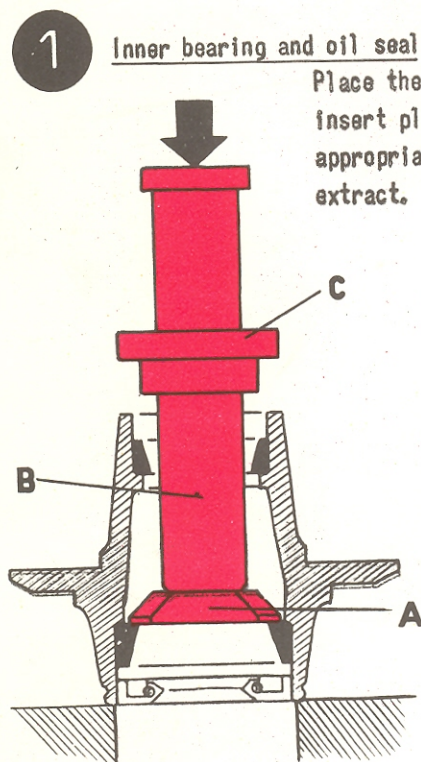

N.B. - When inserting the races proceed as above, utilising the different sized rings "C" on the tool.

**A3.0120**  
Giulietta GIULIA

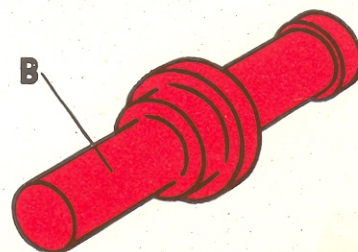

**A3.0121**  
2000 2600

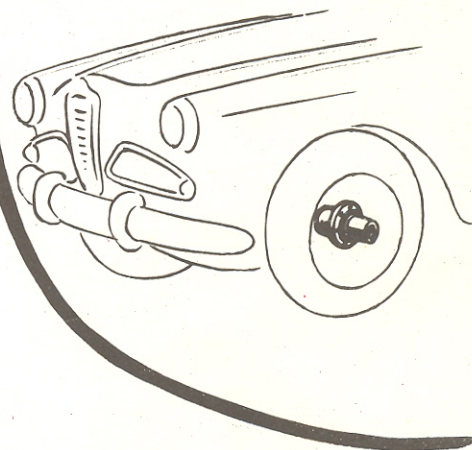

GENERAL TOOLS	
SPECIAL TOOLS	X
MACHINERY	
EQUIPMENT	
MISCELLANEOUS	

# Alfa Romeo

DIREZIONE ASSISTENZA CLIENTI

DATE  
28-12-1971

SEQUENT NUMBER  
40/2

2600 - Giulia  
1750 - 2000  
Montreal

## Tooling News

### A.3.0120

(Giulia - 1750  
2000 - Montreal)

### A.3.0121

(2600)

## WITHDRAWING AND DRIVING OF FRONT WHEEL BEARING CUPS

Withdrawing the inboard bearing cup (fig. 1)

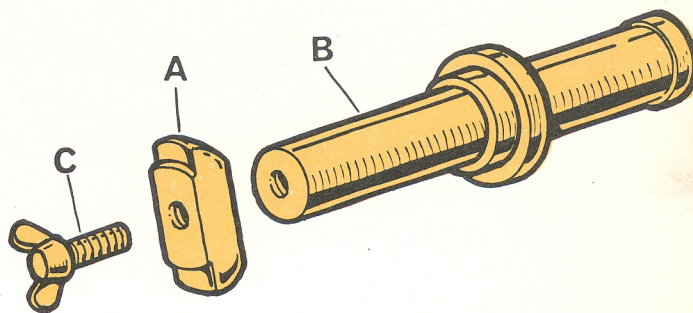

1 Place the hub on a press.

2 Mount the adapter "A" on the shaft "B" and rest the tool so assembled against the cup to be withdrawn.

3 Withdraw the cup by acting with the press on the shaft "B".

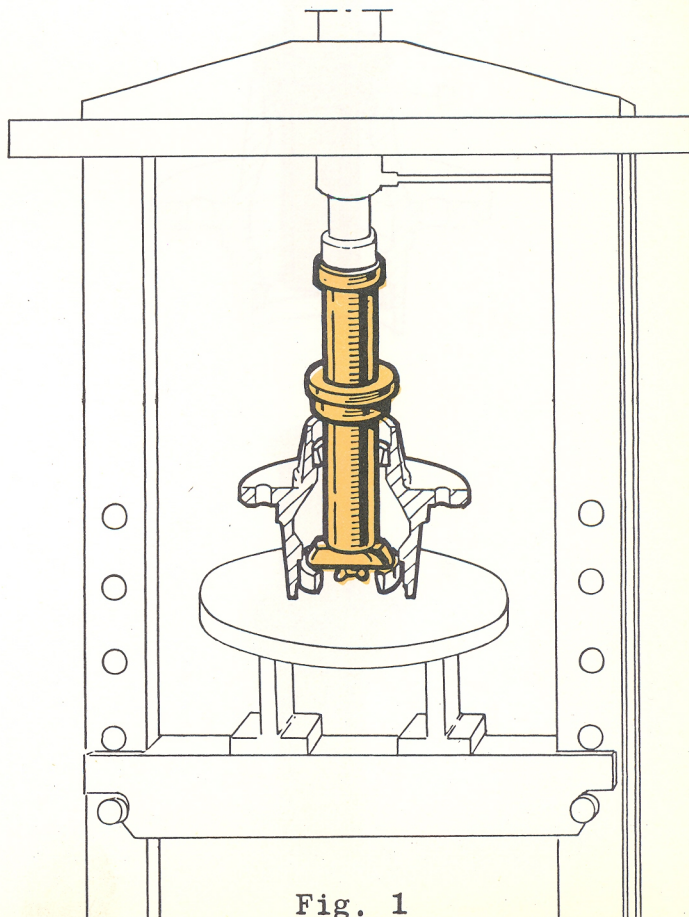

Fig. 1

This Bulletin deletes and supersedes the T.B. no. 40/1 dated 20/5/1964

Withdrawing the outboard bearing cup (fig. 2)

- 4 Place the hub on the press upside down with respect to fig. 1.
- 5 Turn over even the shaft and rest it against the cup to be withdrawn.
- 6 Withdraw the cup as outlined in 3 above.

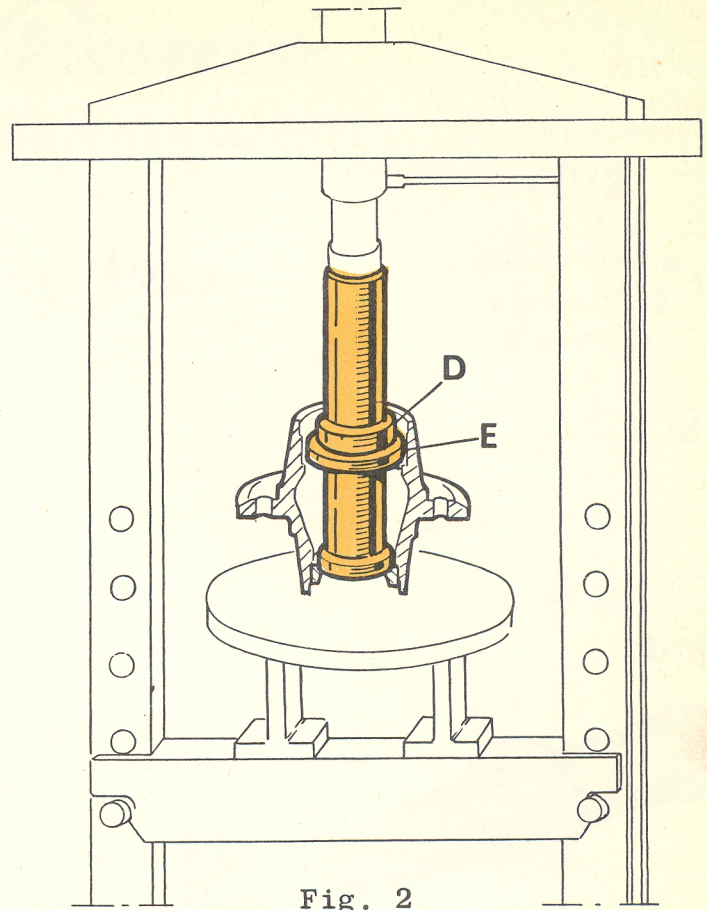

Fig. 2

Driving the outboard bearing cup (fig. 3)

- 7 Place the hub on the press.
- 8 Place the cup in its seat.
- 9 Insert the shaft "A" so that the abutment "D" fits the cup.
- 10 Drive the cup into the seat by operating the press.
- 11 Release the press and pull out the shaft.

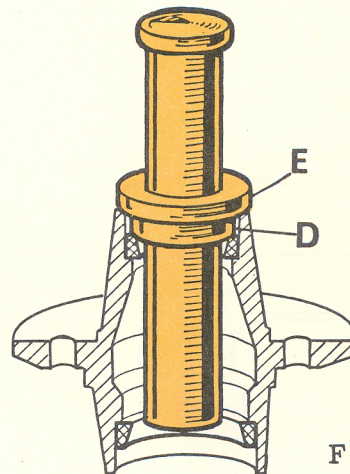

Fig. 3

Driving the inboard bearing cup (fig. 4)

- 12 Proceed the same way as outlined by steps 7 thru 11 using, however, the abutment "E".

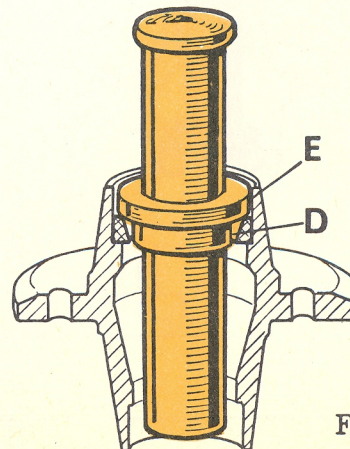

Fig. 4

GENERAL TOOLS	
SPECIAL TOOLS	X
MACHINERY	
EQUIPMENT	
MISCELLANEOUS	

# Alfa Romeo

DIREZIONE ASSISTENZA CLIENTI

DATE

22-3-1965

SEQUENT NUMBER

41/1

## Tooling News

### Giulietta

### A3.0107

#### INSTALLATION OR WITHDRAWAL OF MAINSHAFT AND LAYSHAFT OF OLD STYLE GEARBOX

1. Mount the gearbox on the rig.

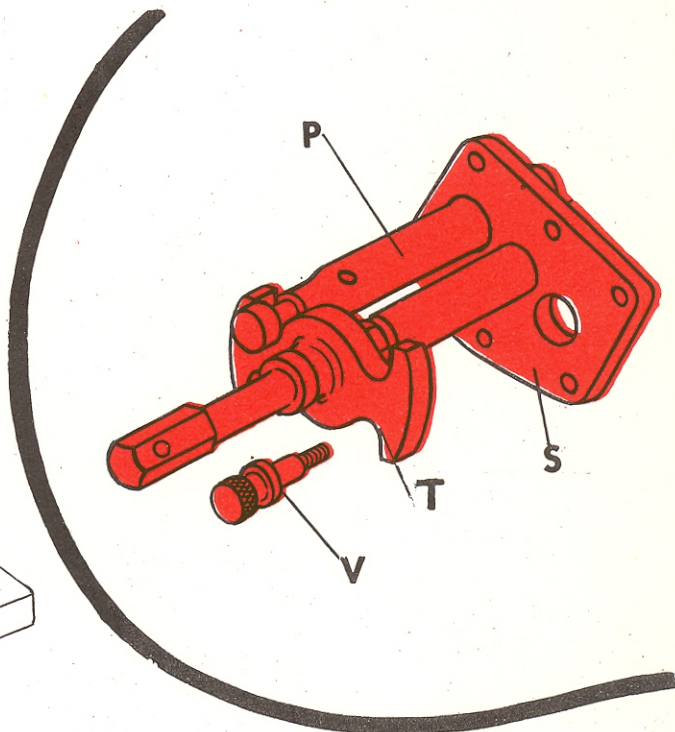
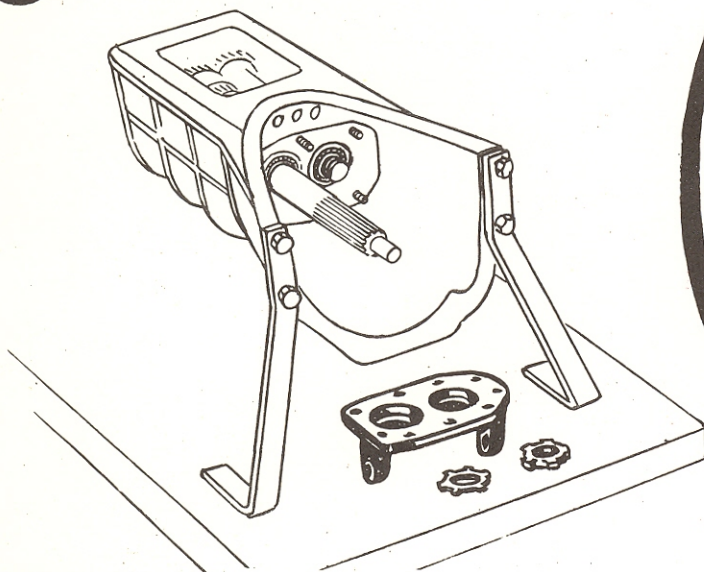

2. Remove the front cover, the retainer ring of mainshaft bearing and the ringnut of layshaft bearing.

5. Place the bracket "T" in proper position according to direction of rotation of main screw (withdrawal or installation)

3. Fix the flange "S" with four nuts.

6. Turn the main screw with a 27 mm (1 - 1/16") hex. wrench.

4. Screw the extension "P" onto the layshaft threaded end and the screw "V" into the mainshaft.

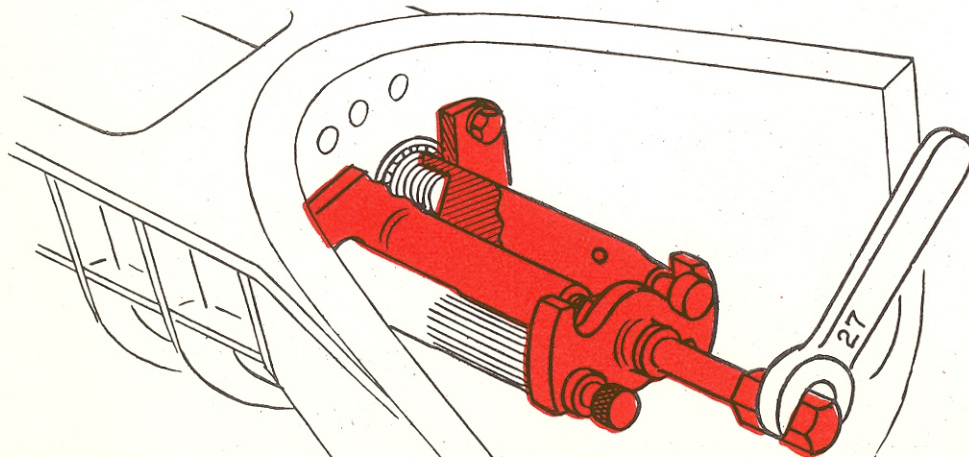

This T.N. deletes and supercedes no. 41 dated 14/3/1961

GENERAL TOOLS

SPECIAL TOOLS

X

MACHINERY

EQUIPMENT

MISCELLANEOUS

# Alfa Romeo

## DIREZIONE ASSISTENZA CLIENTI

DATE

3-5-1961

SEQUENT NUMBER

43 ✓

GIULIA - 2600

Giulietta  
2000

### Tooling News

#### REMOVAL OF FRONT WHEEL HUB COVERS

A.3.0124 <sup>GIULIA</sup> (Giulietta)

A.3.0127 (2000)

2600

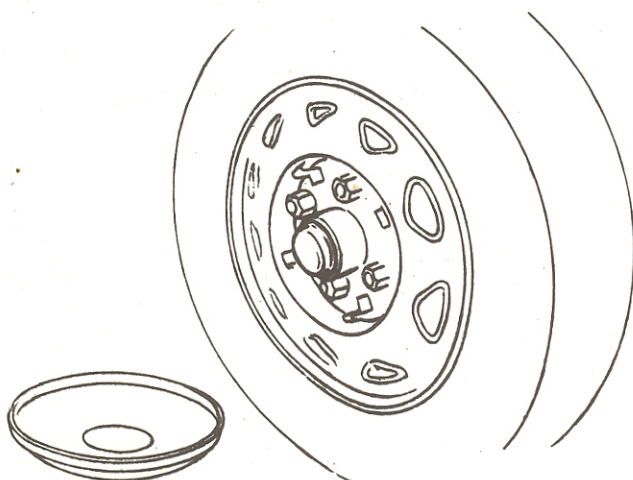

1 Remove the wheel disc.

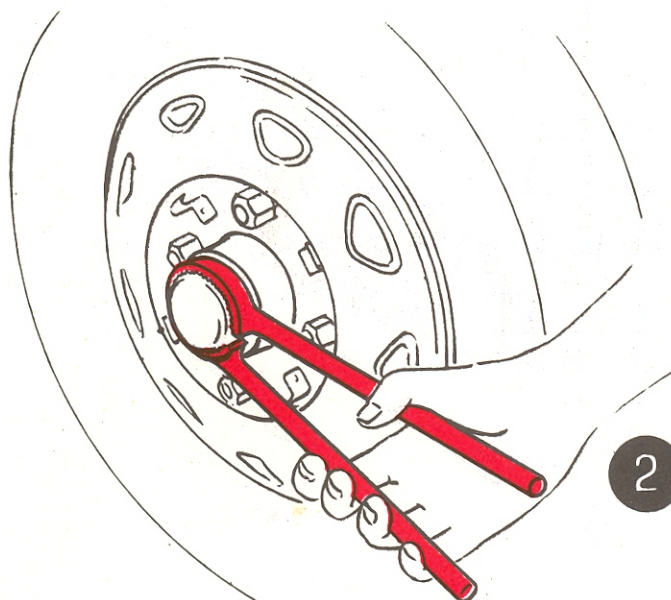

2 Fit the tool over the cover and, by pressing lightly on the grips, turn and remove the cover.

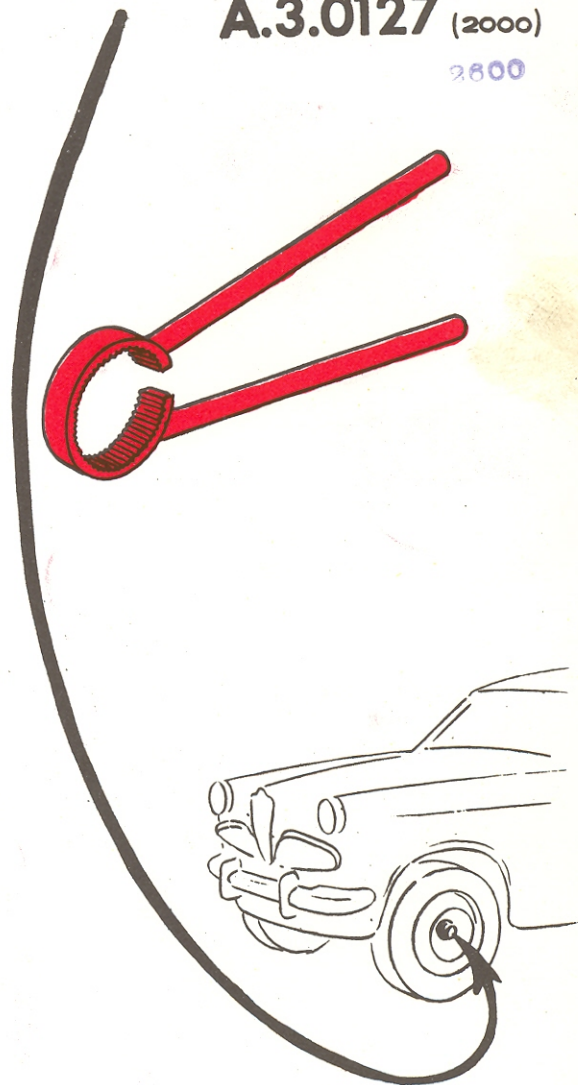

GENERAL TOOLS

SPECIAL TOOLS

X

MACHINERY

EQUIPMENT

MISCELLANEOUS

# Alfa Romeo

DIREZIONE ASSISTENZA

DATE

25/3/1965

SEQUENT NUMBER

43/2

## Tool Bulletin

Giulietta - Giulia  
2000-2600

### INSTALLATION AND WITHDRAWAL OF FRONT WHEEL HUB CAP

- 1 Remove the wheel cover.

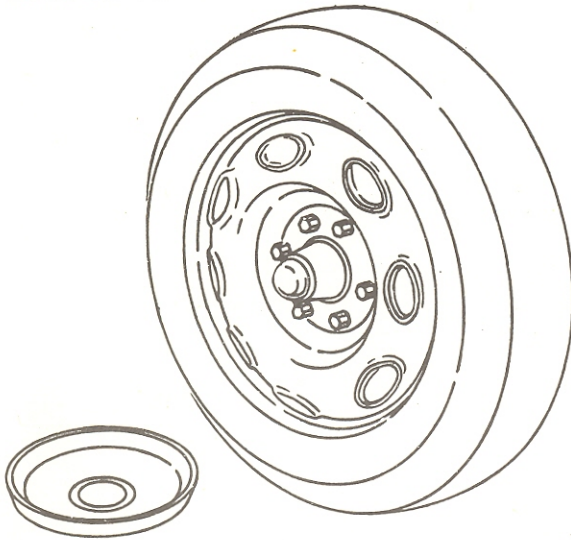

- 2 Fit the special tool with the aid of a mallet making sure that larger dia. bore in the clamp "A" is facing the wheel.

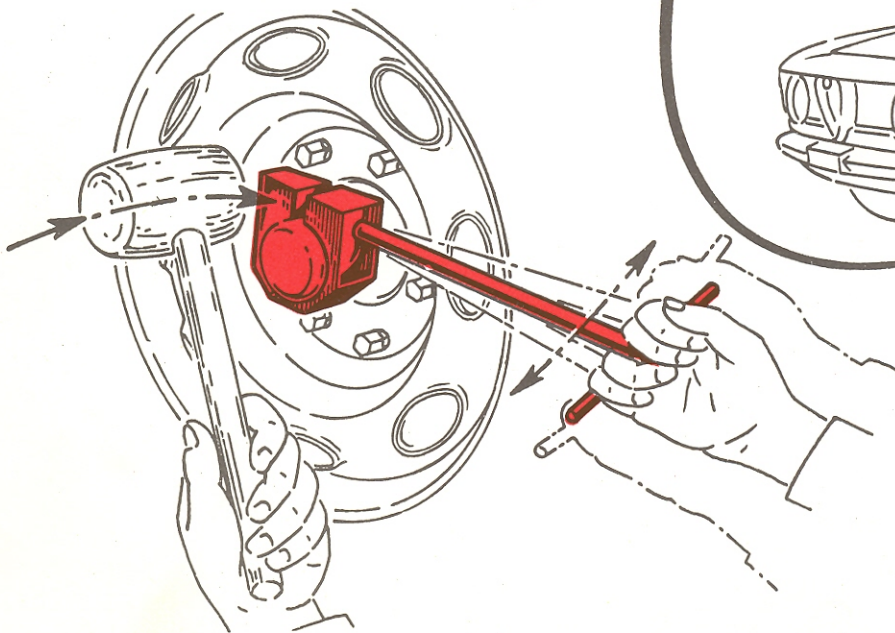

A.3.0124

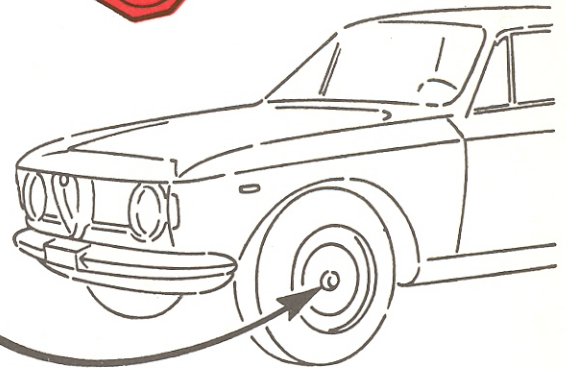
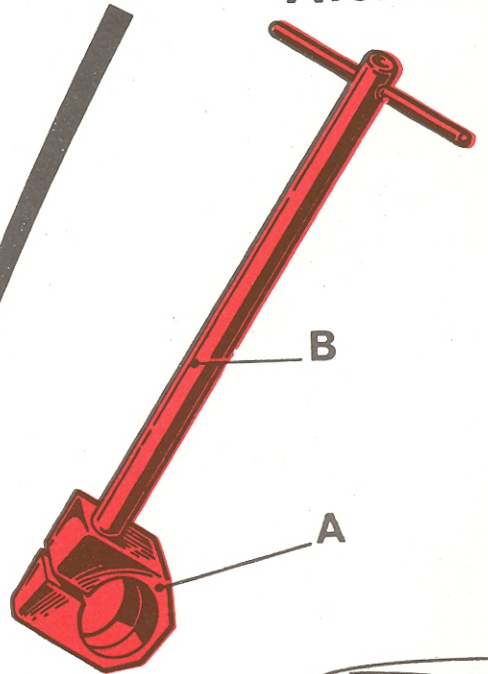

- 3 Tighten the clamp "A" around the hub cup by rotating the handle "B" and withdraw the cap.

- 4 To re-install the cap, tap with the mallet on the clamp "A".

This Bulletin deletes and super-  
sedes T.N. n° 43/1 dated 20/5/64

GENERAL TOOLS

SPECIAL TOOLS

X

MACHINERY

EQUIPMENT

MISCELLANEOUS

# Alfa Romeo

## DIREZIONE ASSISTENZA CLIENTI

### Tooling News

DATE

31 - 7 - 1961

SEQUENT NUMBER

46

GIULIA - 2600

Giulietta

2000

### REMOVAL AND FITTING OF GEARBOX SILENTBLOC ON THE BENCH

## A.3.0118

1

For the Giulietta gearbox, slide the unit consisting of the elements "A", "B", "C" and "D" into the hole through the silentbloc and fit the retaining plate "E" into the slot on "A", as shown in the sketch.

2

Turn nut "B" with a 24 mm spanner and extract. Ensure that the retaining plate "E" is accurately centred in relation to the external diameter of the silentbloc.

3

To insert the silentbloc, fit the retaining plate "E" into the end slot on "A" and turn nut "B".

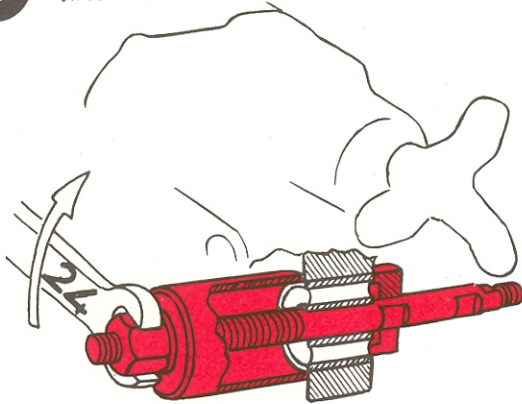

4

To extract the silentblochs of the 2000 gearbox, remove the grub screws and use elements "F" and "E" instead of "D" and "E".

5

The extension piece "H" must be fitted to insert the silentblochs of the 2000 gearbox.

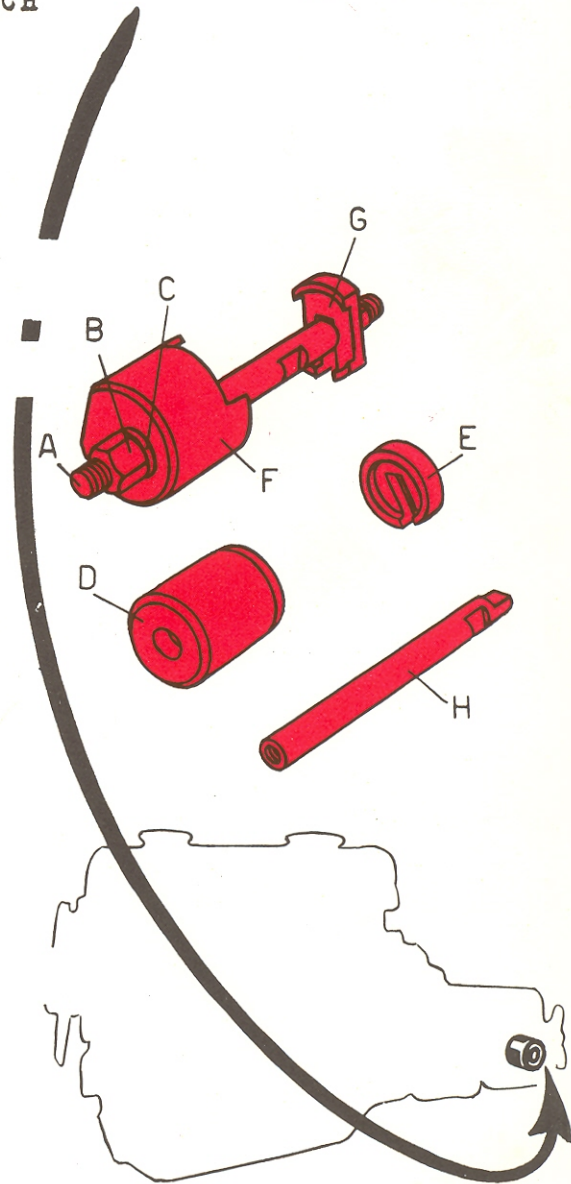
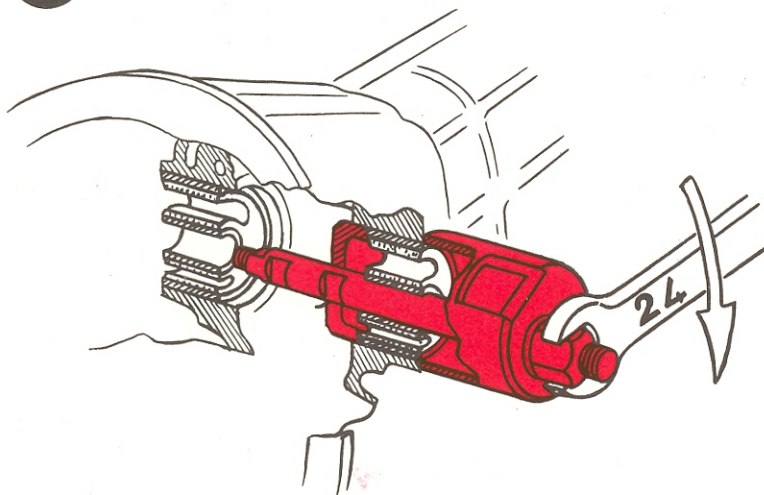

N.B. - The tool can be used directly on the car if necessary.

GENERAL TOOLS	
SPECIAL TOOLS	<b>X</b>
MACHINERY	
EQUIPMENT	
MISCELLANEOUS	

## Tool Bulletin

### REMOVAL AND FITTING OF GEARBOX RUBBER BUSHING ON THE BENCH

**A.3.0118**

- 1** For the Giulietta and Giulia gearbox, slide the unit consisting of the elements "A", "B", "C" and "D" into the hole through the rubber bushing and fit the retaining plate "E" into the slot on "A", as shown in the sketch.
- 2** Turn nut "B" with a 24 mm spanner and extract. Ensure that the retaining plate "E" is accurately centred in relation to the external diameter of the rubber bushing.
- 3** To insert the rubber bushing, fit the retaining plate "E" in to the end slot on "A" and turn nut "B".

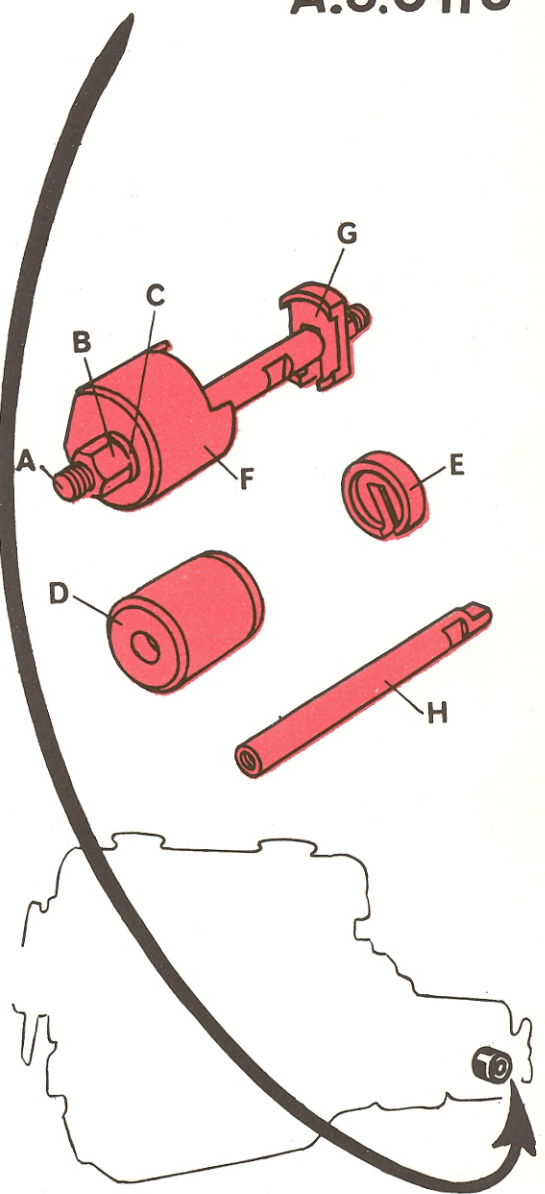
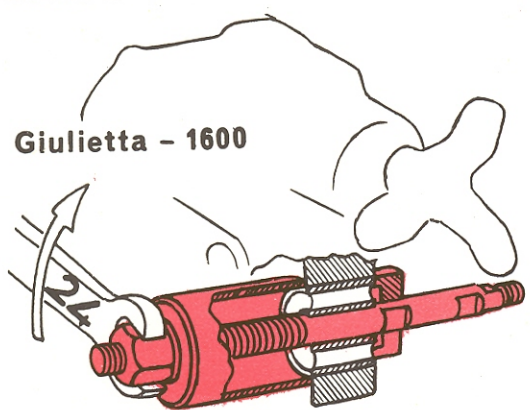

- 4** To extract the rubber bushings of the 2000 and 2600 gearbox, remove the grub screws and use elements "F" and "G" instead of "D" and "E".
- 5** The extension piece "H" must be fitted to insert the rubber bushings of the 2000 and 2600 gearbox.

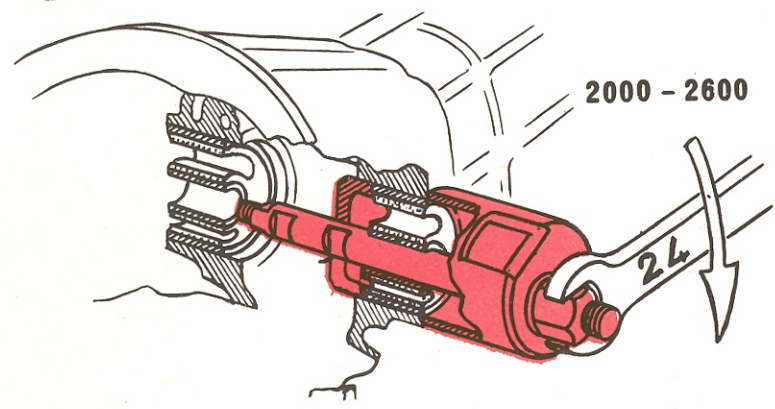

N.B. - The tool can be used directly on the car, if necessary.

GENERAL TOOLS	
SPECIAL TOOLS	X
MACHINERY	
EQUIPMENT	
MISCELLANEOUS	

## Tool Bulletin

### REMOVAL AND REFITMENT OF GEARBOX RUBBER BUSHING

A.3.0118

#### REMOVAL

- 1 After having taken the gearbox off the mounting bracket, fit the tool components "A", "B" and "C" to the rubber bushing. Position the plate "D" in the "Removal" groove; see illustration.
- 2 With a 24 mm spanner turn the nut "C" to withdraw the rubber bushing. Make sure the plate "D" is well centred on the rubber bushing outside barrel.

#### REFITMENT

- 3 Position the plate "D" in the "Refitment" groove shown in the illustration and refit the rubber bushing.

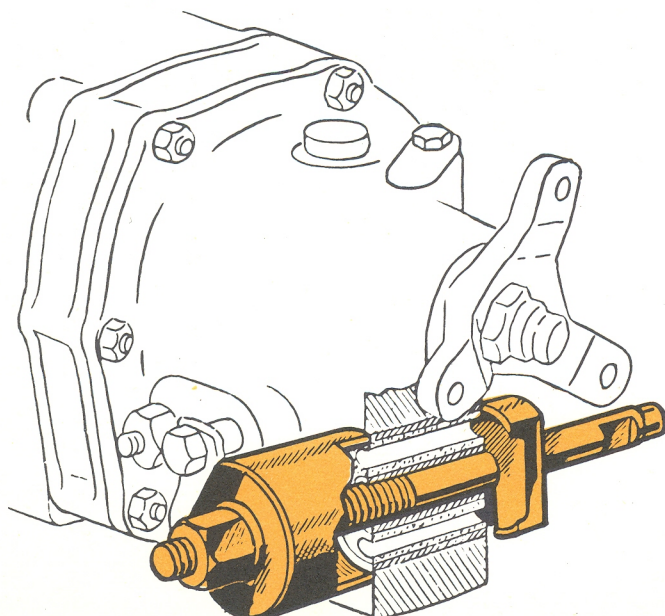
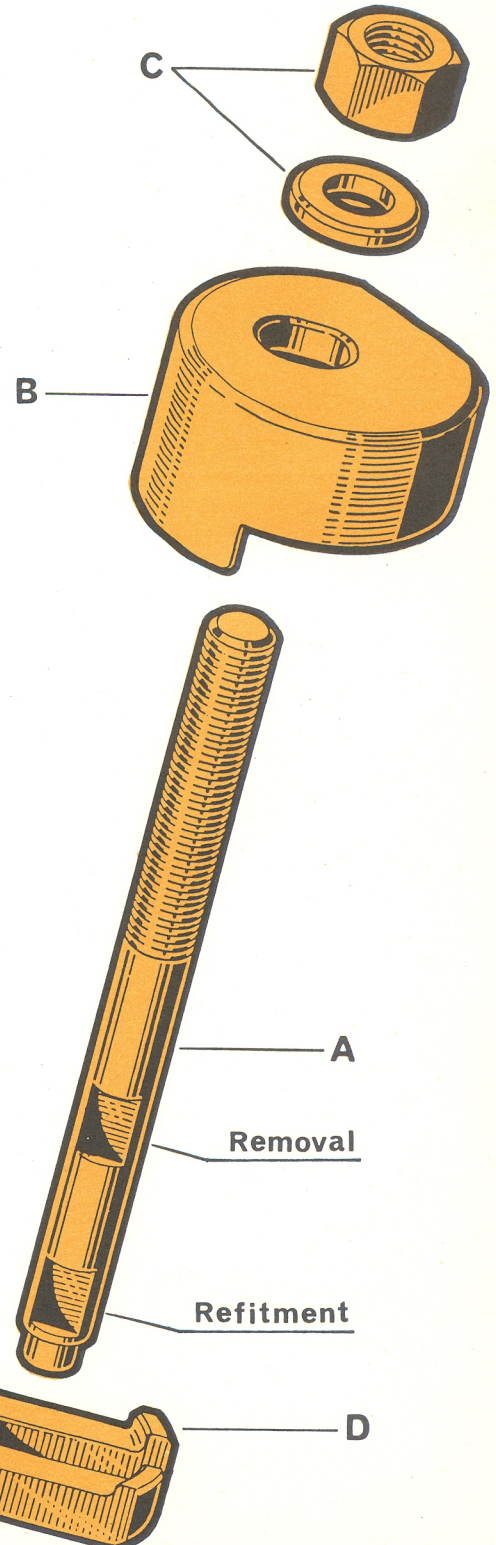

GENERAL TOOLS	
SPECIAL TOOLS	X
MACHINERY	
EQUIPMENT	
MISCELLANEOUS	

# Alfa Romeo

DIREZIONE ASSISTENZA

DATE

20-5-1964

SEQUENT NUMBER

47/2

**Giulietta - Giulia**  
**2600**

## Tool Bulletin

### DRIVING THE OIL PASSAGE PLUGS INTO THE CRANKCASE

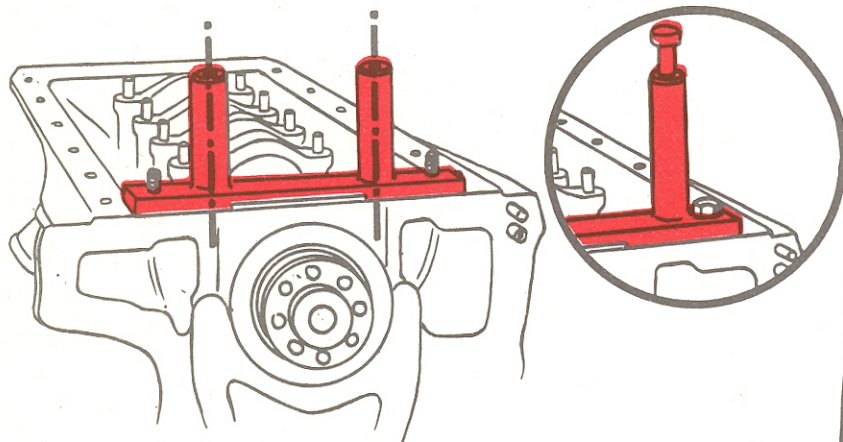

**A.3.0113**  
(Giulietta)  
(Giulia)

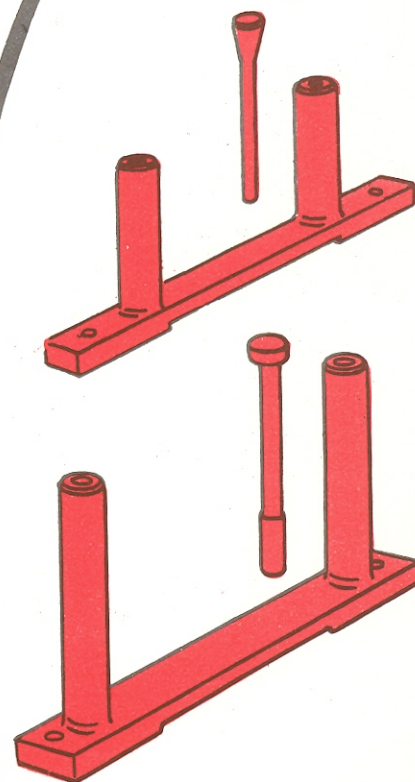

**A.3.0145**  
(2600)

**1** Mount the tool on crankcase and secure with two studs (Giulietta-Giulia) or with two drive screws. (2600)

**2** Coat the plugs "B" with grease and insert them in the guides.

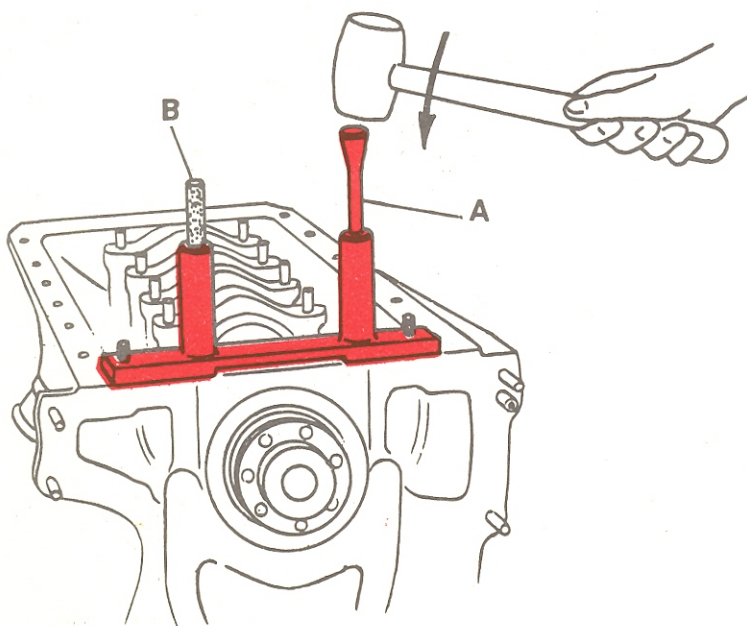

**3** With a mallet and the punch "A" carefully drive the plugs into the crankcase until the grease appears at the edge of the bores in crankcase.

GENERAL TOOLS	
SPECIAL TOOLS	X
MACHINERY	
EQUIPMENT	
MISCELLANEOUS	

# Alfa Romeo

DIREZIONE ASSISTENZA

## Tool Bulletin

DATE

26-2-1973

SEQUENT NUMBER

47/4

Giulia - 1750  
2000 - Alfetta  
F 12

### A.3.0113

## DRIVING THE OIL PASSAGE SEALS INTO THE CRANKCASE

- 1 Mount the tool on crankcase and secure with two screws of proper diameter and thread.
- 2 Make sure that guides and seal bores in crankcase are aligned.
- 3 Coat the seals "B" with grease and insert them in the guides.
- 4 With a mallet and the punch "A" carefully drive the seals into the crankcase until the grease appears at the edge of the bores in crankcase.

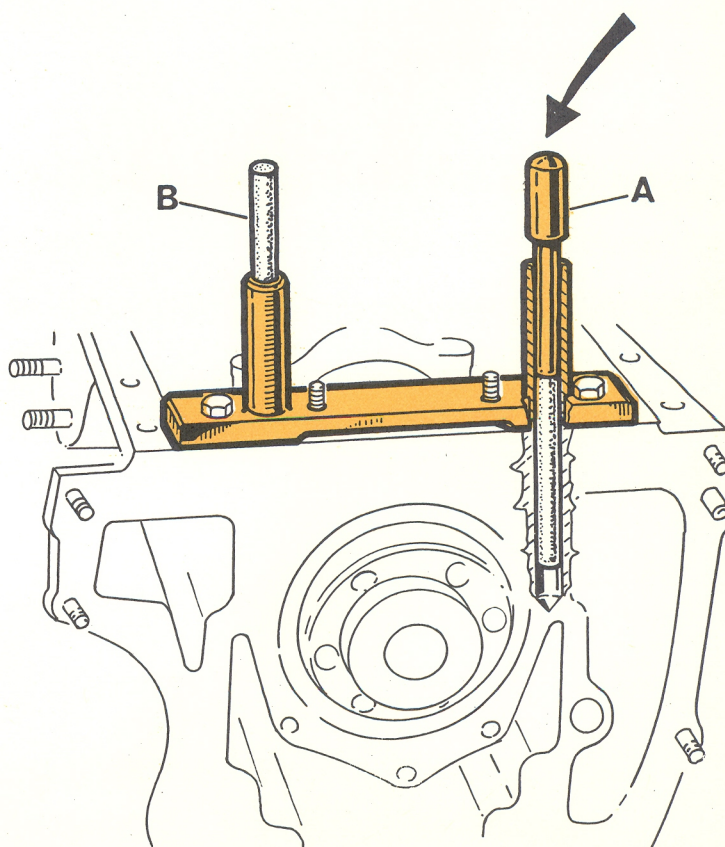
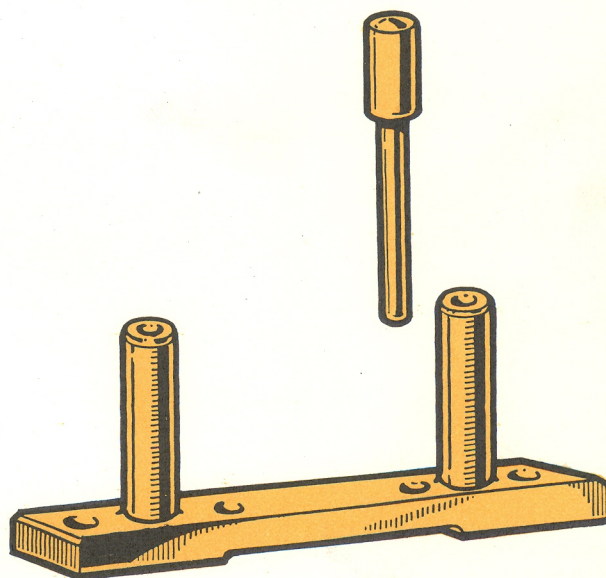

Deletes and supersedes T.B.  
No. 47/3 dated 11/4/1972

GENERAL TOOLS	
SPECIAL TOOLS	X
MACHINERY	
EQUIPMENT	
MISCELLANEOUS	

# Alfa Romeo

DIREZIONE ASSISTENZA CLIENTI

DATE  
5-5-1961

SEQUENT NUMBER  
51

GIULIA - 2600  
Giulietta  
2000

## Tooling News

**C.5.0111**

### SELECTION OF VALVE-CLEARANCE ADJUSTMENT CAPS

- 1 Set the tool up on dial indicator stand 6123.41.111 and secure by means of the two screws marked "A".

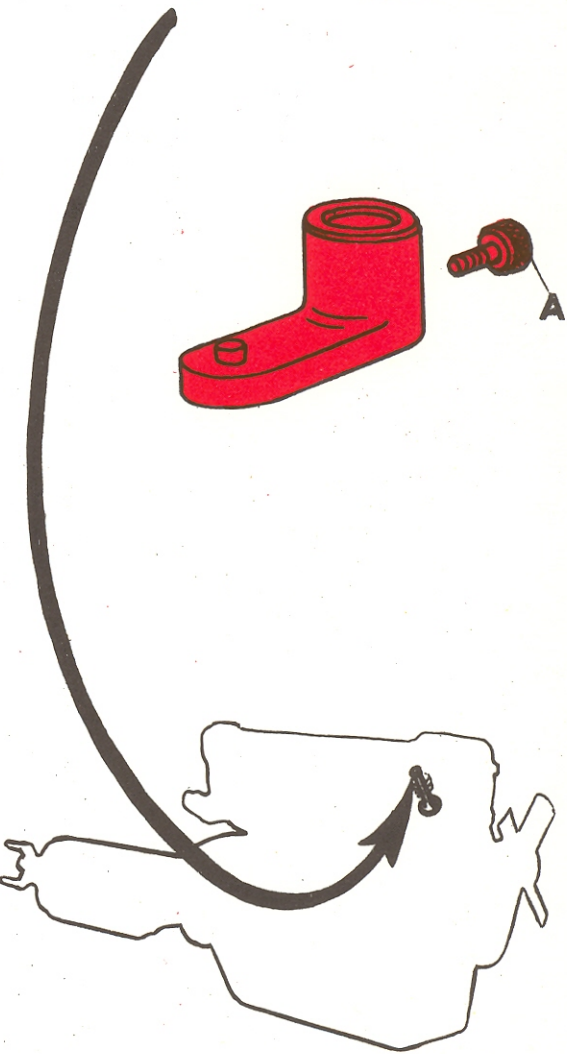
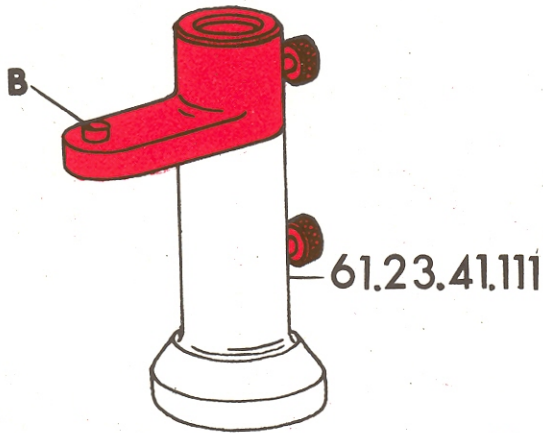

- 2 Fit a dial indicator 7600.31.002 on to the stand.

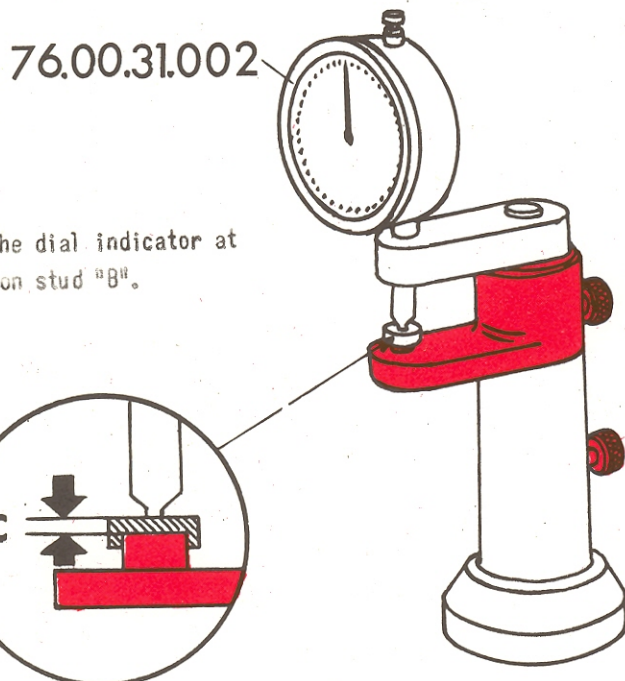

- 3 Set the dial indicator at zero on stud "B".

- 4 Select caps by fitting them over stud "B" and reading thickness "C" on the dial indicator.

GENERAL TOOLS	
SPECIAL TOOLS	X
MACHINERY	
EQUIPMENT	
MISCELLANEOUS	

# Alfa Romeo

DIREZIONE ASSISTENZA CLIENTI

DATE

30-4-1965

SEQUENT NUMBER

51/2

Giulietta - Giulia

2000 - 2600

## Tooling News

### SELECTION OF VALVE CLEARANCE ADJUSTING PAD

- ① Fit a dial gauge into the hole "A" and lock it by slightly tightening the setscrew "B".

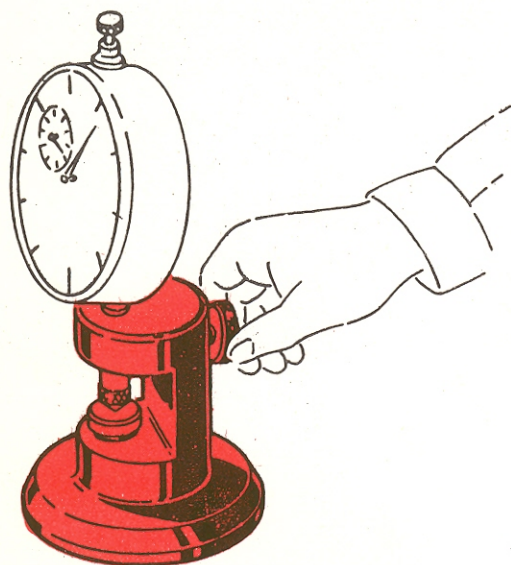

C. 5.0111/1

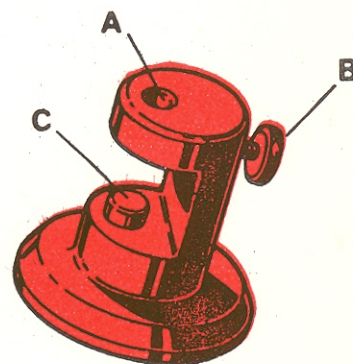

- ② Zero set the gauge against the reference plate "C" and select the proper thickness "S" of the adjusting pads by trial readings.

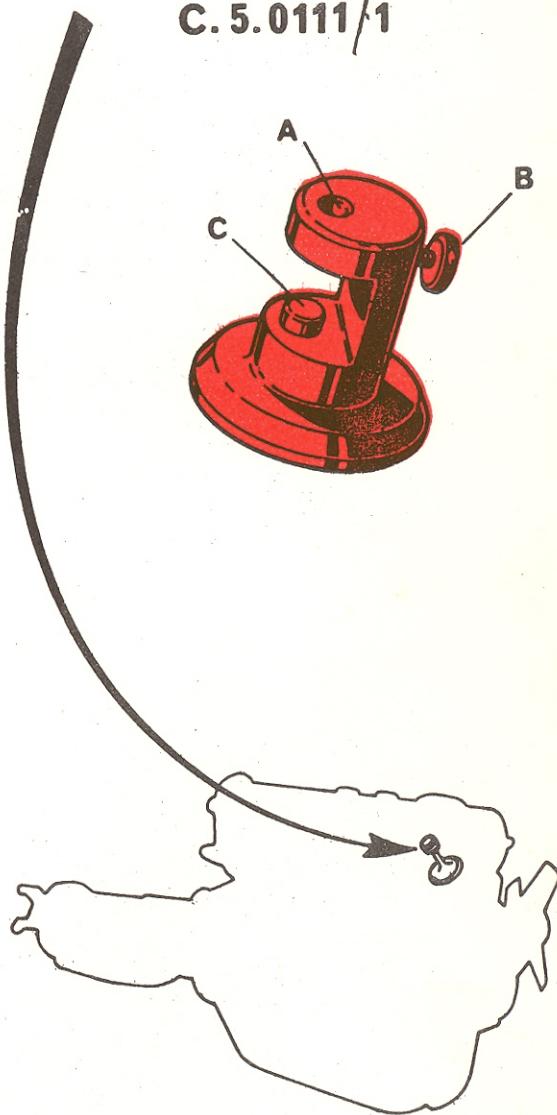
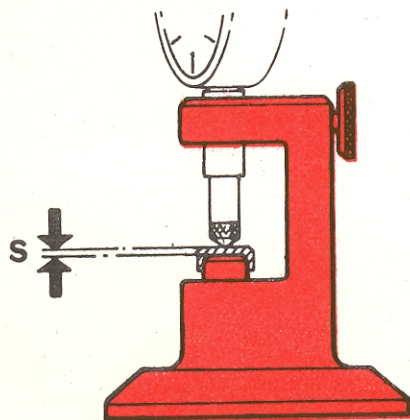

This T.N. deletes and super-  
sedes n. 51/1 dated 20/5/1964.

Translated in October 1965

GENERAL TOOLS	
SPECIAL TOOLS	X
MACHINERY	
EQUIPMENT	
MISCELLANEOUS	

# Alfa Romeo

DIREZIONE ASSISTENZA

## Tool Bulletin

DATE

30-11-1972

SEQUENT NUMBER

51/3

Giulia - 1750  
2000 - Montreal  
F 12 - Alfetta

### SELECTION OF VALVE CLEARANCE ADJUSTING PAD

- 1 Fit a conventional dial gauge, having a 10 mm total travel (e.g. C.1.0013 as shown) to the upper hole of the support C.5.0111/1.
- 2 Lock in place the dial gauge by slightly tightening the setscrew "B".
- 3 Zero set the dial gauge against the top of reference plate "C".
- 4 Select the proper thickness of the adjusting pads by putting them on the reference plate as shown in fig. 2 for trial readings.
- 5 Take accurate readings of the thickness "S".
- 6 To keep the adjusting pads in proper order use the suitable box R.2.0004.

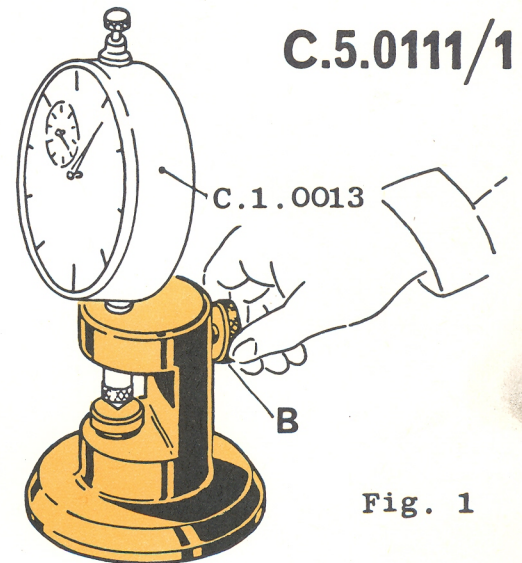

Fig. 1

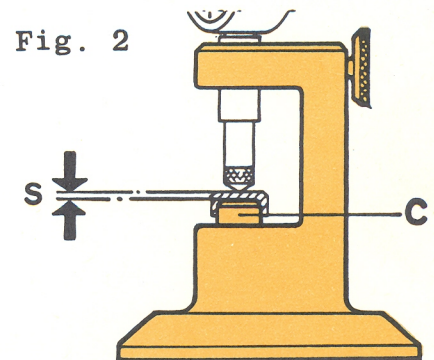
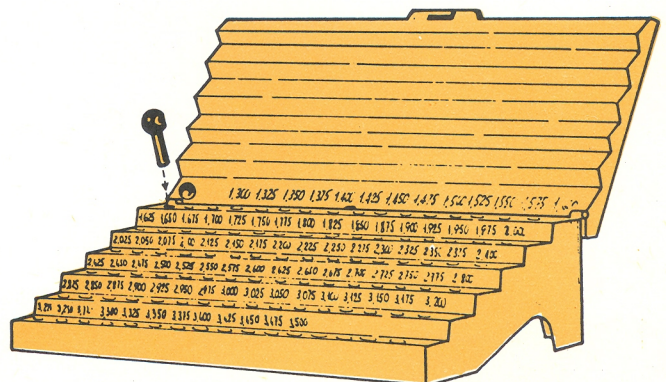

Fig. 2

R.2.0004



Deletes and supersedes T.B.  
No. 51/2 dated 30/4/1965

GENERAL TOOLS	
SPECIAL TOOLS	X
MACHINERY	
EQUIPMENT	
MISCELLANEOUS	

# Alfa Romeo

DIREZIONE ASSISTENZA

## Tool Bulletin

DATE

26-6-1975

SEQUENT NUMBER

51/4

Giulia - 2000  
Alfetta - Montreal  
F 12

**C.1.0108**

### SELECTION OF VALVE CLEARANCE ADJUSTING PADS

- 1 Check that dial gauge is properly set to zero. In the at-rest position the reading of the two needles "A" and "B" should be zero (see fig. 1).

If calibration is needed, slacken screw "C", adjust the pin "D" in position until the two needles are exactly set to zero then retighten screw "C".

- 2 Holding the dial gauge as shown at fig. 2 push button "E" until plunger "F" is fully lowered.

- 3 Put the adjusting pad on plunger as shown at fig. 2. Release plunger "F" and read the thickness of pad on dial bearing in mind that the larger scale shows hundredths of millimetres and the smaller scale millimetres.

- 4 To keep the adjusting pads in proper order use the box R.9.0001 shown at fig. 3.

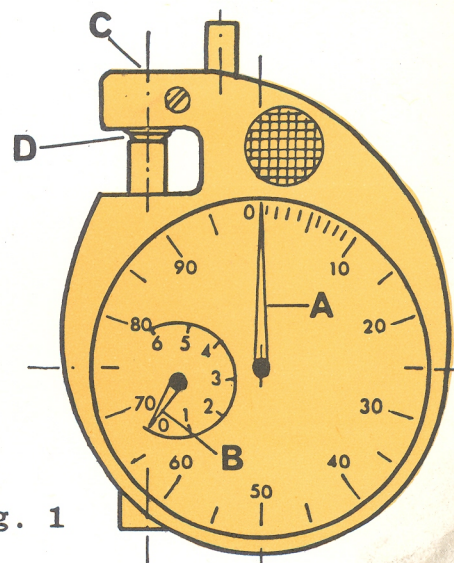

Fig. 1

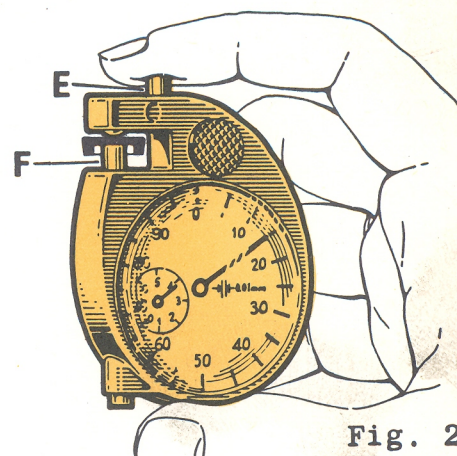

Fig. 2

**R.9.0001**

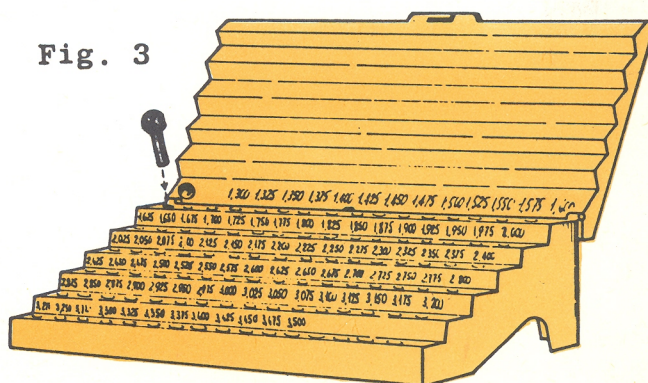

Fig. 3

Deletes and supersedes T.B.  
No. 51/3 dated 30/11/1972

GENERAL TOOLS	
SPECIAL TOOLS	X
MACHINERY	
EQUIPMENT	
MISCELLANEOUS	

# Alfa Romeo

DIREZIONE ASSISTENZA CLIENTI

DATE  
8 - 6 - 1961  
SEQUENT NUMBER  
53  
GIULIA - 2600  
**Giulietta  
2000  
ROMEO**

## Tooling News

### REMOVAL OF STEERING ARM

A.3.0119

- 1 Remove the nut and its locking device from the steering arm pin.

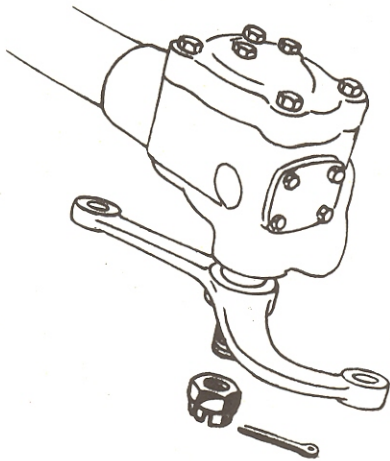

- 2 Screw nut "C" on to the steering arm pin.
- 3 Set the clamp "A" in position, adjusting nut "C" as required.

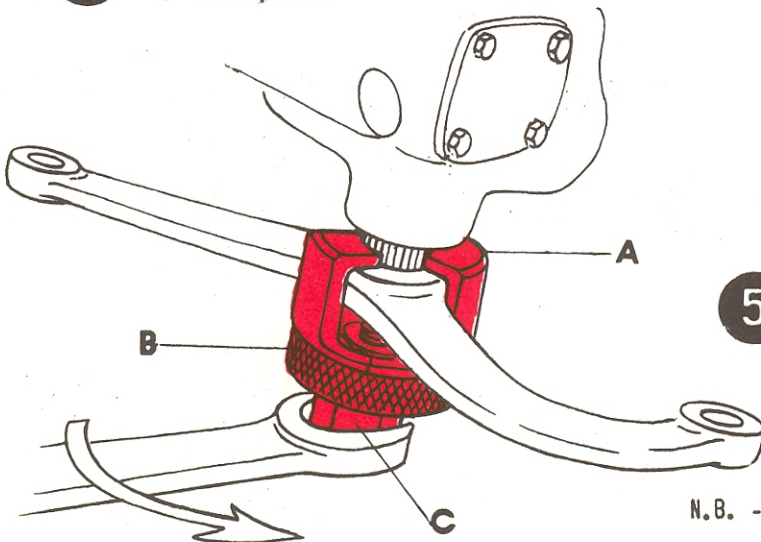

- 4 Fit ring "B".

- 5 Unscrew nut "C" with the correct spanner.

N.B. - Reverse nut "C" for the 2000.  
In the case of the Romeo the unit should be removed before this operation is carried out.

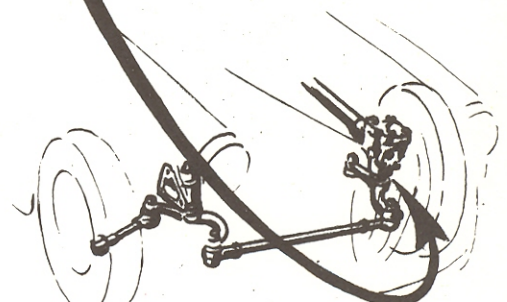
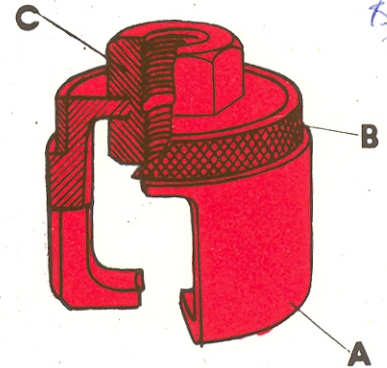

GENERAL TOOLS	
SPECIAL TOOLS	<b>X</b>
MACHINERY	
EQUIPMENT	
MISCELLANEOUS	

# Alfa Romeo

DIREZIONE ASSISTENZA

## Tool Bulletin

DATE

28-2-1973

SEQUENT NUMBER

**53/2**

Giulia - 1750  
2000 - Montreal

### STEERING DROP ARM WITHDRAWAL

**A.3.0119**

- 1 Remove the safety retainer and unscrew the drop arm nut.
- 2 Screw the nut "C" onto the steering box output shaft.
- 3 Place the jaws "A" in position on the arm by adjusting the position of nut "C".
- 4 Insert the ring "B".
- 5 Unscrew nut "C" with a suitable spanner to withdraw the arm.

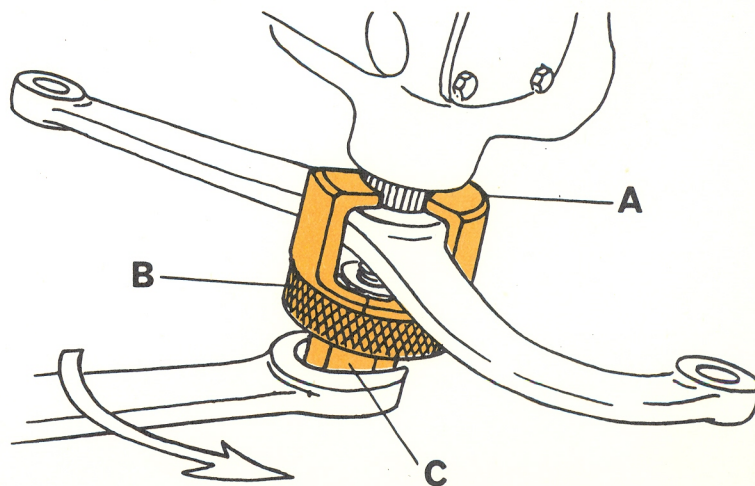
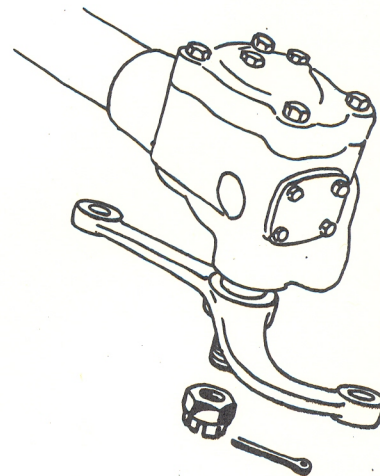
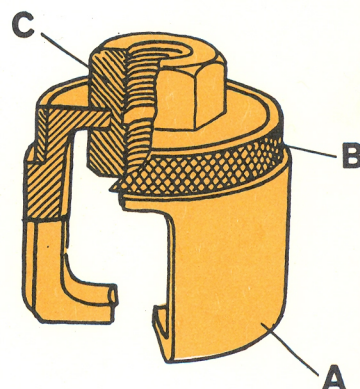

Deletes and supersedes T.B.  
No. 53/1 dated 20/5/1964

GENERAL TOOLS	
SPECIAL TOOLS	X
MACHINERY	
EQUIPMENT	
MISCELLANEOUS	

## Tooling News

### CHECKING PRE-LOAD OF WHEEL HUB BEARINGS

C.5.0109

ROMEO

- 1 Remove the front cover and the brake drum.

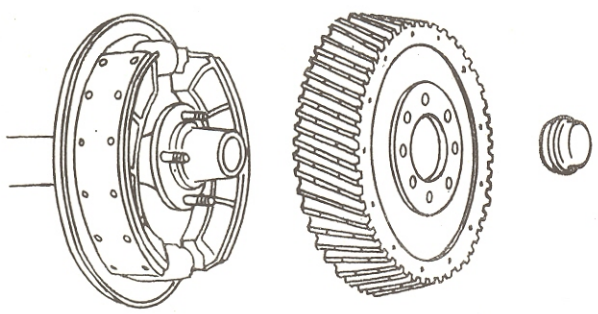

- 2 Adjust the bearings as described in the repair manual.
- 3 Fit the correct bracket and lock the lever in position by means of the nuts "A".

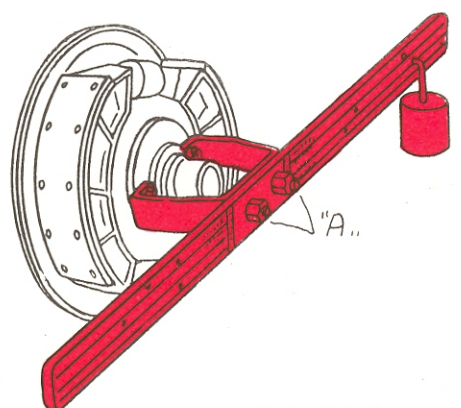

- 4 Fit the correct weights into the holes corresponding to the prescribed pre-loads and check.

N.B. - For the "2000" and the Romeo the bracket is fitted of the five existing screws. On the Romeo it is over two fitted to the drum.

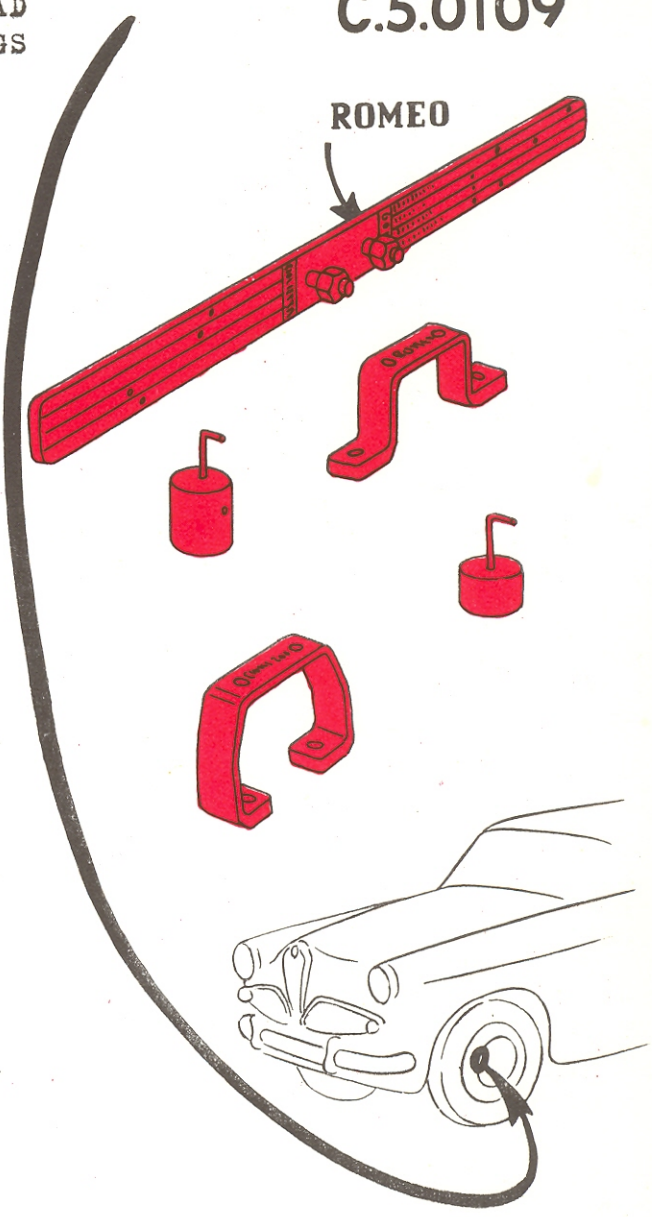

GENERAL TOOLS

SPECIAL TOOLS

X

MACHINERY

EQUIPMENT

MISCELLANEOUS

# Alfa Romeo

## DIREZIONE ASSISTENZA CLIENTI

### Tooling News

DATE

8 - 6 - 1961

SEQUENT NUMBER

57

2600  
**Giulietta**  
**2000**  
**ROMEO**

### GRINDING BRAKE LININGS

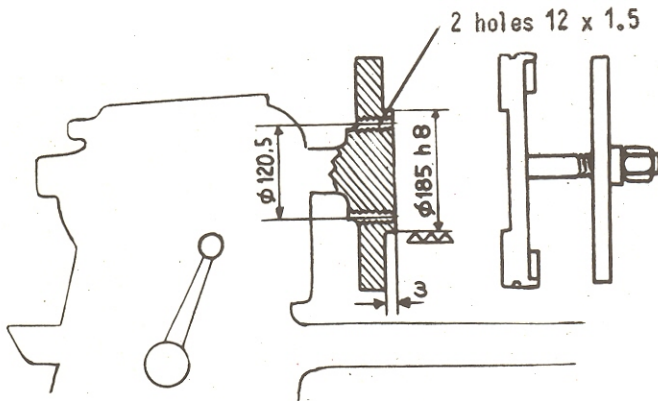

**1** A chuck-plate suitable for the measurements given in the sketch is needed for use in conjunction with the tool.

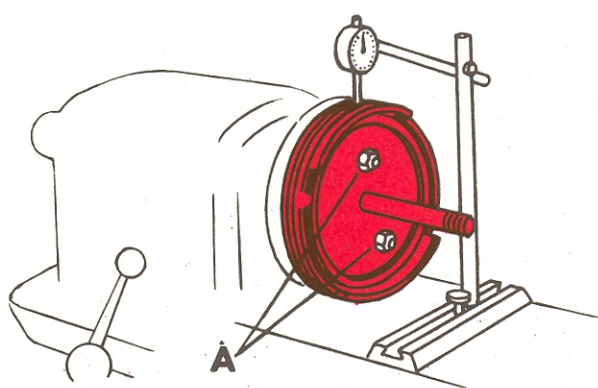

**2** Fit the tool and tighten the screws "A"; using a dial indicator, check that the tool is centred perfectly in the ground groove.

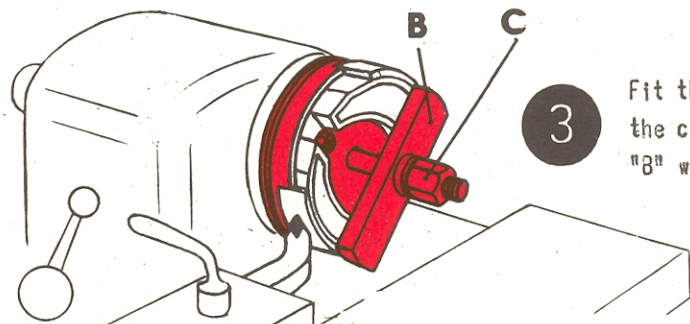

**3** Fit the shoes to be ground on to the tool, setting them in the correct reference positions and secure the crosspiece "B" with nut "C".

### A.4.0100

2000 2600

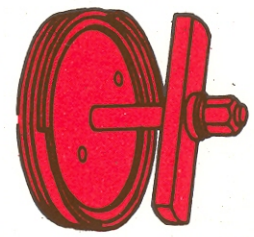

### A.4.0104

GIULIETTA (rear shoes)  
ROMEO

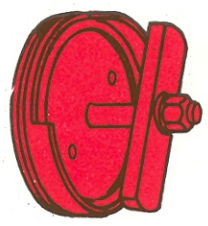

### A.4.0105

GIULIETTA (front shoes)

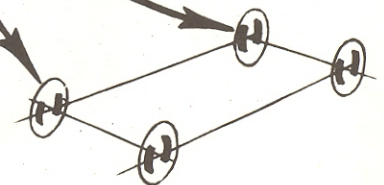
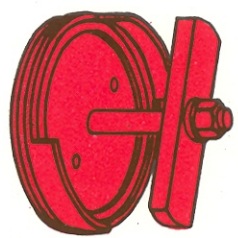

N.B. - These tools are supplied in place of the existing Nos. 6112.01.416 - 6112.01.323 6112.01.330 which can, however, still be used.  
 Cardisc International, Ltd. © Copyright 2004

GENERAL TOOLS	
SPECIAL TOOLS	<b>X</b>
MACHINERY	
EQUIPMENT	
MISCELLANEOUS	

# Alfa Romeo

## DIREZIONE ASSISTENZA CLIENTI

DATE  
30-6-1965

---

SEQUENT NUMBER  
**57/1**

## Tooling News

**Giulietta  
2000 - Romeo**

### GRINDING BRAKE LININGS

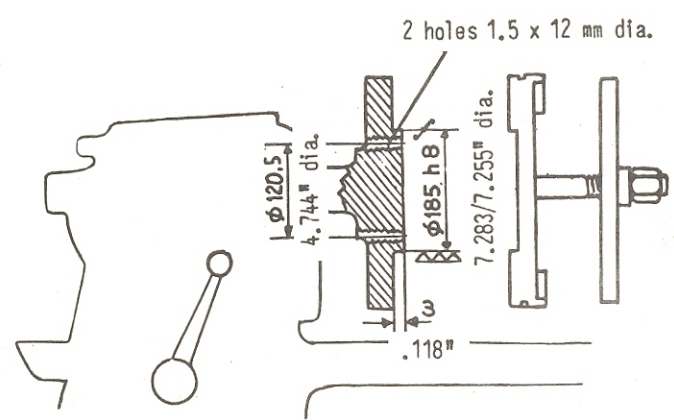

**1.** A chuck-plate complying with the dimensions given in the sketch is needed for use in conjunction with the tool.

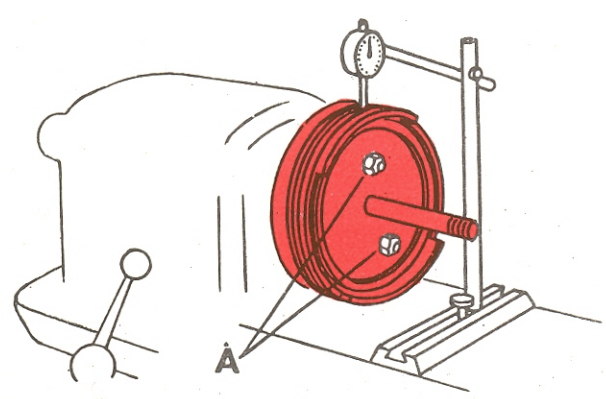

**2** Fit the tool and tighten the screws "A"; using a dial indicator in the ground groove, check that the tool rotates true.

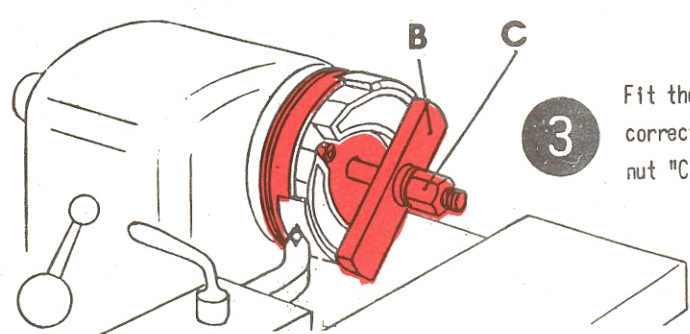

**3** Fit the shoes to be turned on to the tool, setting them in the correct reference positions and secure the crosspiece "B" with nut "C".

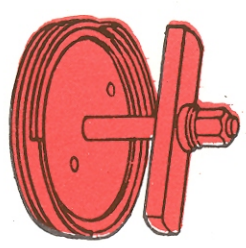

### A.4.0100

2000 - 2600  
Shoe P.N. { 102.00.22.201.00  
102.00.22.201.03

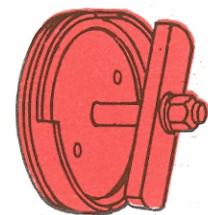

### A.4.0104

GIULIETTA - ROMEO  
Sheet metal { 1365.53.415  
shoe P.N. { 1365.53.426

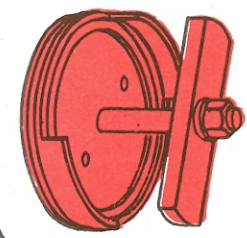

### A.4.0105

GIULIETTA  
Shoe P.N. 1365.53.043

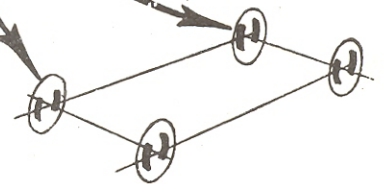

This T.N. deletes and supercedes no. 57 dated 8/6/1961.

N.B. - These tools are supplied in place of the existing Nos. 6112.01.416 - 6112.01.323 - 6112.01.330 which can, however, still be used. Copyright 2004

GENERAL TOOLS

SPECIAL TOOLS

X

MACHINERY

EQUIPMENT

MISCELLANEOUS

# Alfa Romeo

DIREZIONE ASSISTENZA

DATE

18-6-1966

SEQUENT NUMBER

61/3

## Tool Bulletin

Giulietta - Giulia  
2000 - 2600

### ALIGNING THE CAMSHAFTS

1

If the reference marks cut in the camshafts and those on the corresponding journal bearings are misaligned (refer to 2600 Shop Manual, page 18) slacken the screw "A" securing the sprocket to camshaft and remove the bolt "B" keying sprocket to camshaft flange.

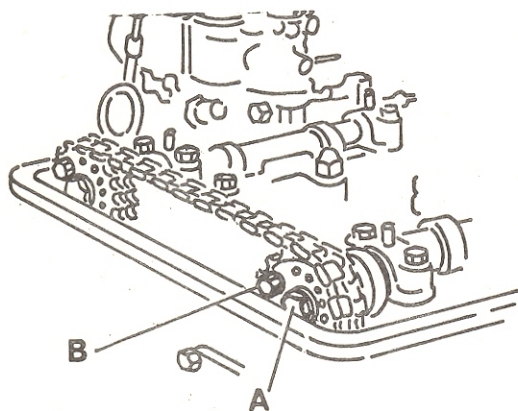

2

Insert the dowels "C" of the special tool in the holes of flange "D" and align the camshafts as required.

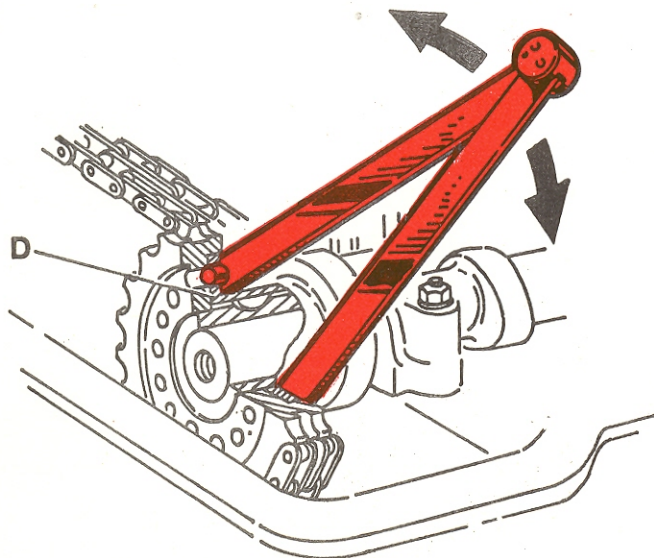

A.5.0103

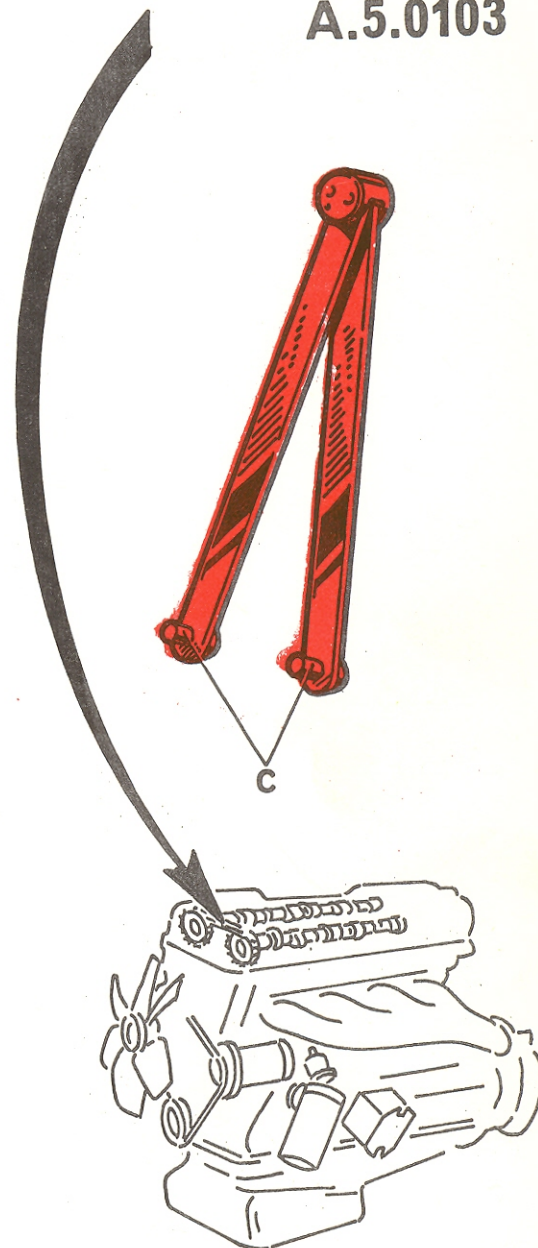

GENERAL TOOLS	
SPECIAL TOOLS	<b>X</b>
MACHINERY	
EQUIPMENT	
MISCELLANEOUS	

# Alfa Romeo

DIREZIONE ASSISTENZA

DATE

28-2-1973

SEQUENT NUMBER

**61/4**

Giulia - 1750  
2000 - Montreal  
Alfetta - F 12

## Tool Bulletin

**A.5.0103**

### ALIGNING THE CAMSHAFTS

- 1 If the reference marks cut in the camshafts and those on the relevant journal bearings are misaligned (refer to Shop Manual) slacken the screw "A" securing the sprocket to camshaft and remove the bolt "B" keying sprocket to camshaft flange.
- 2 Insert the dowels "C" of the special tool in the holes of flange "D" and align the camshafts as required.

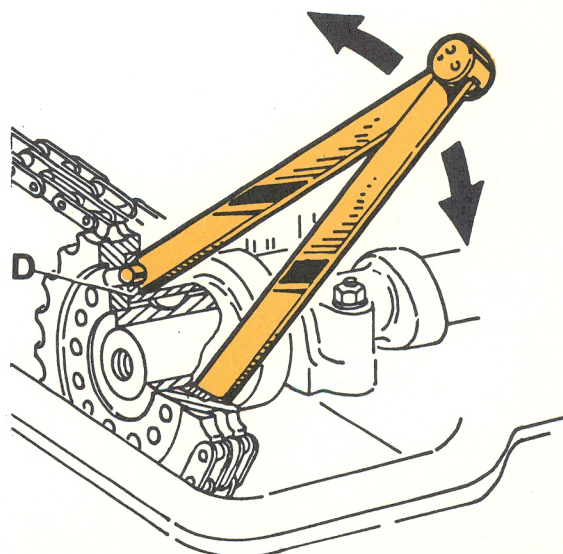
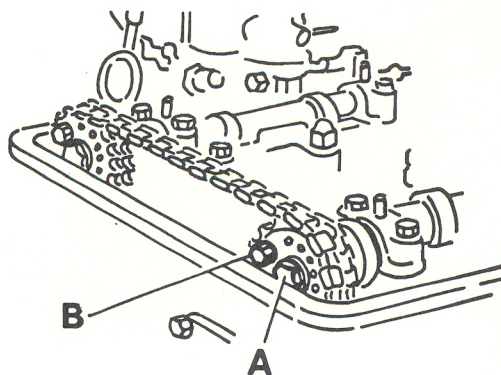

Deletes and supersedes T.B.  
No. 61/3 dated 18/6/1966

GENERAL TOOLS	
SPECIAL TOOLS	X
MACHINERY	
EQUIPMENT	
MISCELLANEOUS	

## Tooling News

### CHECKING OF PRE-LOAD STEERING ASSEMBLY BEARINGS

C.5.0112

- 1 Secure the steering unit to the bench, without steering wheel.
- 2 Disassemble steering shaft with roller.
- 3 Apply lever on steering wheel shaft.
- 4 Effect pre-load of the screw bearings, according to the values indicated on the lever, applying the needed spacers onto the lever cover.

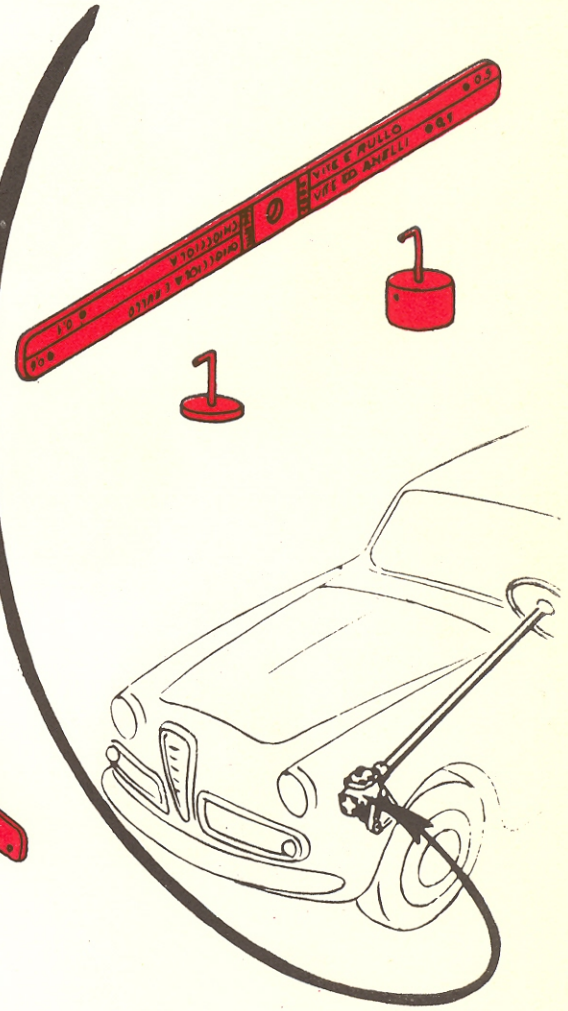
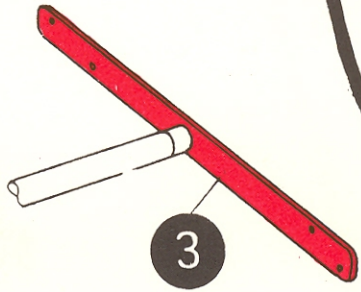
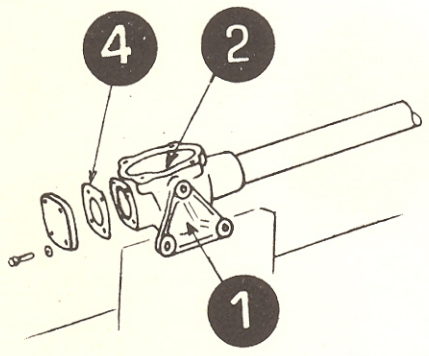

- 5 Re-assemble shaft with roller and regulate its position by checking the pre-load value allowed for screw and roller.

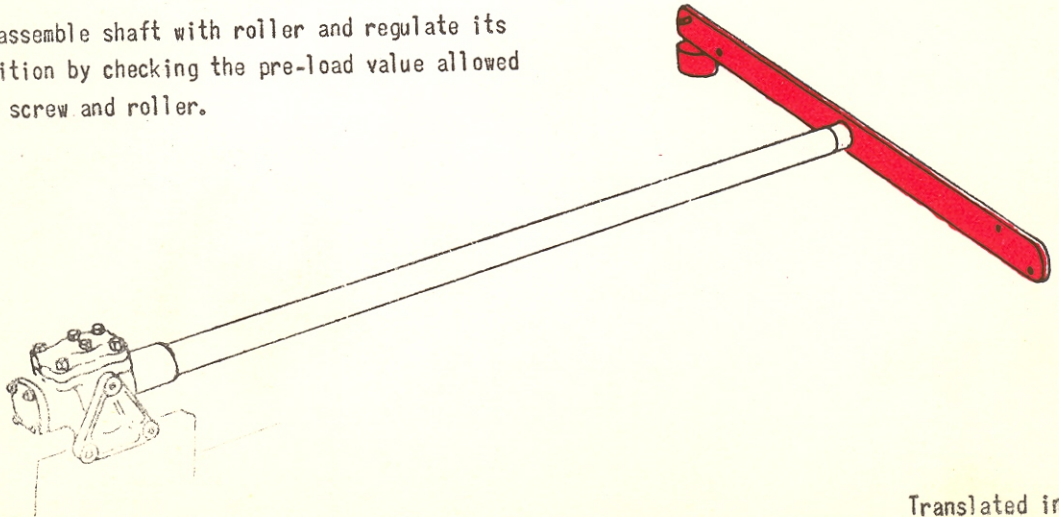

GENERAL TOOLS

SPECIAL TOOLS

X

MACHINERY

EQUIPMENT

MISCELLANEOUS

# Alfa Romeo

DIREZIONE ASSISTENZA

DATE

20-5-1964

SEQUENT NUMBER

62/1

**Giulietta**  
**2000 - 2600**

## Tool Bulletin

### CHECKING THE PRE-LOAD OF STEERING BOX BEARINGS

### C.5.0112

- 1 Secure the steering unit to the bench, without steering wheel.
- 2 Disassemble the rocker shaft with roller.
- 3 Apply the tool on steering wheel shaft.
- 4 Pre-load the bearings according to the values indicated on the lever by applying shims as required.

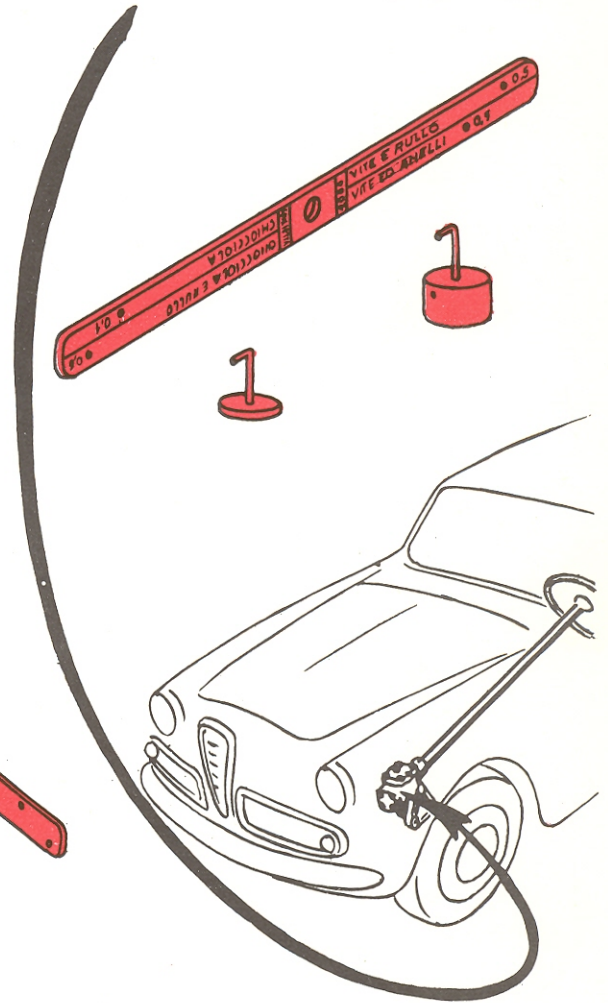
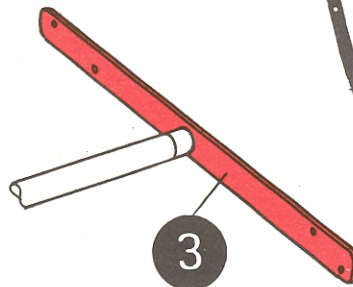
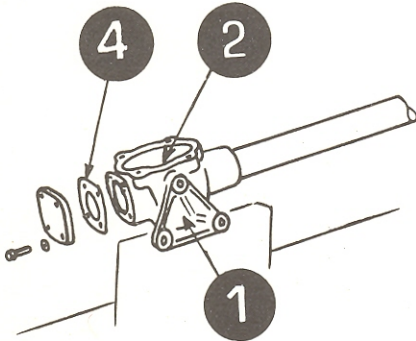

- 5 Re-assemble rocker shaft with roller and adjust its position until the pre-load value allowed for screw and roller is obtained.

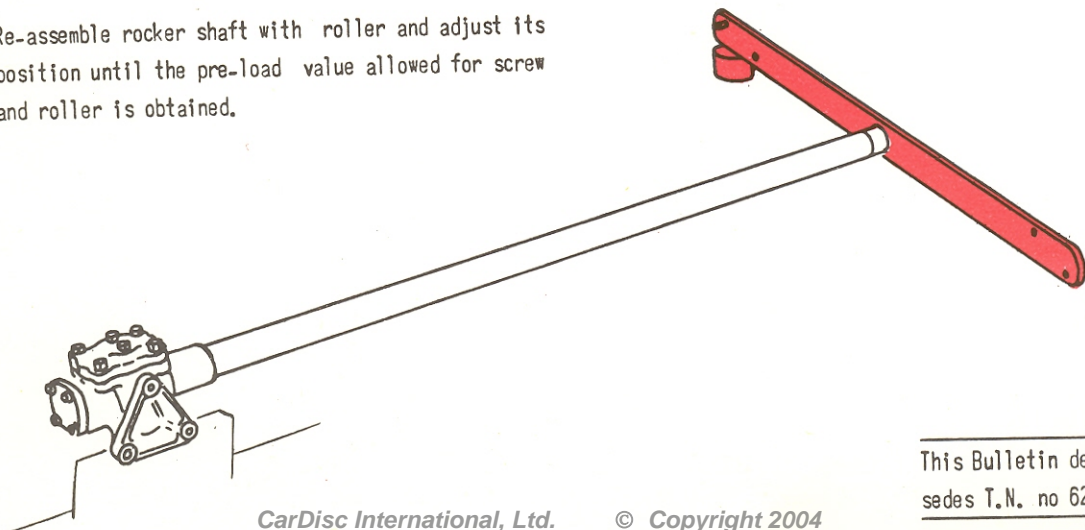

This Bulletin deletes and supersedes T.N. no 62 dated 30/10/961

GENERAL TOOLS

SPECIAL TOOLS

X

MACHINERY

EQUIPMENT

MISCELLANEOUS

# Alfa Romeo

DIREZIONE ASSISTENZA CLIENTI

DATE

30-6-1965

SEQUENT NUMBER

63/1

## Tooling News

Giulietta

### TURNING THE BRAKE LININGS

### A.4.0109

101.20.22.201.00 (3 shoe)

1365.53.026 } (2 shoe)  
101.20.26.201.00 }

1

Secure the brake-shoes to be turned onto the tool, adjusting them to the proper reference marks and then lock by means of backing plate "A". Use appropriate side of central support according to type of brakes, i.e. two-shoe or three-shoe. If need be, make the support for the brake-shoes as shown in drawing.

2

Place the tool so prepared on the points of a lathe.

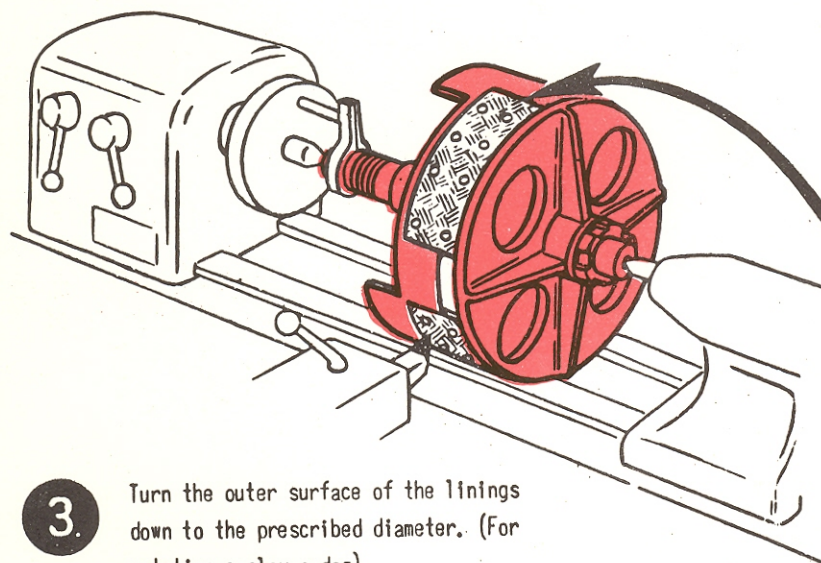

3

Turn the outer surface of the linings down to the prescribed diameter. (For rotation employ a dog).

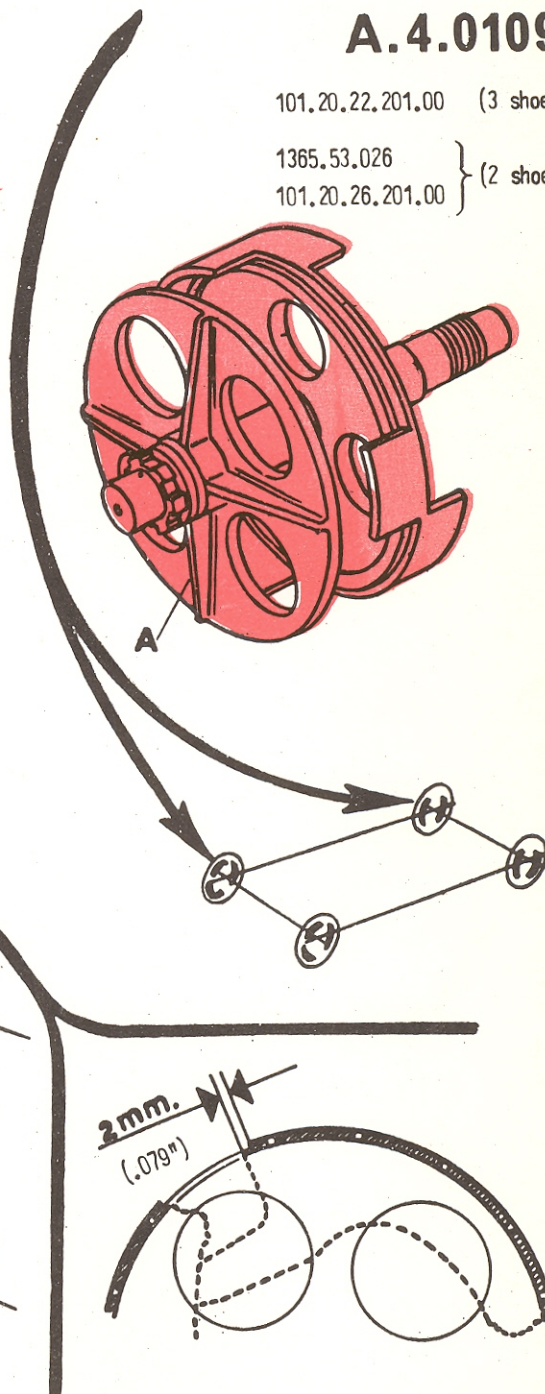

The tool is used for the following Giulietta models:

- a) Sprint speciale with 3-shoe front brakes and 2-shoe rear brakes
  - b) Sprint speciale with 2-shoe front brakes
  - c) Sprint veloce with 2-shoe front brakes
  - d) Spider veloce with 2-shoe front brakes
- } for the rear brakes use tool A.4.0104.

This T.N. deletes and supercedes no. 63 dated 15/1/1962

GENERAL TOOLS	
SPECIAL TOOLS	X
MACHINERY	
EQUIPMENT	
MISCELLANEOUS	

**Alfa Romeo**  
DIREZIONE ASSISTENZA CLIENTI

DATE  
**30-4-1965**

---

SEQUENT NUMBER  
**66/2**

---

**Giulietta - Giulia**  
**2000-2600**  
**Romeo (gasoline)**

*Tooling News*

**REMOVING THE OIL  
DRAIN PLUGS**

- ① Gain access to the underside of the car and have the oil drain plugs removed.  
If the unlocking proves difficult tap with a mallet on the end of the tool.  
This wrench applies for use with plugs P.N. 1306.10.098 and P.N. 1315.10.174 fitted on oil sump, gearbox and differential.

**A. 5.0106**

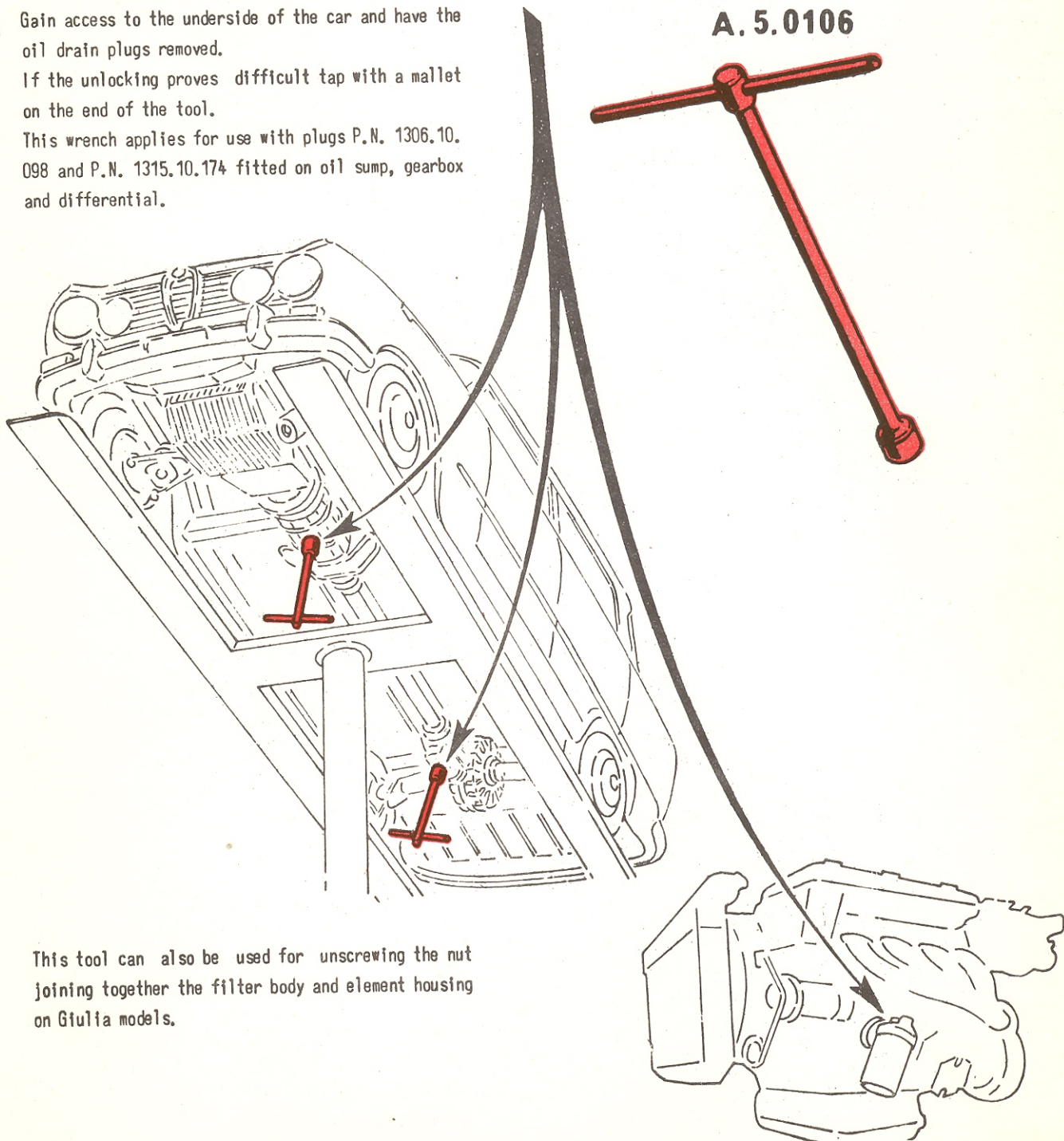

This tool can also be used for unscrewing the nut joining together the filter body and element housing on Giulia models.

Translated in October 1965

GENERAL TOOLS	X
SPECIAL TOOLS	
MACHINERY	
EQUIPMENT	
MISCELLANEOUS	

**Alfa Romeo**  
DIREZIONE ASSISTENZA CLIENTI

DATE  
10-6-1969

---

SEQUENT NUMBER  
**72/2**

---

GIULIETTA • GIULIA  
F-12 • 1750 • 2600

*Tooling News*

**DEVICE FOR BLEEDING CLUTCH AND BRAKE HYDRAULIC SYSTEM**

**R.2.0105**

F. 12  
(clutch circuit) - Mod. n° F. 12

Giulietta - Giulia - 1750  
(hydraulic clutch) - Mod. n° 4

2600 Mod. n° 7

Giulia (non-hydraulic clutch)  
Mod. n° 15

F. 12 (brake circuit)

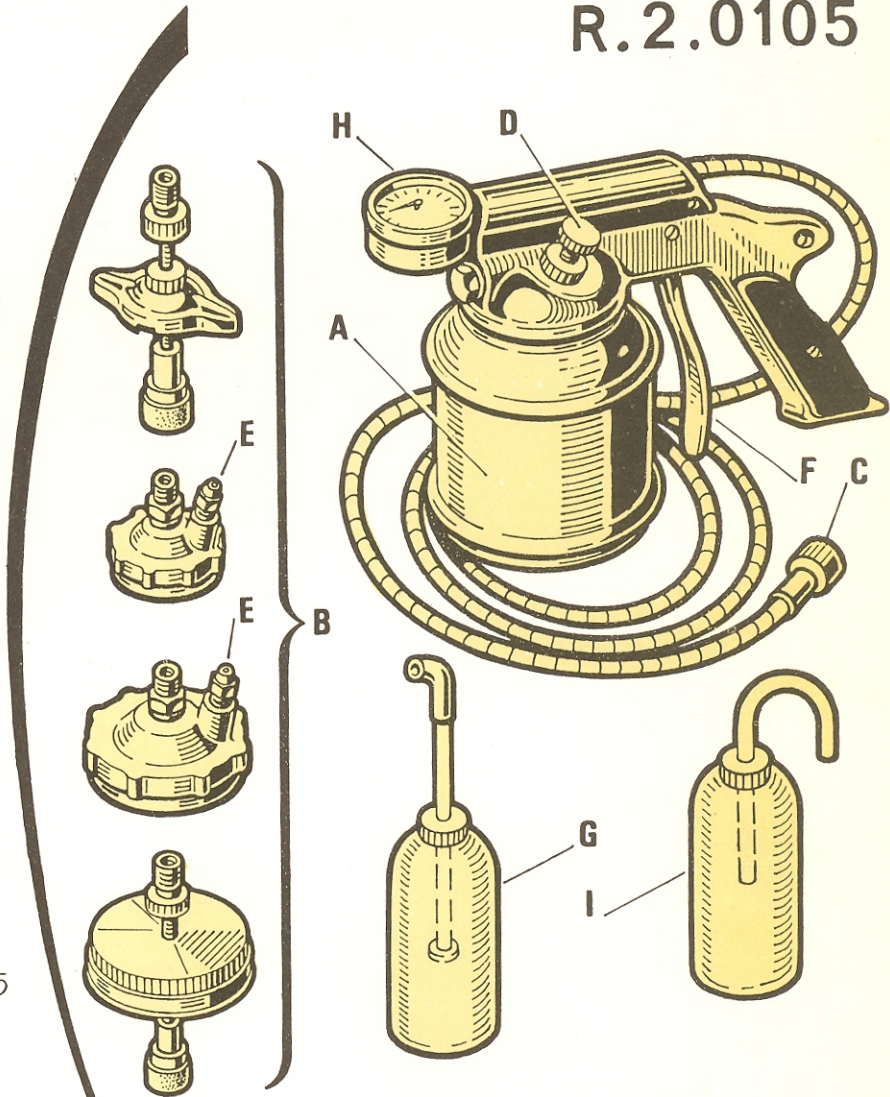

(operating diagram)

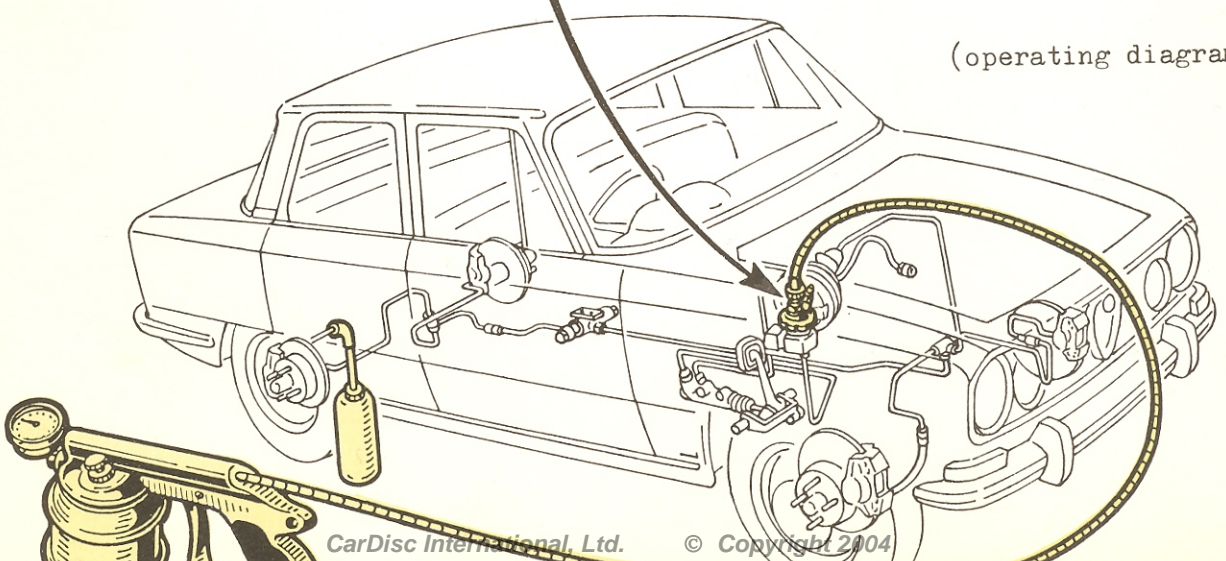

- 1 Place the vehicle on a lift or similar.
- 2 Properly protect the areas around the brake and clutch fluid reservoir.
- 3 Fill the tank "A" of the gun with fresh fluid.
- 4 Remove the cover of fluid reservoir and, in its place, fit the adapter "B" as applicable.
- 5 Connect the hose "C" to the adapter "B".
- 6 Close the valve "D" and open the valve "E" of the adapter "B"; connect the container "G" to the valve "E" to avoid possible waste of fluid.
- 7 Operate the lever "F" of gun to fill up the reservoir with fluid. When all air has come out of the reservoir, close the valve "E" and open the valve "D" to relieve pressure.  
Take away the container "G".
- 8 From the underside of car, apply the container "G" to a bleed screw.
- 9 Close the valve "D" and operate the lever "F" to put the circuit under pressure. Never exceed a pressure of 42 psi (3 Kg/cm<sup>2</sup>) as indicated by the gauge "H".
- 10 Open the bleed screw and let the fluid escape until it is free from air bubbles. While doing this, a pressure of about 40 psi (2.8 Kg/cm<sup>2</sup>) should be maintained.
- 11 Close the bleed screw and take the container "G" away.
- 12 Repeat the bleeding procedure for each bleed screw both in the clutch and brake system.  
When bleeding is over, open the valve "D".
- 13 Disconnect the hose "C" from the adapter "B" and, by using the container "I", suck the excess fluid out thru the adapter.
- 14 Remove the adapter "B" and, again with the container "I", suck fluid until the specified level is reached.
- 15 Discharge the gun from all fluid left in and thoroughly flush the device with alcohol.

Note: after the circuit has been put under pressure as per 9 above, it is advisable to depress fully the brake pedal two or three times.

GENERAL TOOLS	X
SPECIAL TOOLS	
MACHINERY	
EQUIPMENT	
MISCELLANEOUS	

# Alfa Romeo

DIREZIONE ASSISTENZA

## Tool Bulletin

DATE	1-6-1973
SEQUENT NUMBER	72/4
All models	

### DEVICE FOR BLEEDING CLUTCH AND BRAKE HYDRAULIC SYSTEM

R.2.0105

The gun is supplied as an outfit including:

- 1 gun complete, R.2.0105/1
- 1 transparent bottle for fluid topping up, R.2.0129
- 2 transparent bottles for collecting bled fluid, R.2.0130
- 1 reservoir cap, R.2.0119 (identified as mod. 15) applicable to:
  - a) Giulia models having mechanically-operated clutch
  - b) F 12 (for brake circuit only)
- 1 reservoir adaptor, R.2.0127 (identified as mod. 4) applicable to:
  - a) Giulia - 1750 models having early-type hydraulic clutch
- 1 reservoir adaptor, R.2.0128 (identified as mod.22) applicable to:
  - a) Giulia - 1750 models having late-type hydraulic clutch; 2000, Montreal, Alfetta and Alfasud models.

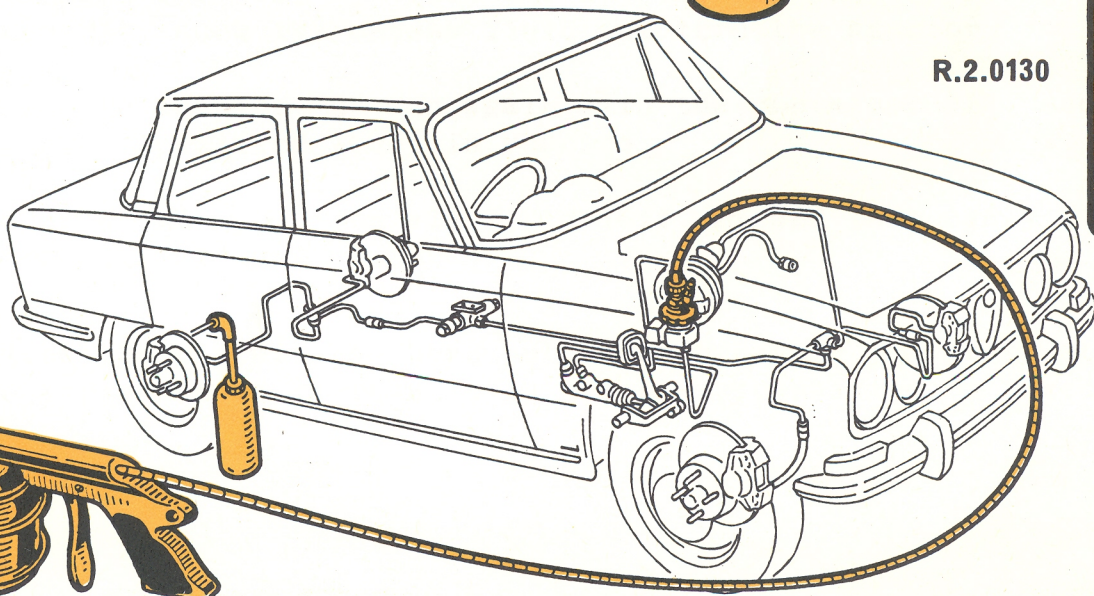
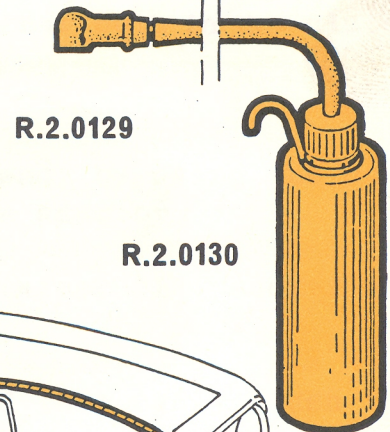
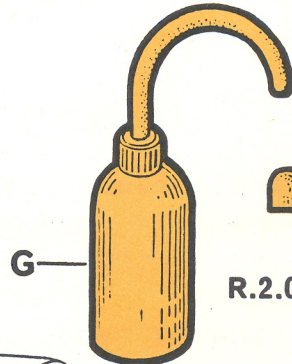
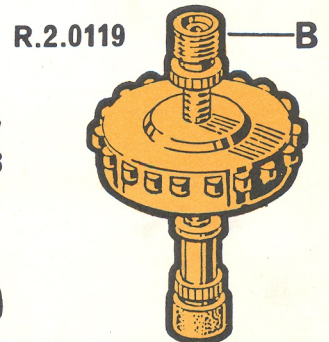
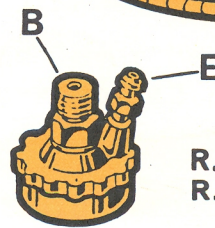
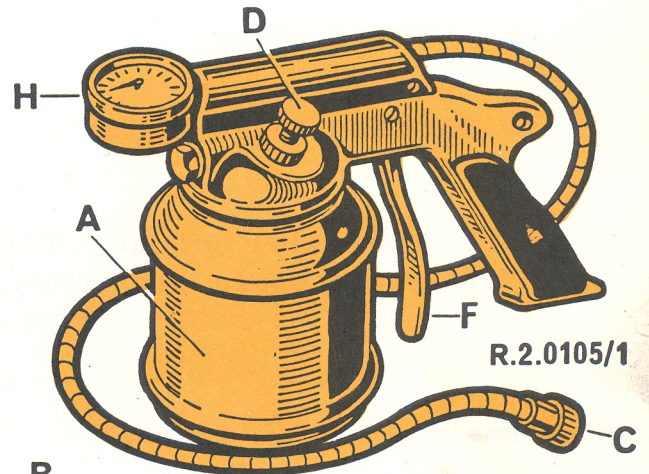

Deletes and supersedes I.B.  
 No. 72/3 dated 7/1/970

## PROCEDURE FOR SINGLE BRAKE CIRCUIT

- 1 Place the vehicle on a lift or similar.
- 2 Properly protect the areas around the brake and clutch fluid reservoir.
- 3 Fill by 3/4 the tank "A" of the gun with fresh fluid.
- 4 Remove the cover of fluid reservoir and, in its place, fit the adaptor "B" as applicable.
- 5 Connect the hose "C" to the adaptor "B".
- 6 Close the valve "D" and open the valve "E" of the adaptor "B"; connect the container "G" to the valve "E" to avoid possible waste of fluid.
- 7 Operate the lever "F" of gun to fill up the reservoir with fluid. When all air has come out of the reservoir, close the valve "E" and open the valve "D" to relieve pressure. Take away the container "G".
- 8 From the underside of car, apply the container "G" to a bleed screw.
- 9 Close the valve "D" and operate the lever "F" to put the circuit under pressure. Never exceed a pressure of 42 psi (3 Kg/cm<sup>2</sup>) as indicated by the gauge "H".
- 10 Open the bleed screw and let the fluid escape until it is free from air bubbles. While doing this, a pressure of about 40 psi (2.8 Kg/cm<sup>2</sup>) should be maintained.
- 11 Close the bleed screw and take the container "G" away.
- 12 Repeat the bleeding procedure for each bleed screw both in the clutch and brake system.  
When bleeding is over, open the valve "D".
- 13 Disconnect the hose "C" from the adaptor "B" and, by using the container "I", suck the excess fluid out thru the adaptor.
- 14 Remove the adaptor "B" and, again with the container "I", suck fluid until the specified level is reached.
- 15 Discharge the gun from all fluid left in and thoroughly flush the device with alcohol.

Note: After the circuit has been put under pressure as per 9 above, it is advisable to depress fully the brake pedal two or three times.

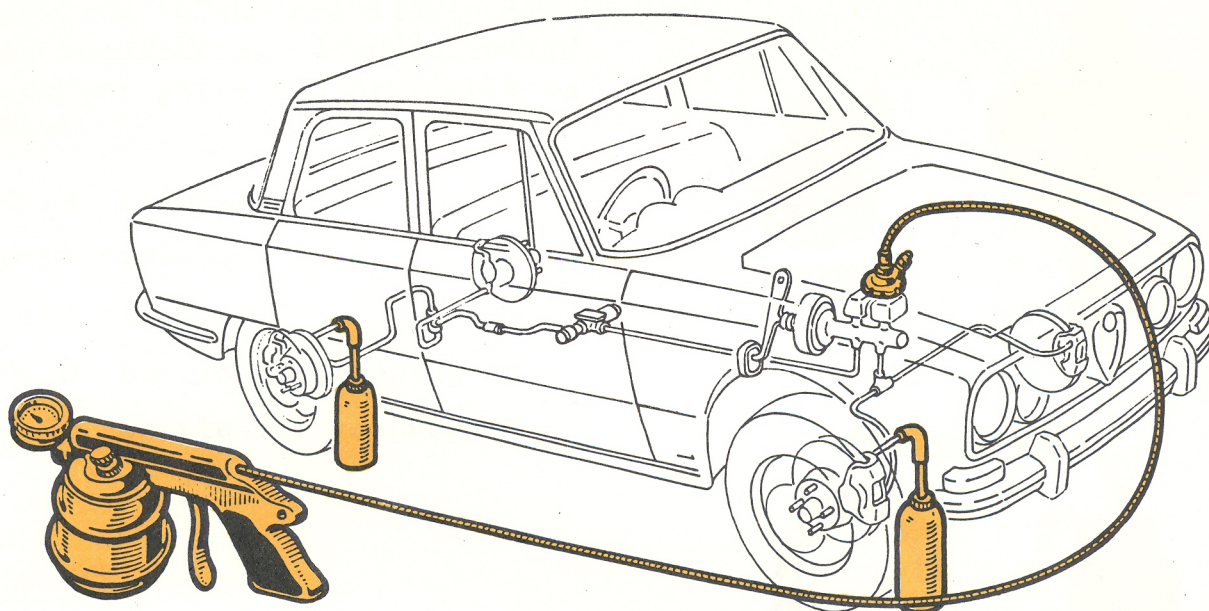

#### PROCEDURE FOR DUAL BRAKING SYSTEM

- 1 Perform the steps 1 through 7 as per sheet 2.
- 2 From the underside of car, apply the containers "G" to the bleed screws, one at the front wheel and one at the rear wheel.
- 3 Close the valve "D" and operate the lever "F" to put the circuit under pressure. Never exceed a pressure of 42 psi (3 Kg/cm<sup>2</sup>) as indicated by the gauge "H". At this stage, depress the brake pedal two or three times.
- 4 Open the bleed screws and let the fluid escape until it is free from air bubbles. While doing this, a pressure of about 40 psi (2.8 Kg/cm<sup>2</sup>) should be maintained.
- 5 Close the bleed screws and take the containers "G" away.
- 6 Repeat the bleeding procedure for the other two wheels and when the bleeding is over, open the valve "D" to relieve pressure.
- 7 Disconnect the hose "C" from the adaptor "B" and, by using the container "I" suck the excess fluid out thru the adaptor.
- 8 Remove the adaptor "B" and, again with the container "I" suck fluid until the specified level is reached.
- 9 Discharge the gun from all fluid left in and thoroughly flush the device with alcohol.

In addition to the previously mentioned accessories, the following replacement parts are available on request:

- R.2.0119 adaptor
- R.2.0127 adaptor
- R.2.0128 adaptor
- R.2.0129 bottle for topping up
- R.2.0130 bottle for recovery

GUN SPARES

- R.2.0105/14 tank
- R.2.0105/35 delivery pipe with fitting
- R.2.0105/4 shield
- R.2.0136 pump unit (assembled)
- R.2.0105/45 pressure gauge
- R.2.0137 dial protective glass

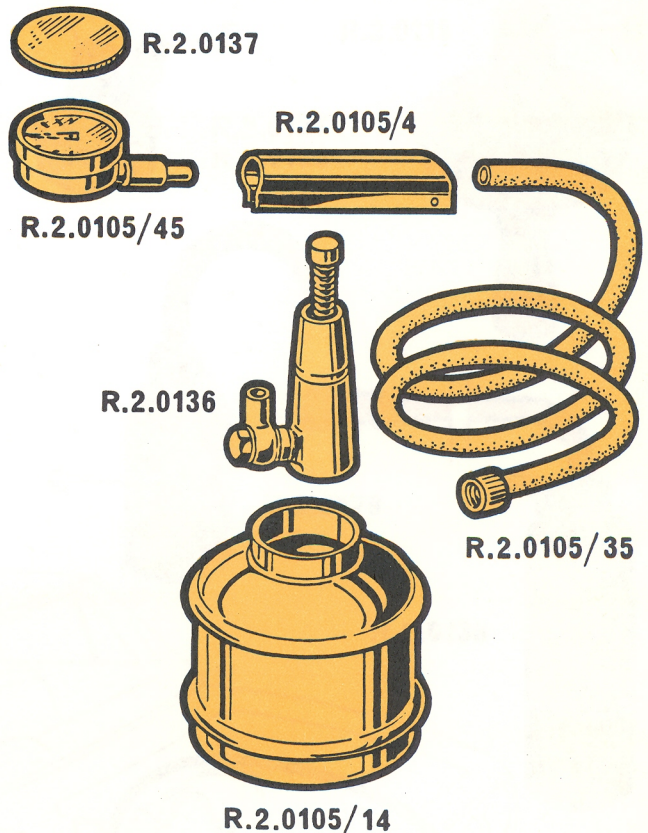
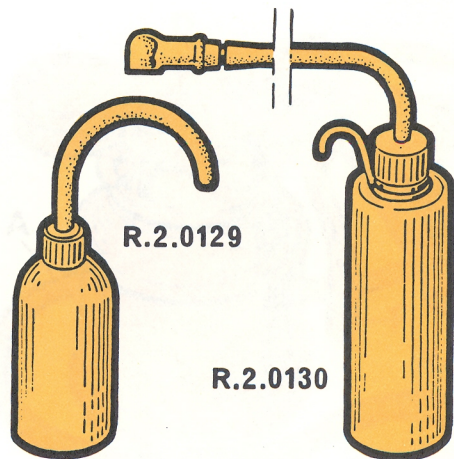
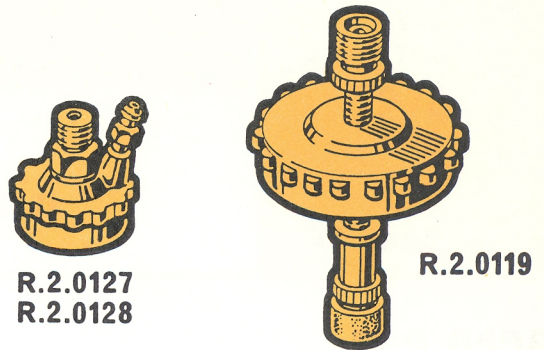

GENERAL TOOLS	
SPECIAL TOOLS	X
MACHINERY	
EQUIPMENT	
MISCELLANEOUS	

# Alfa Romeo

DIREZIONE ASSISTENZA CLIENTI

DATE	19-5-1962
SEQUENT NUMBER	73
MILLE	GIULIETTA
ROMEO	2000
2600	1600

## Tooling News

### RIVETTING BRAKE LININGS ONTO BRAKE-SHOES

**A. 2.0115**  
GIULIETTA 2000 ROMEO  
2600 1600

- 1 Make sure that the linings are not deformed and that the inside surfaces adhere to the supporting surfaces of the brake-shoes.
- 2 Apply two clamps close to the holes located in the middle of the lining and secure the lining in the exact position.

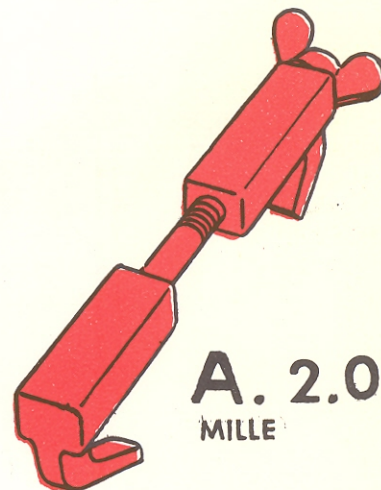
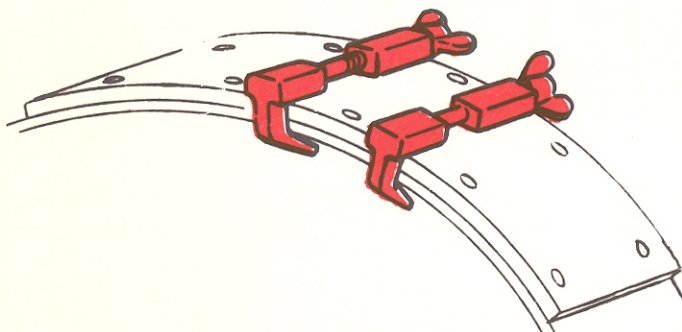

**A. 2.0116**  
MILLE

- 3 Proceed with the application of other clamps towards the ends of the linings, securing them one after the other in the order indicated.

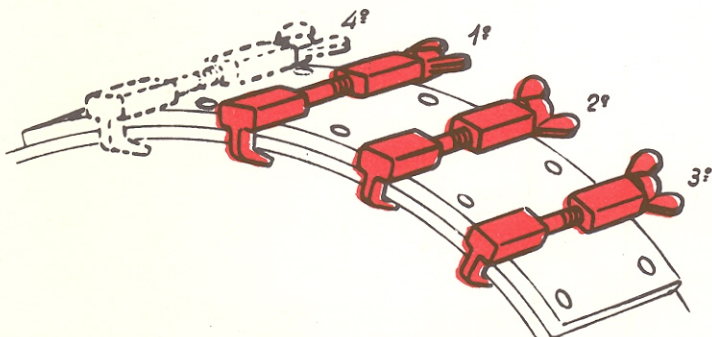

- 4 Before rivetting make sure that the holes of the lining correspond exactly with the holes of the brake-shoes. If necessary touch up lightly the holes of the lining.
- 5 Proceed with the rivetting. When the operation is completed, by striking lightly throughout the whole length of the lining with a hammer, there should be a metallic sound

N.B. - The tool A.2.0115 is supplied in replacement of the existing tool 6121.70.014 which is still serviceable.

GENERAL TOOLS

SPECIAL TOOLS

X

MACHINERY

EQUIPMENT

MISCELLANEOUS

# Alfa Romeo

DIREZIONE ASSISTENZA

DATE

20-5-1964

SEQUENT NUMBER

74/1

## Tool Bulletin

**Giulietta - Giulia  
2000-2600-Mille**

### TIGHTENING THE RING NUT OF FINAL DRIVE PINION

Apply the tool (A.3.0183 or A.3.0184) on the pinion shaft yoke, screw in the ring nut and lock it with the tool A.5.0104 (Giulietta-Giulia) or A.5.0114 (2000-2600) and a torque wrench.

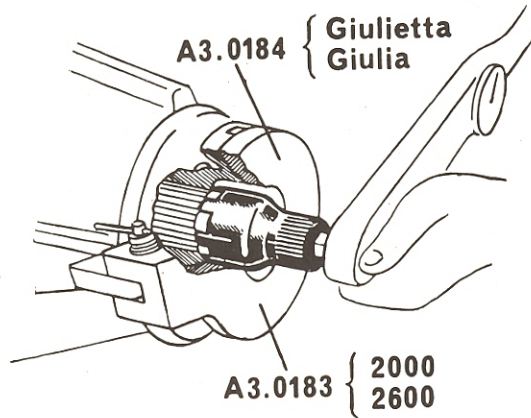

### A.5.0104

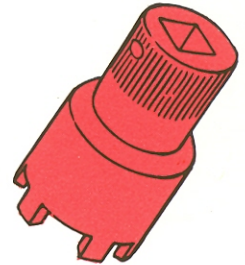

### TIGHTENING THE RING NUT OF CRANKSHAFT PULLEY

#### 2000 and 2600 Engine

Screw in the ring nut and lock it with tool A.5.0114 and a torque wrench.

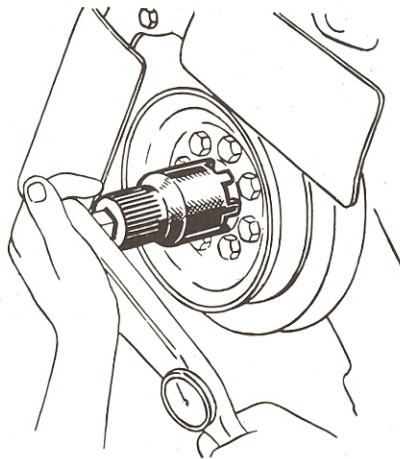

### A.5.0114

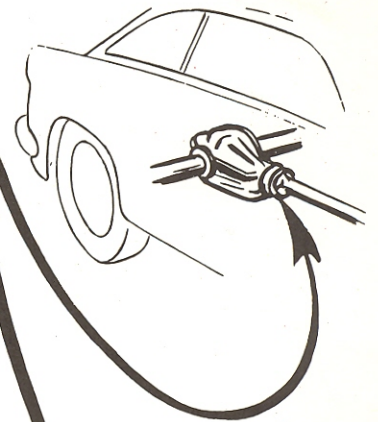

### TIGHTENING THE RING NUT OF INTERMEDIATE TIMING GEAR

#### Mille Engine

Screw the ring nut onto the gear shaft and lock with tool A.5.0114 and a torque wrench.

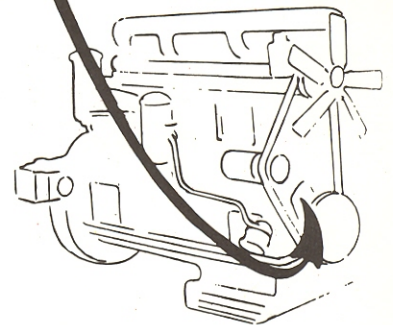
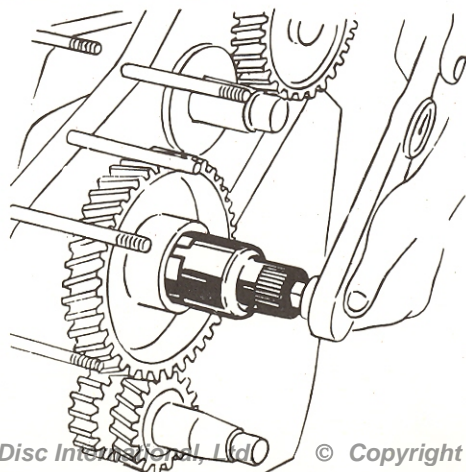

N.B. - For tightening torque specifications refer to the Shop Manual.

This Bulletin deletes and supersedes T.N. no 74 dated 18/3/1962

GENERAL TOOLS

SPECIAL TOOLS

X

MACHINERY

EQUIPMENT

MISCELLANEOUS

# Alfa Romeo

DIREZIONE ASSISTENZA

## Tool Bulletin

DATE

28-9-1966

SEQUENT NUMBER

76/1

Giulietta - Giulia  
2600

### LOCKING CYLINDER HEAD IN A VICE

### A.2.0108/1

- 1 Place the tool in a vice and direct support "A" as desired. This support can also be tilted around pivot "B".

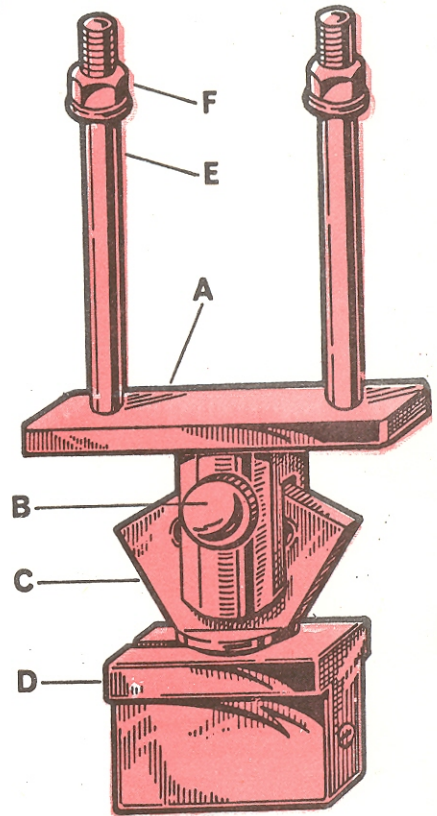
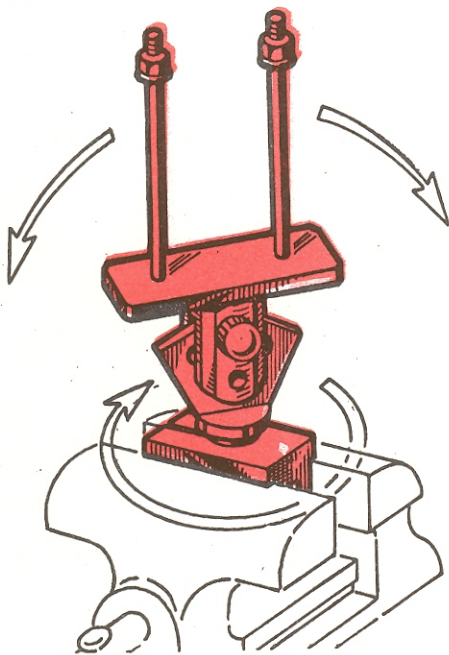

- 2 Clamp quadrant "C" in block "D".
- 3 Install cylinder head on tool passing tie-rods "E" through so that weight of head is equalized. Screw in and tighten nuts "F".

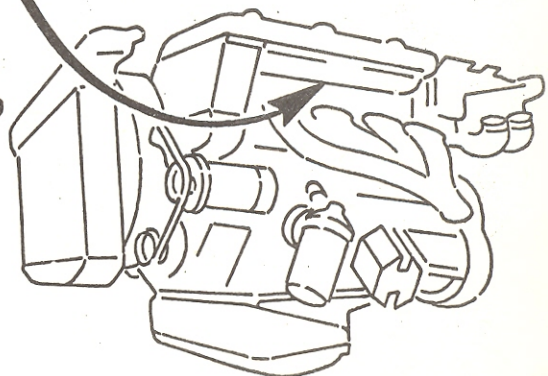
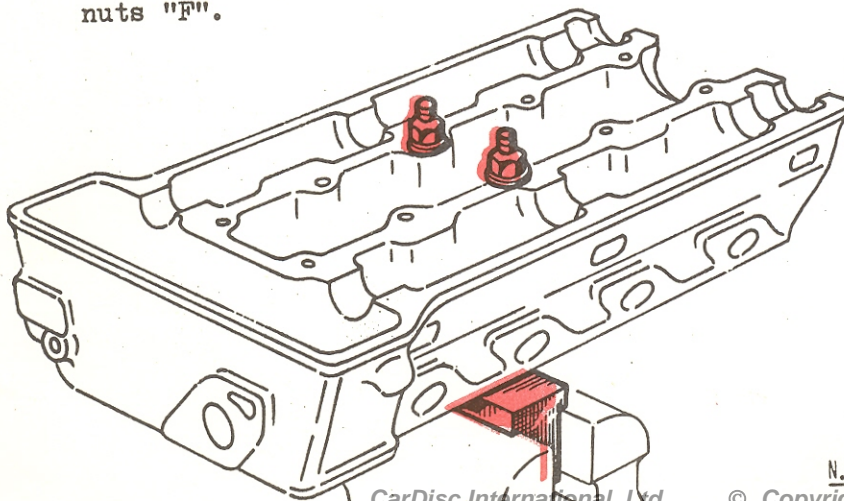

GENERAL TOOLS	
SPECIAL TOOLS	X
MACHINERY	
EQUIPMENT	
MISCELLANEOUS	

# Alfa Romeo

DIREZIONE ASSISTENZA

## Tool Bulletin

DATE

27-4-1973

SEQUENT NUMBER

76/2

All models

### LOCKING CYLINDER HEAD IN A VICE

A.2.0195

- 1 Place the head supporting tool A.2.0195 in a vice.

Unscrew the wingnut "B" and withdraw the pin "A" from the tool. See fig. 1.

- 2 Operate the retaining device "C" and fit the tool applicable to the cylinder head being overhauled, i.e.:

A.2.0196 for Giulia - 1750 - 2000 and Alfetta models

A.2.0197 for Montreal model

A.2.0226 for Alfasud model

Refit pin "A" and tighten the wingnut "B".

- 3 The retaining device "C" enables to position the trunnion, and thus the head on it, as required.

- 4 Place the head being overhauled on the tool so prepared; for best balancing of the weights use the centre holes in the head as shown at figure 2.

- 5 Fit the two washers "D" and tighten the two nuts "E" to secure the head to the tool (See figg. 2 and 3).

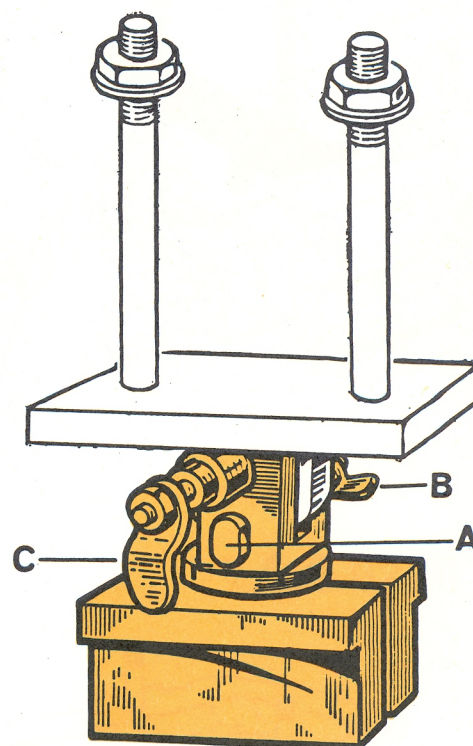

Fig. 1

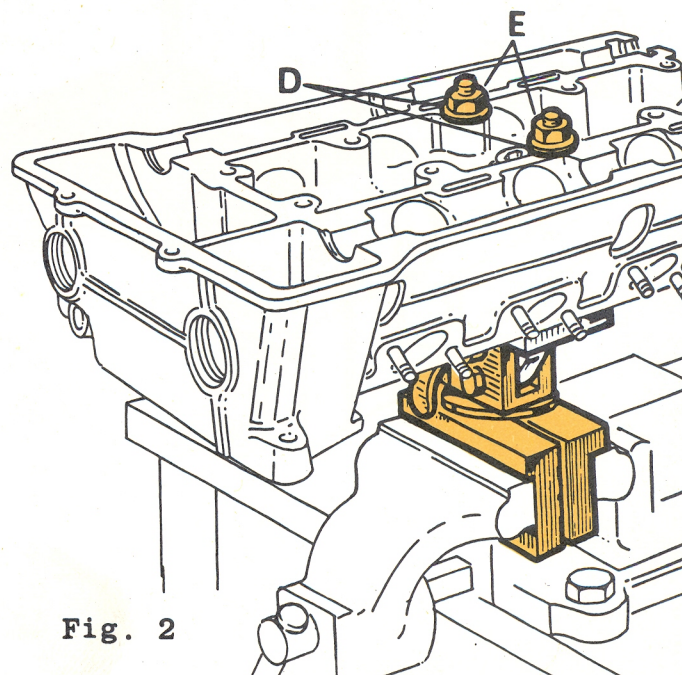

Fig. 2

Deletes and supersedes T.B.  
No. 76/1 dated 28/9/1966

A.2.0196

A.2.0197

- 6 For overhauling the cylinder head of the Alfasud model, the tool A.2.0226 should be used (See figure 4).

When performing overhauling operations at the top side (removal of valve cups, cotters and springs) slide the plate "F" in position to prevent valves from dropping out.

- 7 To remove the valves slide out the plate "F" and just withdraw the valves from the bottom through the opening "H" without removing the head from the tool (See fig. 4).

- 8 The head supporting tool allows to support the head in the position as installed on the block or upside down as required.

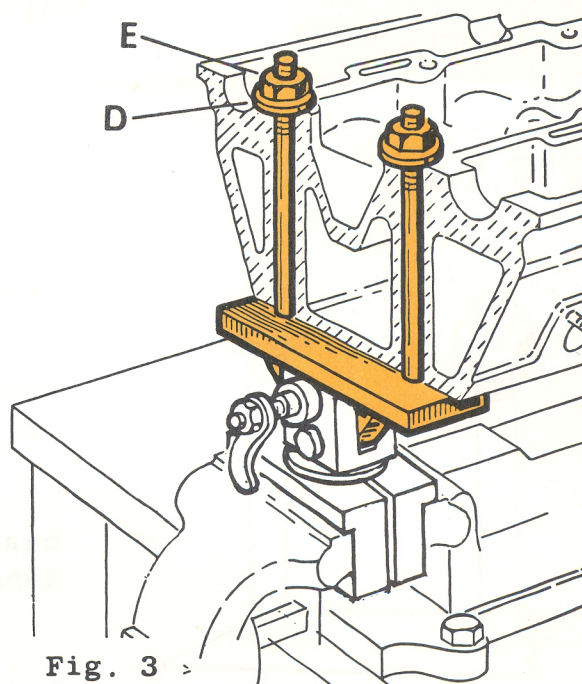

Fig. 3

A.2.0226

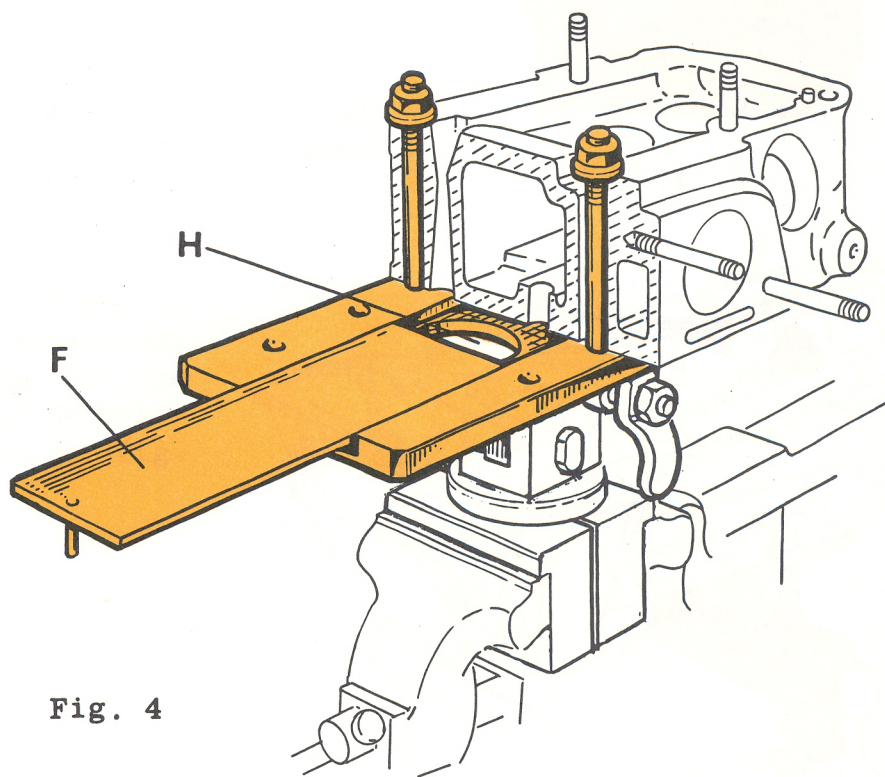

Fig. 4

GENERAL TOOLS	
SPECIAL TOOLS	<b>X</b>
MACHINERY	
EQUIPMENT	
MISCELLANEOUS	

# Alfa Romeo

DIREZIONE ASSISTENZA CLIENTI

DATE  
18-3-1969

SEQUENT NUMBER  
**77/1**

1300 - 1600  
1750 - 2600  
A15 - A19 - A38 - F20

## Tooling News

### RETAINING THE BARRELS IN CYLINDER BLOCK

#### A.2.0117

Set of two for  
1300-1600-1750 engines

#### A.2.0118

Set of three  
for 2600 engine

#### A.7.0105

Set of two for  
SAVIEM engines

- 1 Fit the set of tools, A.2.0117 or A.2.0118 as applicable, so that each tool retains two cylinder barrels as shown.
- 2 Lock in place the tools with nuts "A" (the same nuts used to secure the cylinder head).

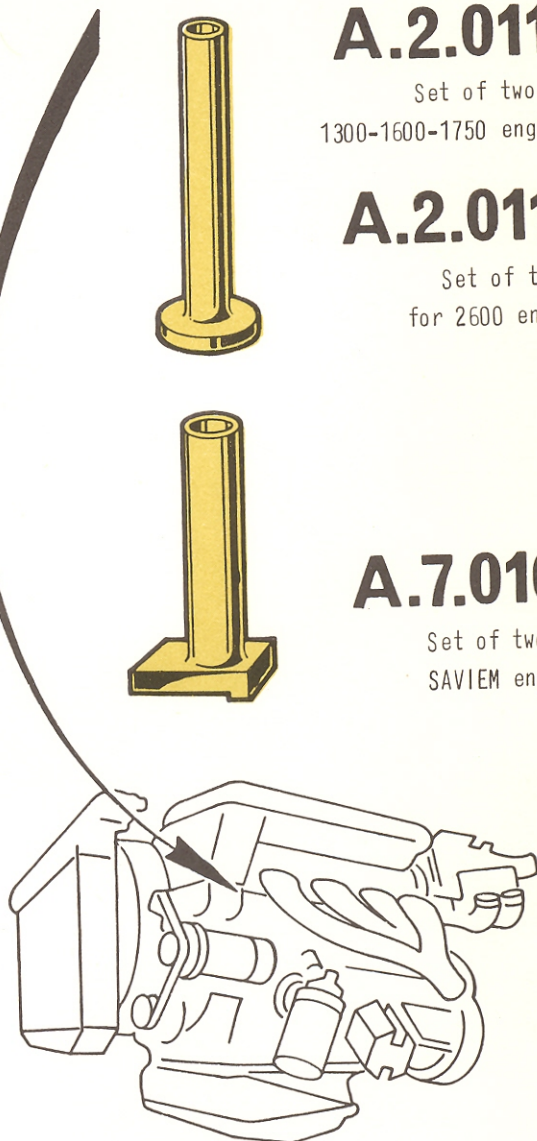
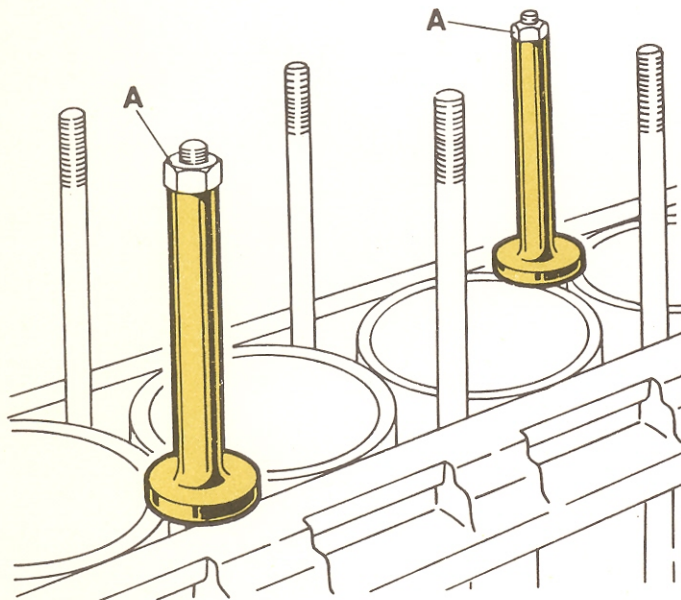

NOTE - To fit the 1750 engine studs, the bore of tool A.2.0117 has been enlarged from 12 mm to 12.5 mm. The old tools can however be used again by boring them accordingly.

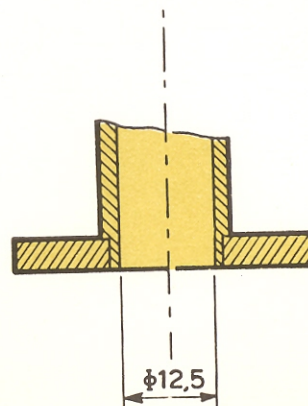

This Bulletin deletes and supersedes the I.B. no. 77 dated 19/5/1962

GENERAL TOOLS	
SPECIAL TOOLS	X
MACHINERY	
EQUIPMENT	
MISCELLANEOUS	

# Alfa Romeo

DIREZIONE ASSISTENZA

## Tool Bulletin

DATE

28-2-1973

SEQUENT NUMBER

77/2

All models  
except Alfasud

### RETAINING THE BARRELS IN CYLINDER BLOCK



**A.2.0117**  
Giulia - 1750  
2000 - Alfetta  
Set of two pieces

**A.2.0191**  
Montreal  
Set of four pieces

1

Fit the set of tools, A.2.0117, A.2.0191 or A.7.0105 as applicable, so that each tool retains two cylinder barrels as shown.

2

Lock in place the tools with nuts "A" (the same nuts used to secure the cylinder head).

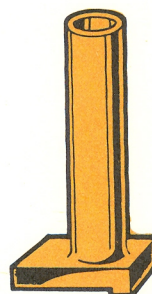

**A.7.0105**  
Saviem  
Set of two pieces

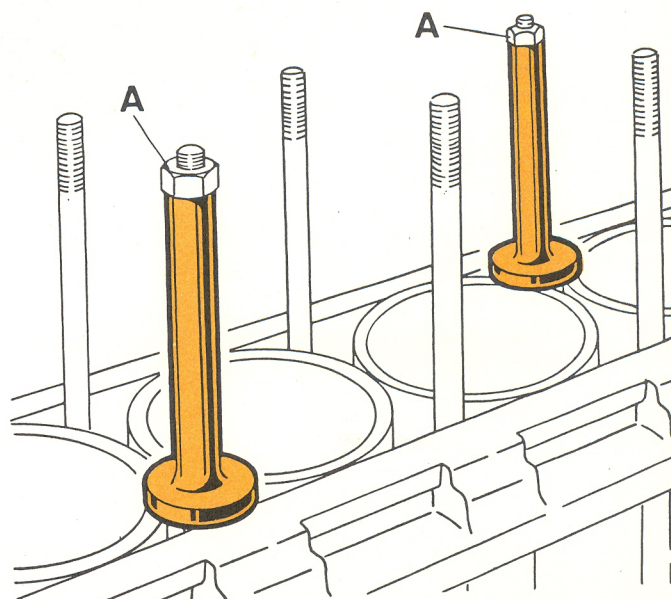

Deletes and supersedes T.B.  
No. 77/1 dated 18/3/1969

GENERAL TOOLS	
SPECIAL TOOLS	X
MACHINERY	
EQUIPMENT	
MISCELLANEOUS	

# Alfa Romeo

DIREZIONE ASSISTENZA

## Tool Bulletin

DATE

19-5-1962

SEQUENT NUMBER

78

GIULIETTA 2000

2600 1600

### CHECKING THE VALVE OPENING AND CLOSING ANGLES

### A. 2.012C

- 1 Remove the extension "A" from nut "B".
- 2 Secure the extension to the sensing needle of a dial indicator with the nut.
- 3 Mount the tool onto the stud on camshaft journal cap and lock in place with the nut "B".
- 4 Grip the dial indicator in the clamp "C" by the screw "D".
- 5 Have the extension end touching the valve cup ceiling.

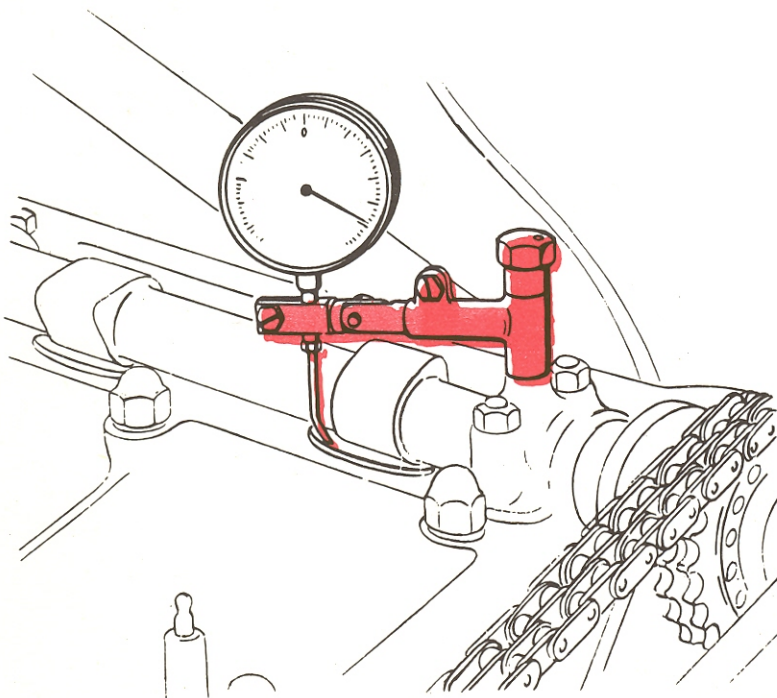
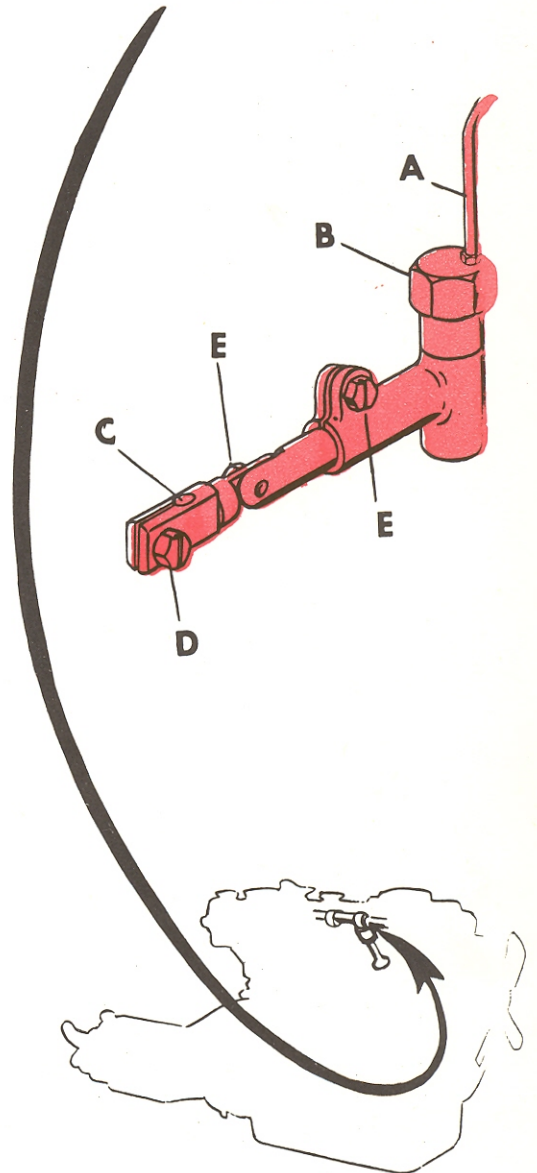

- 6 Take readings of valve opening and closing angles.

GENERAL TOOLS	
SPECIAL TOOLS	X
MACHINERY	
EQUIPMENT	
MISCELLANEOUS	

# Alfa Romeo

DIREZIONE ASSISTENZA

## Tool Bulletin

DATE

28-2-1973

SEQUENT NUMBER

78/1

Giulia - 1750  
2000 - Montreal  
Alfetta - F 12

### CHECKING THE VALVE OPENING AND CLOSING ANGLES

A.2.0120

- 1 Remove one of the extensions "A" from nut "B".
- 2 Secure the extension to the sensing needle of a dial indicator with the nut.
- 3 Mount the tool onto the stud on camshaft journal cap and lock in place with the nut "B".
- 4 Grip the dial indicator in the clamp "C" by the screw "D".
- 5 Have the extension end touching the valve cup ceiling.
- 6 Take readings of valve opening and closing angles on the dial gauge and on the protractor (refer to T.B. 140).

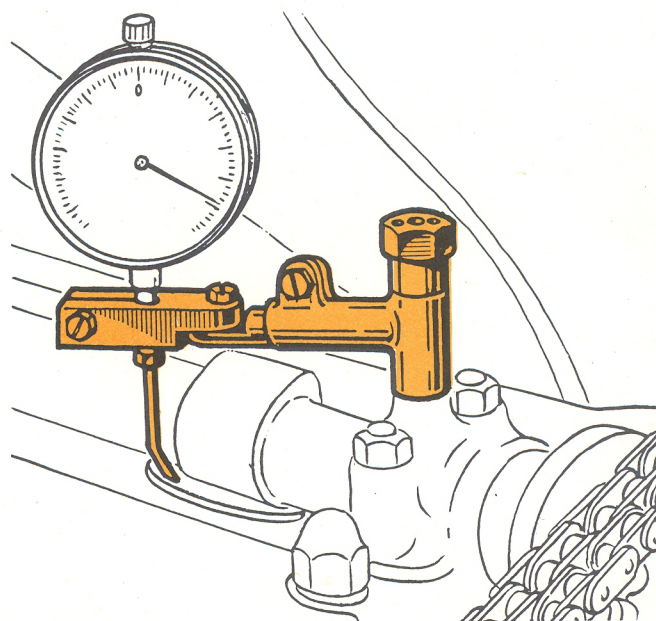
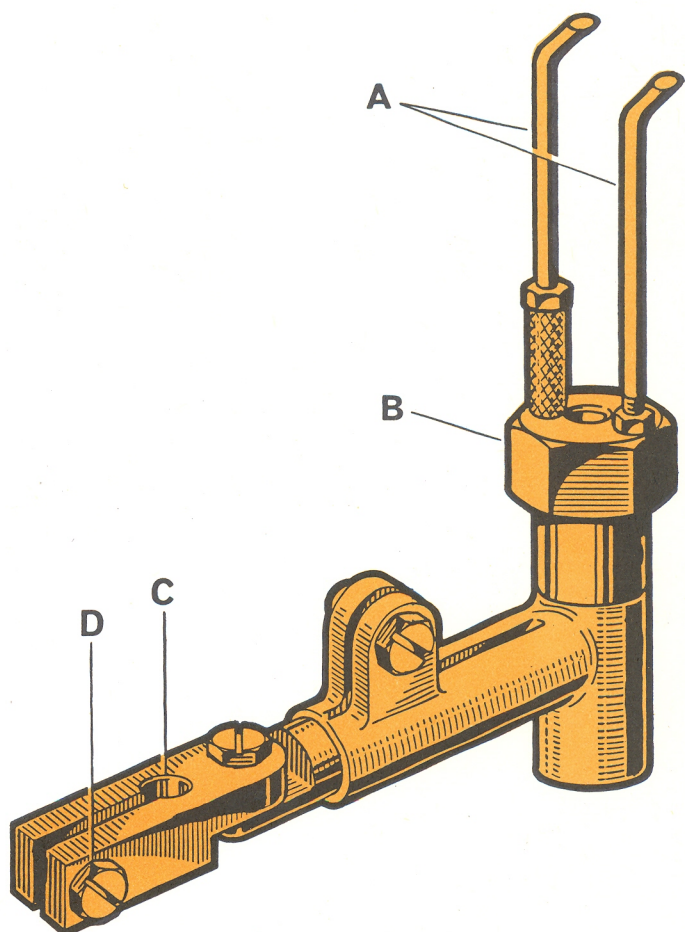

Deletes and supersedes I.B.  
No. 78 dated 19/5/1962

GENERAL TOOLS

SPECIAL TOOLS

X

MACHINERY

EQUIPMENT

MISCELLANEOUS

# Alfa Romeo

DIREZIONE ASSISTENZA CLIENTI

DATE

5-7-1962

SEQUENT NUMBER

79

1600 2000

2600

## Tooling News

### INSERTION OF OIL SEAL RING IN THE TUBES OF REAR AXLE

- 1 Insert the oil seal onto ring "A" of the tool in the appropriate manner.

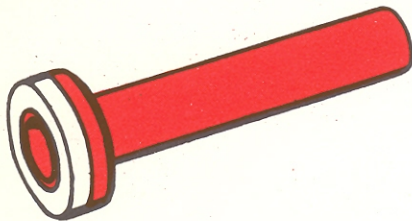

- 2 Effect the setting of the oil seal in its seat by striking upon the end "B" of the tool with a mallet. Be careful not to damage the outside diameter of the oil seal ring.

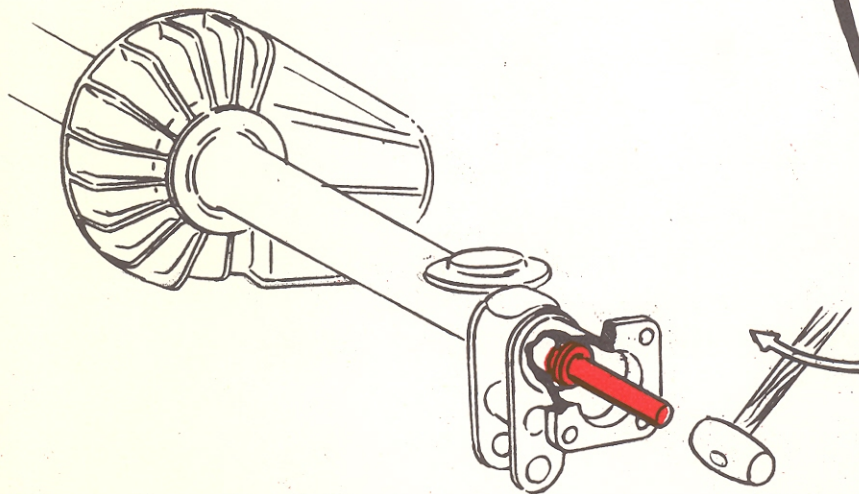

**A. 3.0141**  
2000 2600

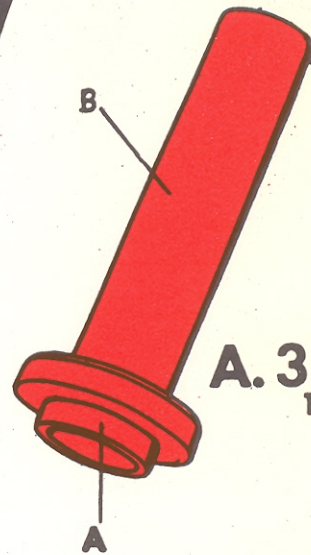

**A. 3.0160**  
1600

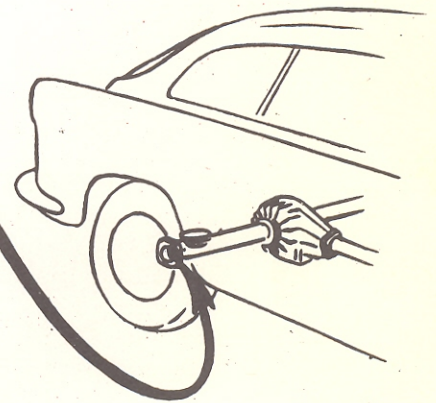

GENERAL TOOLS	
SPECIAL TOOLS	X
MACHINERY	
EQUIPMENT	
MISCELLANEOUS	

# Alfa Romeo

DIREZIONE ASSISTENZA

## Tool Bulletin

DATE

20-5-1964

SEQUENT NUMBER

79/1

**Giulietta - Giulia  
2000 - 2600**

### DRIVING THE OIL SEAL PACKINGS INTO REAR AXLE TUBES

Properly position the oil seal packing out the abutment "A" of the tool.



Drive the oil seal packing into its seat by tapping with a mallet on the end "B" of the tool. Take care not to damage the outer rim of the oil seal.

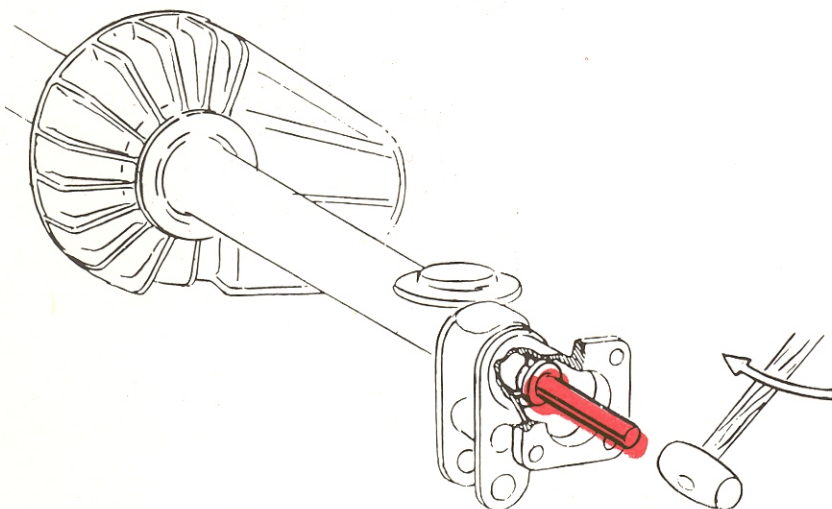

**A.3.0141**

2000 - 2600

**A.3.0160**

Giulia

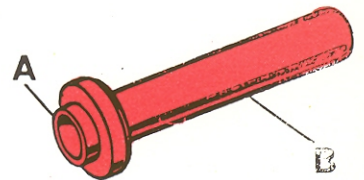

**A.3.0186**

Giulietta

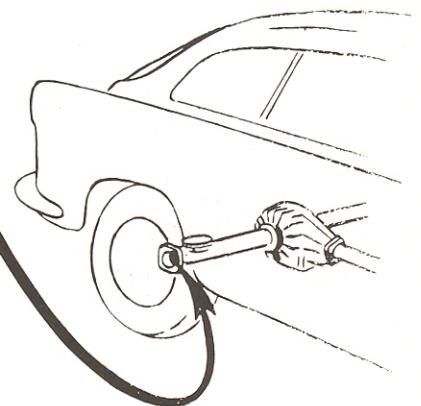
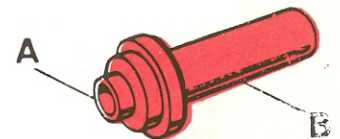

GENERAL TOOLS	
SPECIAL TOOLS	X
MACHINERY	
EQUIPMENT	
MISCELLANEOUS	

# Alfa Romeo

DIREZIONE ASSISTENZA

## Tool Bulletin

DATE

27-4-1973

SEQUENT NUMBER

79/2

Giulia - 1750  
2000 - Montreal

### FITTING THE OIL SEAL PACKINGS INTO REAR AXLE TUBES

**A.3.0160**

Giulia - 1750

**A.3.0274**

2000 - Montreal

**1** Thoroughly clean the seat of the seals to prevent damaging it on fitment.

**2** Place the seal in position on tool end "A".

**3** Fit the oil seal into its seat by tapping with a mallet on the end "B" of the tool.

To avoid damaging the outer rim of the oil seal while fitting it, the tool must be kept aligned as close as possible with the tube centreline. See fig. 2.

**4** On completion of seal fitment, special attention must be paid in removing the tool to avoid damage to the sealing edge of the seals.

Fig. 1

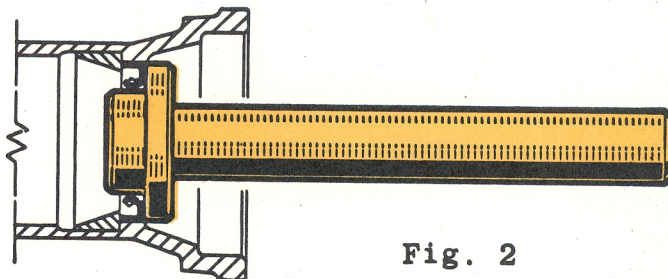
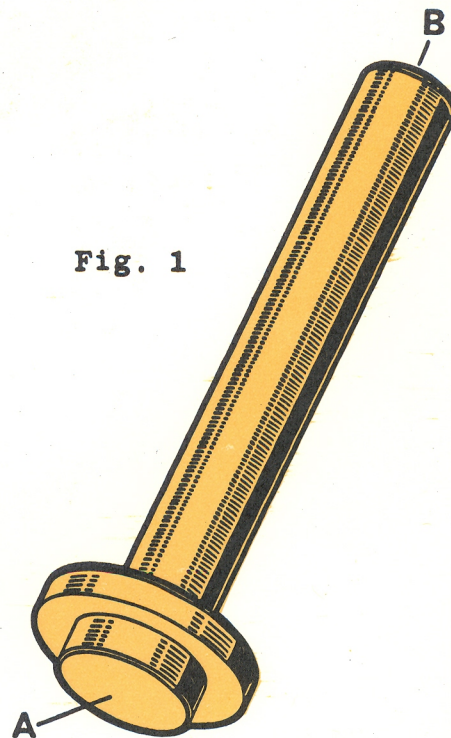

Fig. 2

Deletes and supersedes I.B.  
No. 79/1 dated 20/5/1964

GENERAL TOOLS

SPECIAL TOOLS

X

MACHINERY

EQUIPMENT

MISCELLANEOUS

# Alfa Romeo

DIREZIONE ASSISTENZA CLIENTI

DATE

1-3-1969

SEQUENT NUMBER

80/2

## Tooling News

Giulia - 1750

### DRIVING AND REMOVING THE VALVE GUIDES

### A.3.0246

(intake)

### A.3.0133

(exhaust)

- 1 Driving:  
Withdraw "A" from "B" and put it into the valve guide
- 2 Place the valve guide so prepared into the driver "B"
- 3 Drive the valve guide into its seat by tapping with a mallet

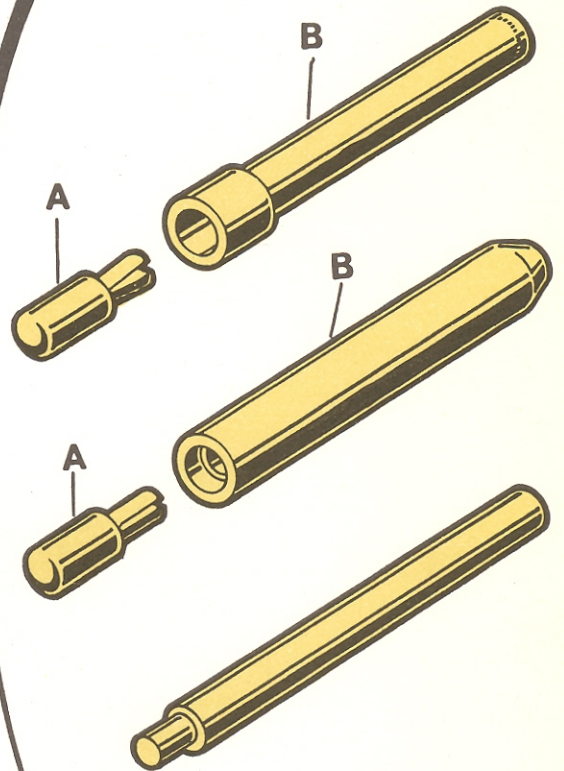
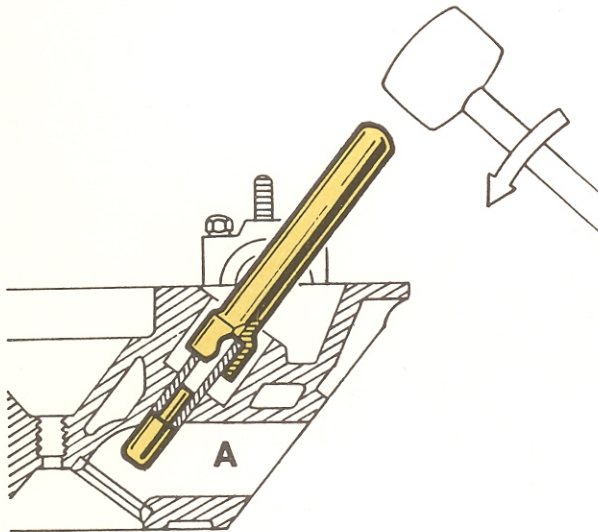

### A.3.0134

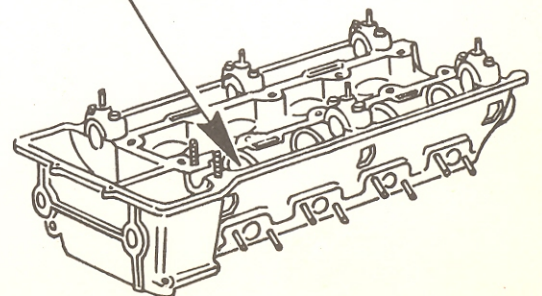

- 4 Removing:  
Insert the punch in the valve guide and remove the guide by tapping with a mallet

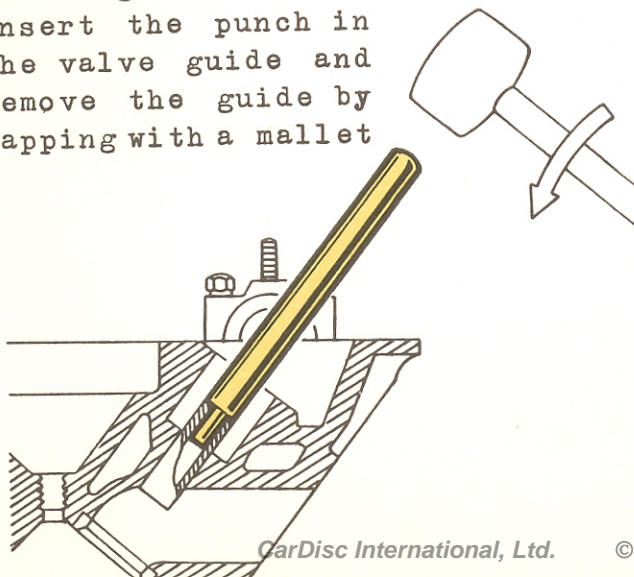

This Bulletin deletes and super-  
sedes I.B. no 80/1 dated 1/6/966

GENERAL TOOLS	
SPECIAL TOOLS	X
MACHINERY	
EQUIPMENT	
MISCELLANEOUS	

# Alfa Romeo

DIREZIONE ASSISTENZA

DATE

27-4-1973

SEQUENT NUMBER

80/4

## Tool Bulletin

Giulia-1750-F 12  
2000 - Montreal  
Alfetta - Alfesud

### WITHDRAWING AND FITTING THE VALVE GUIDES

- 1** WITHDRAWING (fig. 2)  
Insert the tool tip in the valve guide and remove the guide by tapping with a mallet.
- 2** For tools applicability refer to the table below.
- 3** FITMENT (fig. 1)  
Remove the end "A" from the tool "B" and fit it to the valve guide.
- 4** Insert the valve guide so prepared into the bore of tool.
- 5** Drive the valve guide into its seat by tapping with a mallet.

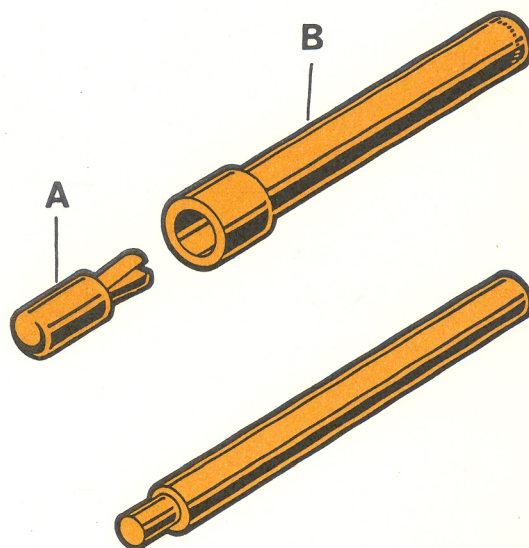

Note - For the withdrawal and fitment procedure refer to the "Shop Manual"

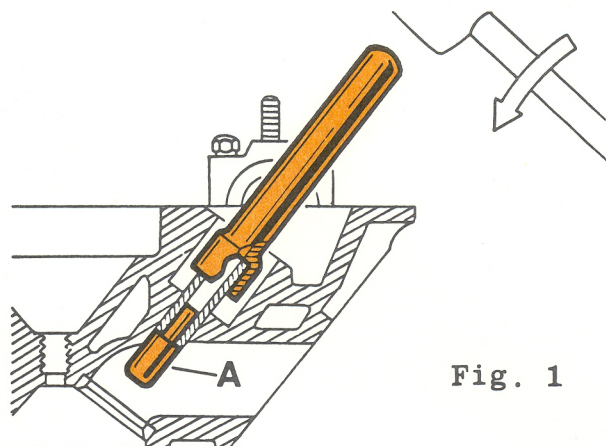

Fig. 1

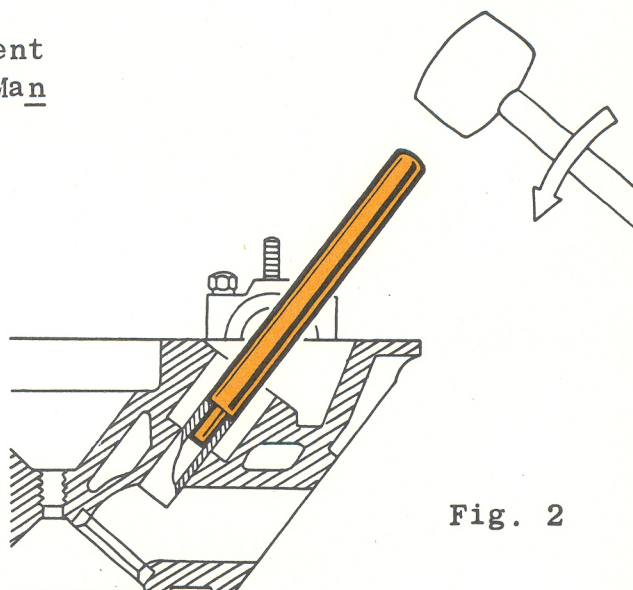

Fig. 2

Vehicles	FITMENT		WITHDRAWAL
	Intake	Exhaust	
GIULIA - 1750 - MONTREAL - ALFETTA - F 12	A.3.0246	A.3.0133	A.3.0134
ALFASUD	A.3.0312	A.3.0313	A.3.0311
2000	A.3.0388	A.3.0389	A.3.0134

Deletes and supersedes I.B.  
No. 80/3 dated 28/2/1973

GENERAL TOOLS

SPECIAL TOOLS

X

MACHINERY

EQUIPMENT

MISCELLANEOUS

# Alfa Romeo

DIREZIONE ASSISTENZA CLIENTI

DATE  
15-1-1964

SEQUENT NUMBER

81/1

GIULIETTA - GIULIA  
2000 - 2600

## Tooling News

### CHECKING THE CYLINDER BARREL I.D.

C.8.0100  
(Giulia - 2600)

C.8.0101  
(2000)

C.8.0102  
(Giulietta)

1

Insert the dial gauge sensing points into the ring gauge and zero set the dial gauge to the ring gauge I.D.

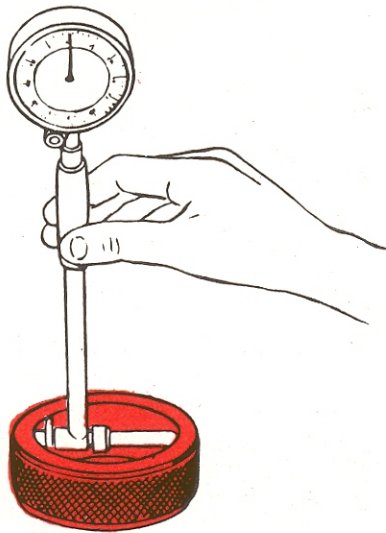

2

With the dial gauge set as per "1" above, take readings of barrel I.D. and note down the possible variations.

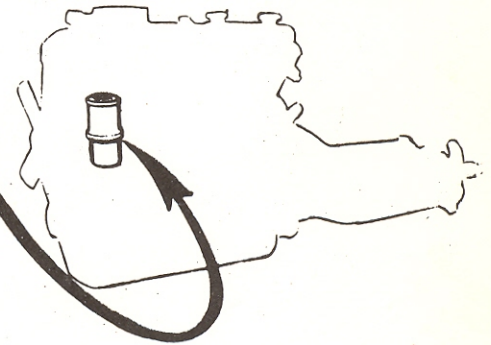
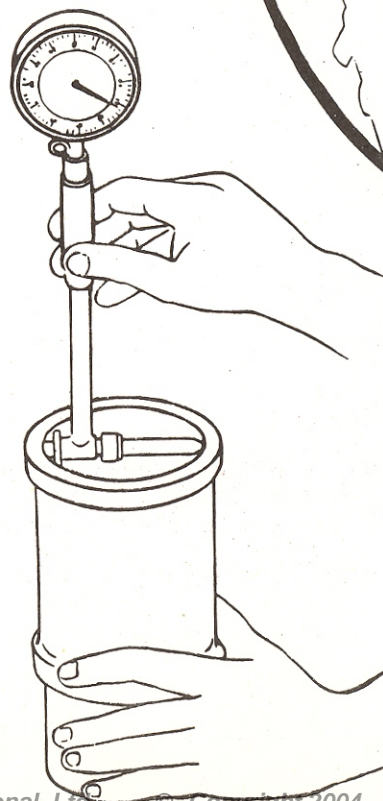

GENERAL TOOLS

SPECIAL TOOLS

X

MACHINERY

EQUIPMENT

MISCELLANEOUS

# Alfa Romeo

DIREZIONE ASSISTENZA

## Tool Bulletin

DATE

28-2-1973

SEQUENT NUMBER

81/2

Giulia-1750-F 12  
2000 - Montreal  
Alfetta - Alfasud

### CHECKING THE CYLINDER BARREL I.D.

C.8.0100  
1600

C.8.0102  
1300

C.8.0104  
Montreal-Alfetta  
1750 - Alfasud

C.8.0106  
2000

**1** Prepare the bore gauge with a stylus suitable to the bore of the cylinder being checked.

**2** Insert the bore gauge into the ring gauge and zero set the dial against the ring gauge I.D.; make certain the stylus is at the middle of its measuring range.

It is recommended to set the bore gauge to zero at the ring gauge reference line, if any.

**3** With the dial gauge set as per "2" above, take readings of barrel I.D. and note down the possible variations.

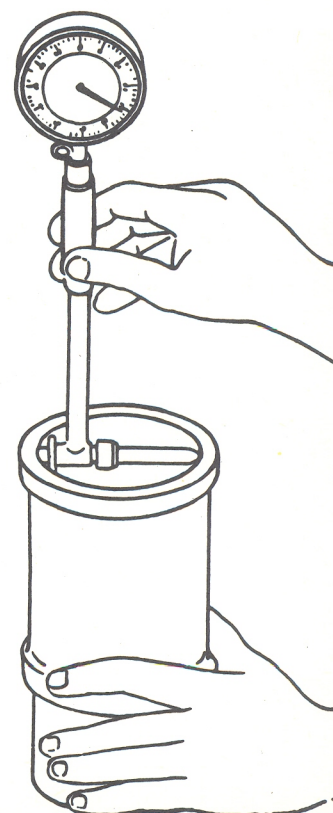
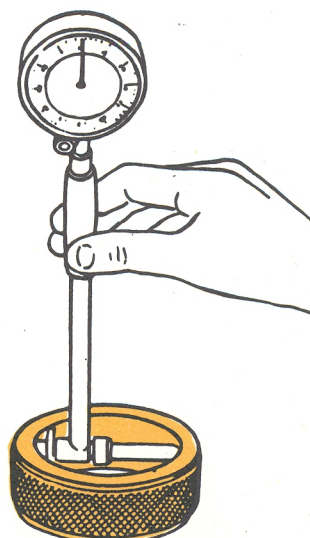

Deletes and supersedes T.B.  
No. 81/1 dated 15/1/1964

GENERAL TOOLS

SPECIAL TOOLS

X

MACHINERY

EQUIPMENT

MISCELLANEOUS

# Alfa Romeo

DIREZIONE ASSISTENZA

DATE

20-5-1964

SEQUENT NUMBER

82/1

## Tool Bulletin

Giulietta - Giulia  
2000 - 2600

### DRIVING THE SLINGER AND THE RETAINER RING ONTO WATER PUMP SHAFT

### A. 3.0137

1

Fit the guide "B" on the shaft unthreaded end; place the retainer ring on the guide and with "C" drive the ring toward the bearing until it seats in the groove.

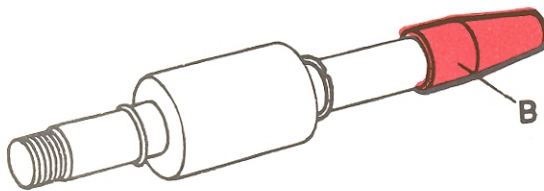

2

Insert the slinger "A" into the tool "C" as shown.

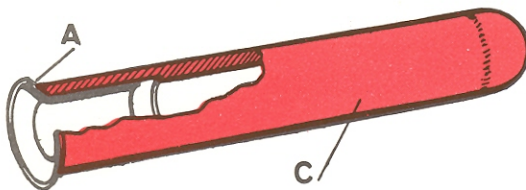

3

Drive the slinger "A" onto water pump shaft until the slinger contacts the retainer ring.

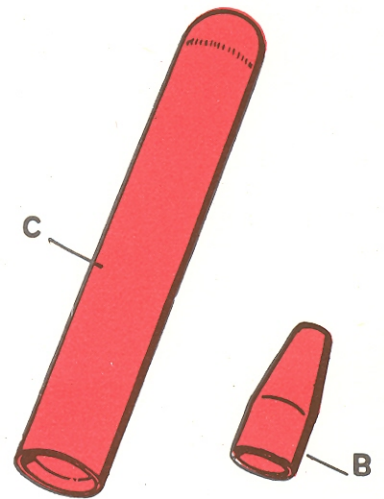
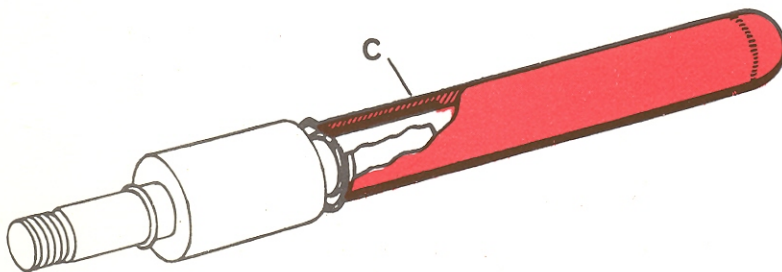

### A. 3.0155

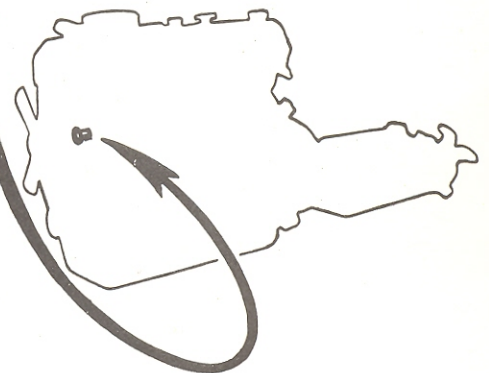

GENERAL TOOLS	
SPECIAL TOOLS	X
MACHINERY	
EQUIPMENT	
MISCELLANEOUS	

# Alfa Romeo

DIREZIONE ASSISTENZA

DATE  
19-5-1962

SEQUENT NUMBER

83

## Tool Bulletin

GIULIETTA 2000  
2600 1600

### PULLING THE WATER PUMP IMPELLER OUT OF THE SHAFT

### A. 3.0136

- 1 Place the two half-rings "A" in such a way as to clasp the impeller hub.

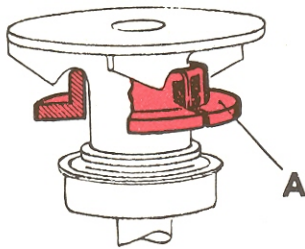

- 2 Insert the impeller & shaft assembly so arranged in the tool bore and push down the shaft with a hand press.

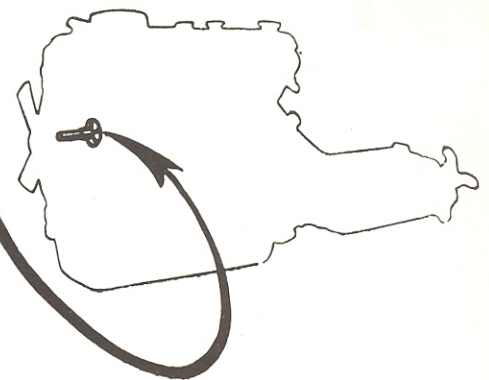
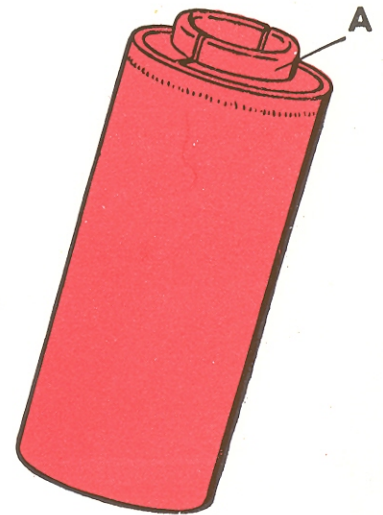
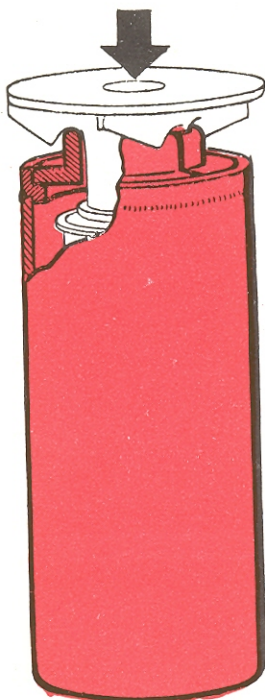

GENERAL TOOLS	
SPECIAL TOOLS	X
MACHINERY	
EQUIPMENT	
MISCELLANEOUS	

# Alfa Romeo

DIREZIONE ASSISTENZA

DATE  
30-4-1962

SEQUENT NUMBER  
84

## Tool Bulletin

# 2600

### DRIVING THE CRANKSHAFT SEAL PACKING INTO THE FRONT COVER

A. 3.0138

- 1 Properly position the oil seal packing onto the abutment "A" of the tool.

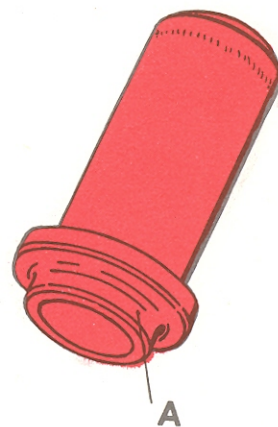
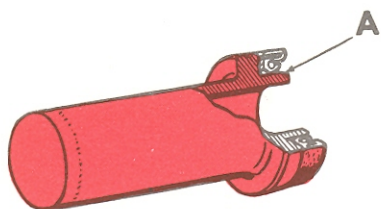

- 2 Center the tool on crankshaft and drive the oil seal packing into its seat in the front cover.

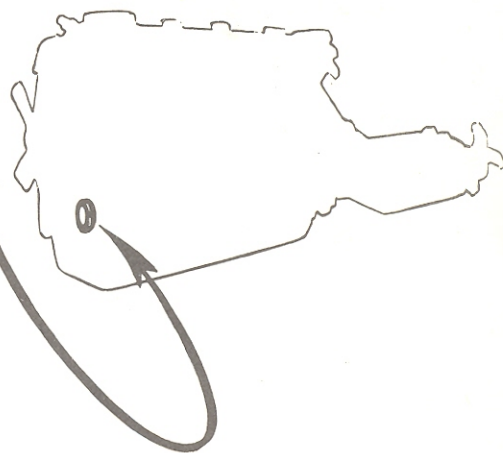
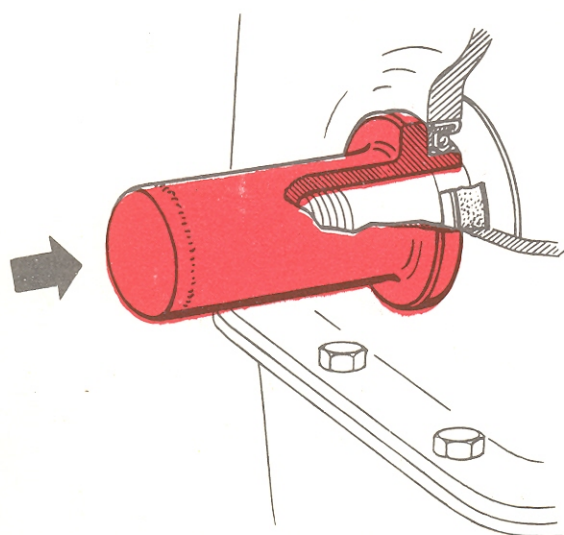

GENERAL TOOLS

SPECIAL TOOLS

X

MACHINERY

EQUIPMENT

MISCELLANEOUS

# Alfa Romeo

DIREZIONE ASSISTENZA CLIENTI

DATE

15-1-1964

SEQUENT NUMBER

85/1

## Tooling News

2600

### INSTALLATION OF REAR CRANKSHAFT OIL SEAL RING

### A. 3.0140

**1** Fit the ring "A" onto the flywheel mounting flange.

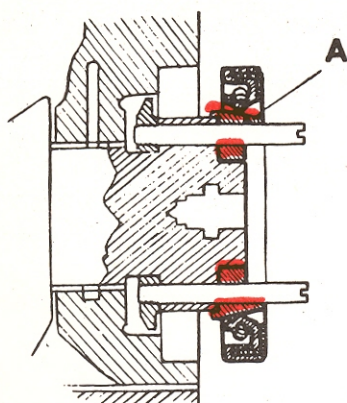

**2** Lead the proper side of oil seal ring onto the ring "A".

**3** Press the oil seal ring into its seat by causing the seal ring itself to override the ring "A"; then push the oil seal ring full home with the driver "B"

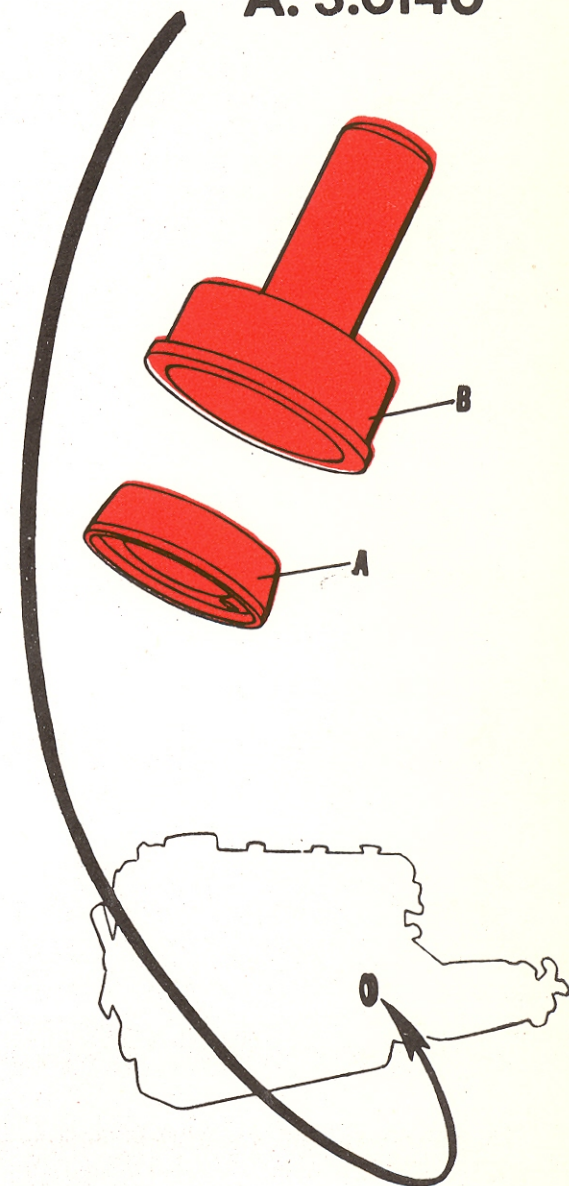
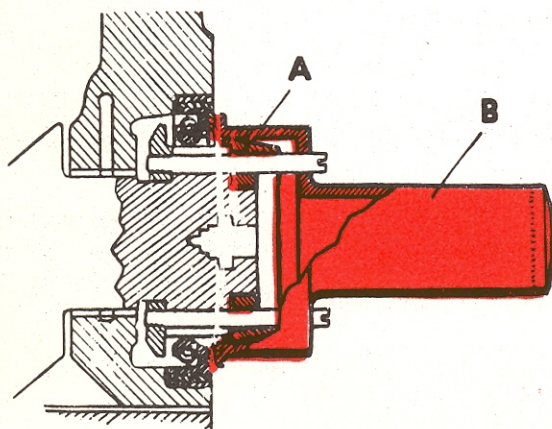

GENERAL TOOLS

SPECIAL TOOLS

X

MACHINERY

EQUIPMENT

MISCELLANEOUS

# Alfa Romeo

DIREZIONE ASSISTENZA CLIENTI

DATE

5-7-1962

SEQUENT NUMBER

86

GIULIETTA

2600 1600

## Tooling News

### EXTRACTION OF BUSHING OF INTERMEDIATE TIMING GEAR FROM THE CRANKCASE

### A. 3.0143

1

Insert expansion pincer (bushing puller) "A" into bushing until it reaches ledge of crankcase

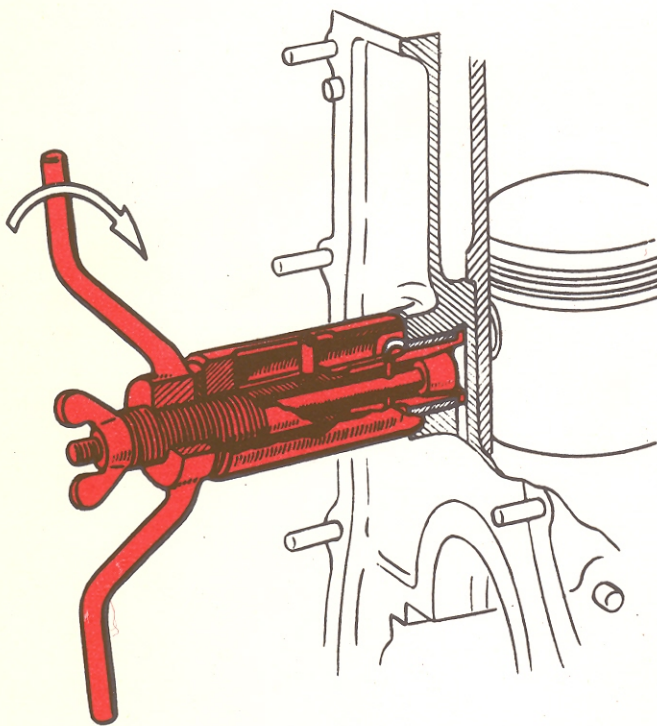

2

Holding handle "D" in a stationary position, turn nut "C" until claws "B" are expanded to the maximum

3

Rotate handle "D" and effect pulling

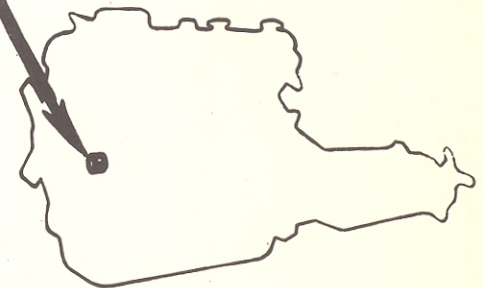
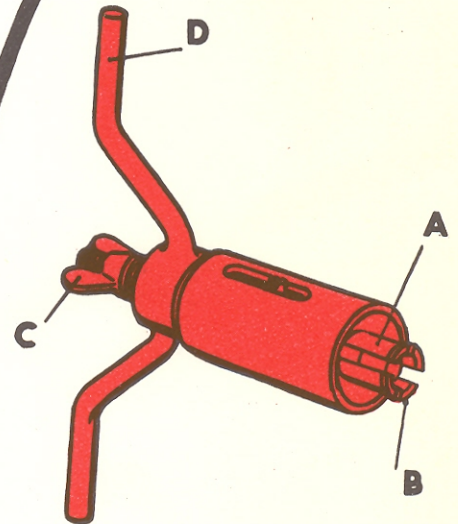

GENERAL TOOLS	
SPECIAL TOOLS	X
MACHINERY	
EQUIPMENT	
MISCELLANEOUS	

# Alfa Romeo

DIREZIONE ASSISTENZA CLIENTI

DATE  
15-1-1964

SEQUENT NUMBER  
86/1

GIULIETTA - GIULIA  
2600

## Tooling News

### REMOVAL OF THE IDLER GEAR BUSH FROM CRANKCASE

A. 3.0143

- 1** Insert the puller "A" into the bush until it stops against the shoulder in crankcase.

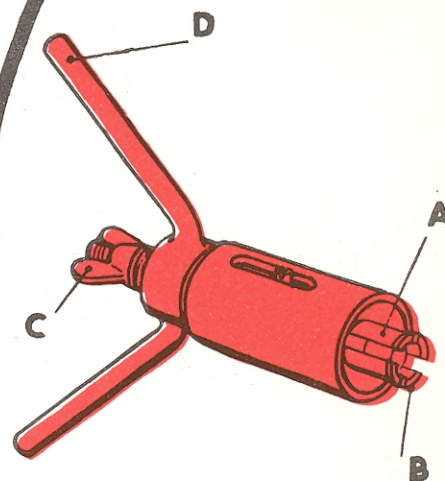
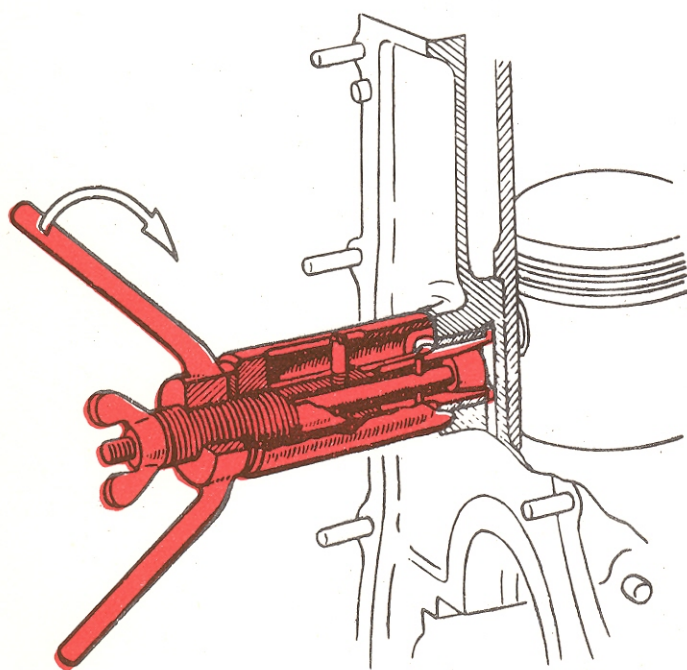

- 2** Holding the handle "D" stationary screw the wingnut "C" until the puller teeth "B" are fully expanded.

- 3** Rotate the handle "D" and withdraw the bushing.

This I.N. deleter and super-  
sedes no. 86 dated 5/7/1962.

GENERAL TOOLS

SPECIAL TOOLS

X

MACHINERY

EQUIPMENT

MISCELLANEOUS

# Alfa Romeo

## DIREZIONE ASSISTENZA CLIENTI

### Tooling News

DATE

5-7-1962

SEQUENT NUMBER

87

GIULIETTA

2600 1600

### DISASSEMBLING CAP OF THE REAR BEARING OF CRANKSHAFT

1

Mount the appropriate extraction fork "B" upon the lever "A".

2

Hook the cap of the rear bearing to the fork and resting the end "C" on the surface of the crankcase make the extraction by pressing up on the end "D".

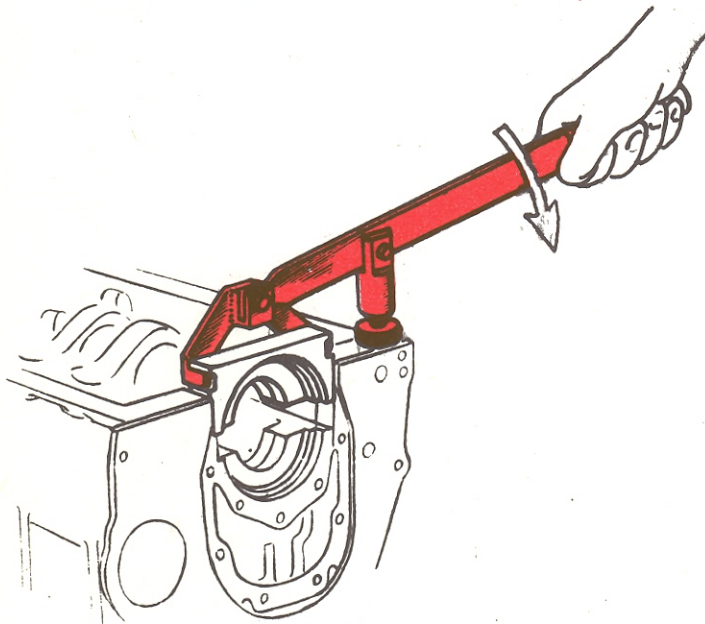

### A.3.0139

(Complete)

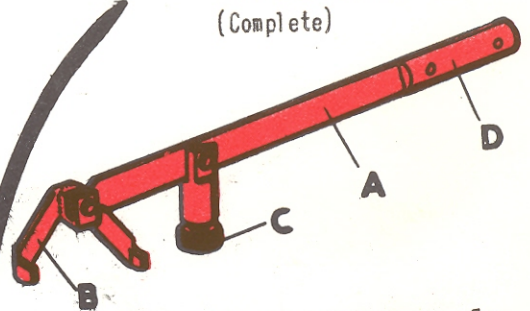

### A.3.0139/1

(For all types)

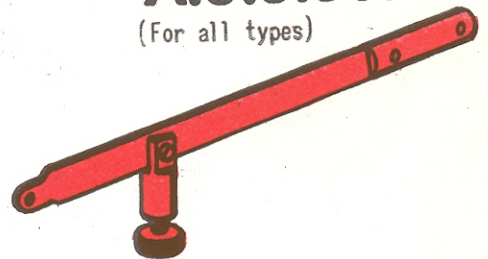

### A.3.0139/2

(101 - 105)



### A.3.0139/3

(106)



N.B. - This sheet replaces and cancels sheet 2.013 issued on July 27, 1957. The existing tool No.61.21.11.006 differs from the present tool A. 3.0139 by the addition of the fork (for 106) A. 3.0139/3.

Translated in February 1963

GENERAL TOOLS	
SPECIAL TOOLS	X
MACHINERY	
EQUIPMENT	
MISCELLANEOUS	

# Alfa Romeo

DIREZIONE ASSISTENZA

## Tool Bulletin

DATE

28-2-1973

SEQUENT NUMBER

87/1

Giulia - 1750  
2000 - Alfetta

### REMOVING THE REAR MAIN BEARING CAP

A.3.0139

1 Fit the fork "B" to the lever "A".

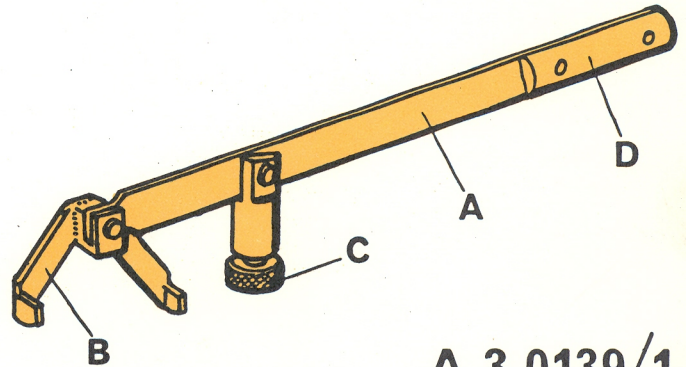

2 Engage the fork in the rear main bearing cap and pry it up by resting the pad "C" on crankcase and lowering the handle "D".

A.3.0139/1

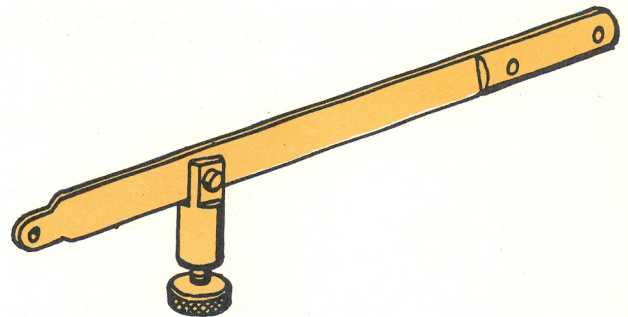

A.3.0139/2

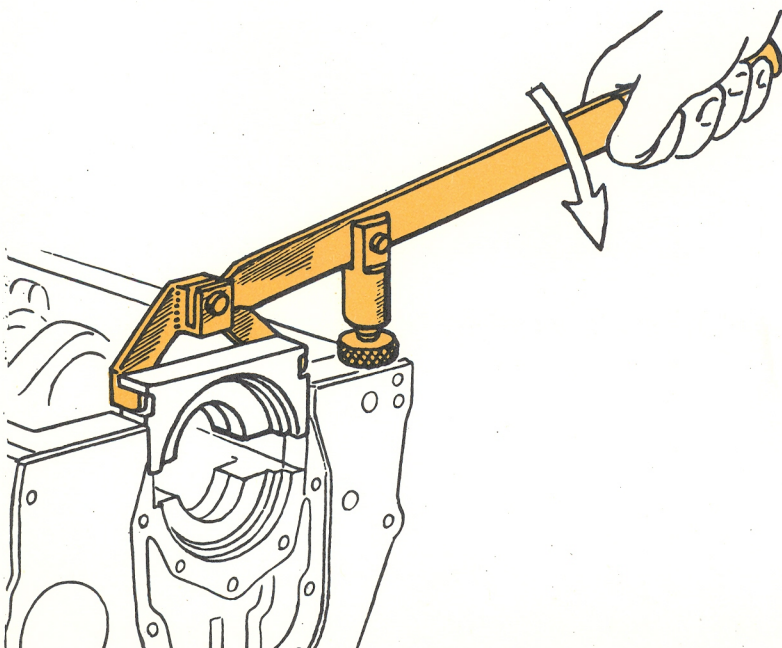
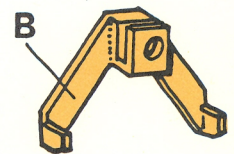

Deletes and supersedes T.B.  
No. 87 dated 5/7/1962

GENERAL TOOLS

SPECIAL TOOLS

X

MACHINERY

EQUIPMENT

MISCELLANEOUS

# Alfa Romeo

## DIREZIONE ASSISTENZA CLIENTI

### Tooling News

DATE

5-7-1962

SEQUENT NUMBER

88

GIULIETTA

2600 1600

### LOCKING OF VALVES IN ORDER TO REMOVE THE HALFCONES

### A. 2.0121

1 Unscrew nut "A" and un-thread spacer "B".

2 Mount tool on cylinder head letting shank "D" pass through the hole of the spark plug and position the block "E" so that the surfaces "C" adhere to the two valves.

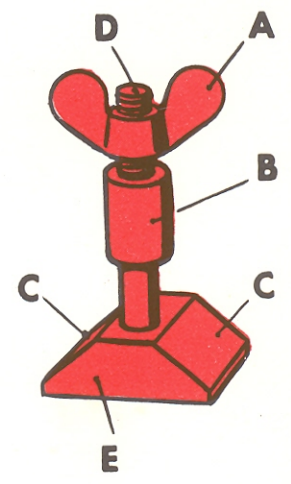
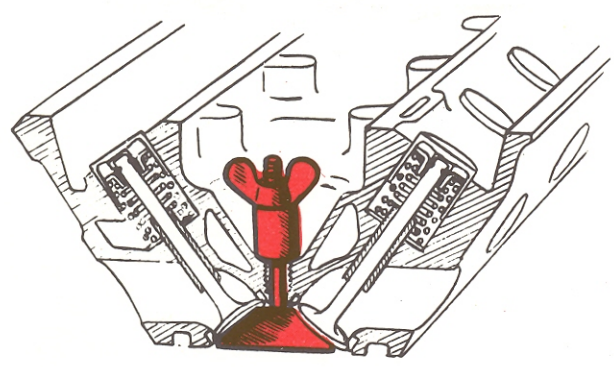

3 Apply spacer "B" on the outside of the cylinder head on the holding plane of the spark plugs and tighten nut "A".

4 Proceed with the disassembling of the halfcones

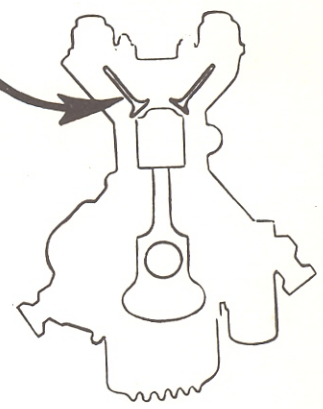
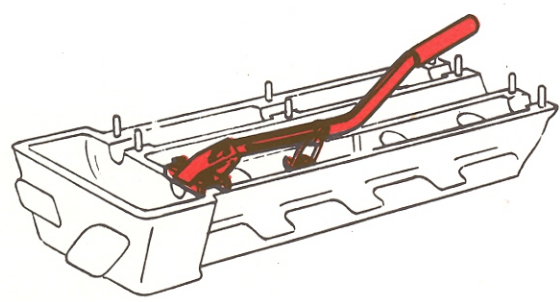

GENERAL TOOLS

SPECIAL TOOLS

X

MACHINERY

EQUIPMENT

MISCELLANEOUS

# Alfa Romeo

## DIREZIONE ASSISTENZA CLIENTI

### Tooling News

DATE

5-7-1962

SEQUENT NUMBER

89

GIULIETTA  
2000  
1600 2600

### EXTRACTION OF FAN PULLEY

## A.3.0147

- 1 Slacken the transmission belt and remove fan.

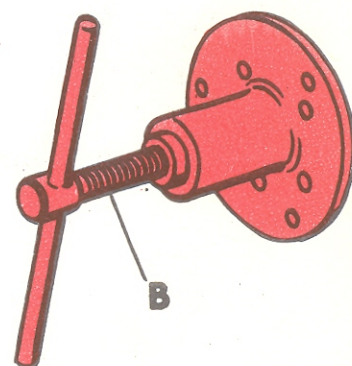
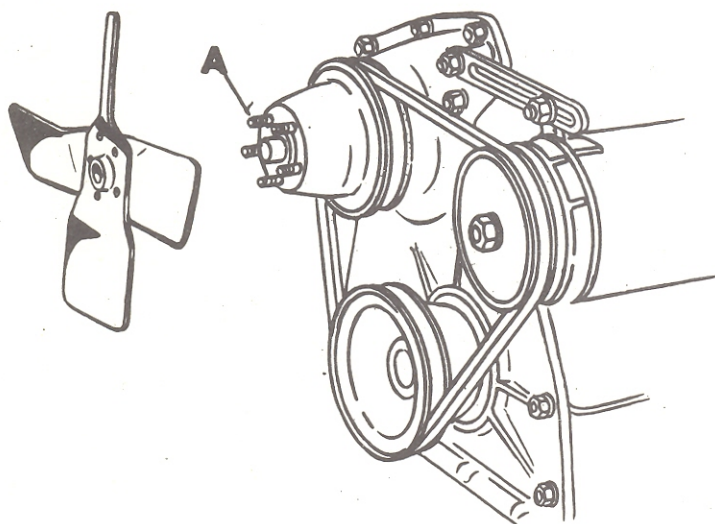

- 2 Mount the tool and fasten upon the pulley utilizing the holes that coincide with the screws "A" which secure the fan.

- 3 Turn until the end of screw "B" contacts the shaft of the water pump and then effect extraction.

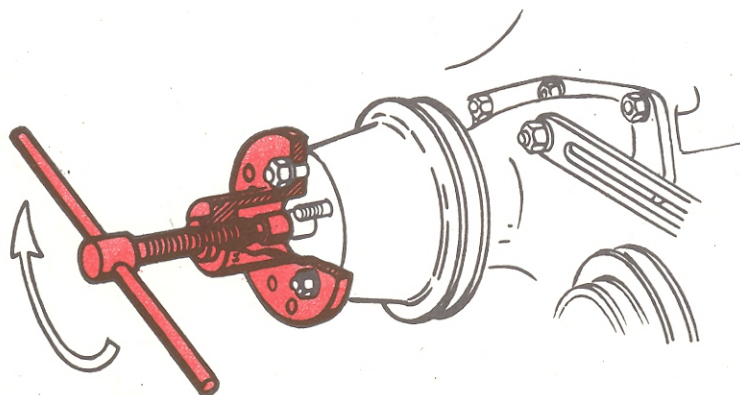

Translated in February 1963

GENERAL TOOLS

SPECIAL TOOLS

X

MACHINERY

EQUIPMENT

MISCELLANEOUS

*Alfa Romeo*

DIREZIONE ASSISTENZA

## Tool Bulletin

DATE

28-2-1973

SEQUENT NUMBER

89/1

Giulia - 1750  
2000 - Alfetta  
F 12

A.3.0147

### FAN PULLEY WITHDRAWAL

- 1 The withdrawal of fan pulley should be performed with the engine on bench.

Slacken the drive belt and remove the fan.

- 2 Fit the tool to the pulley by using the fan mounting studs "A" protruding from the holes in the tool flange.

- 3 Bring the end of screw "B" at rest against the water pump spindle and withdraw the pulley.

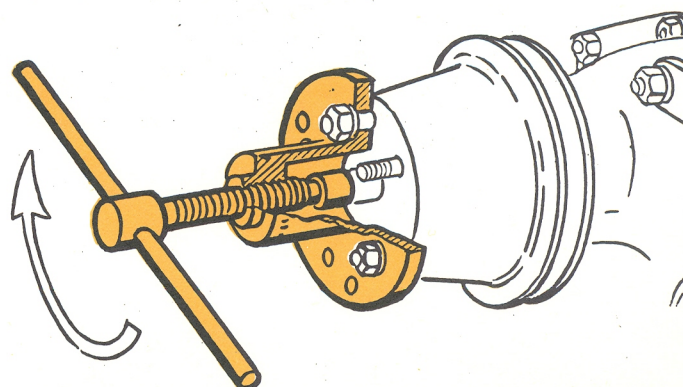
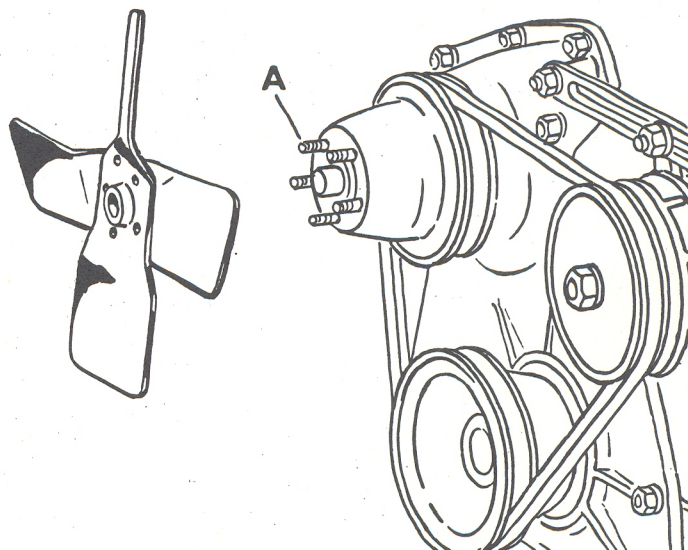
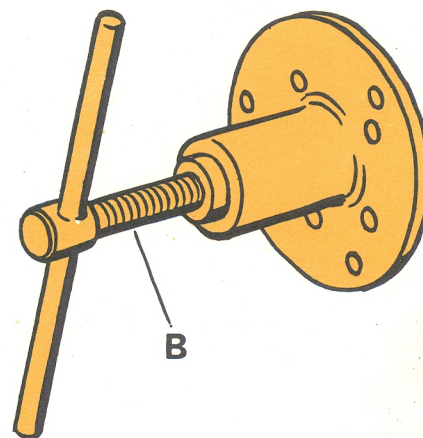

Deletes and supersedes T.B.  
No. 89 dated 5/7/1962

GENERAL TOOLS

SPECIAL TOOLS

X

MACHINERY

EQUIPMENT

MISCELLANEOUS

# Alfa Romeo

DIREZIONE ASSISTENZA CLIENTI

DATE

5-7-1962

SEQUENT NUMBER

90

## Tooling News

2000

2600

### CHECKING OF POSITION OF DIFFERENTIAL PINION

### C.6.0113

1

Prepare the following tools:

- 6123.41.111
- C.6.0101
- a comparator

2

Set the tool so that the rings "A" of the two sockets will occupy the seats of the bearings of the differential carrier support. Tighten the nuts securing the caps according to torque indicated in the shop manual. The grooves "B" must coincide exactly edge to edge with the ends of the bearing seats.

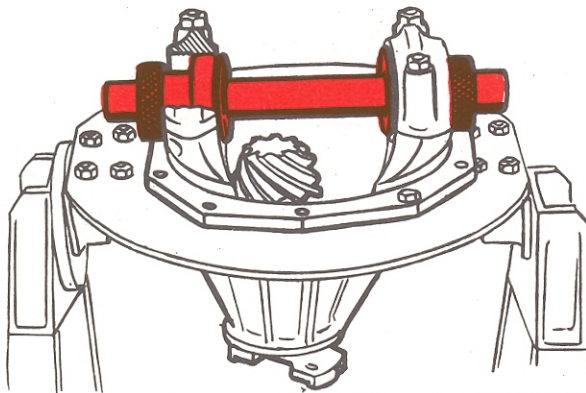

3

Mount a centesimal comparator on the support 6123.41.111 and set it at zero using tool C.6.0101.

4

Rest the base of the comparator holder upon the head of the bevel pinion and effect inspection.

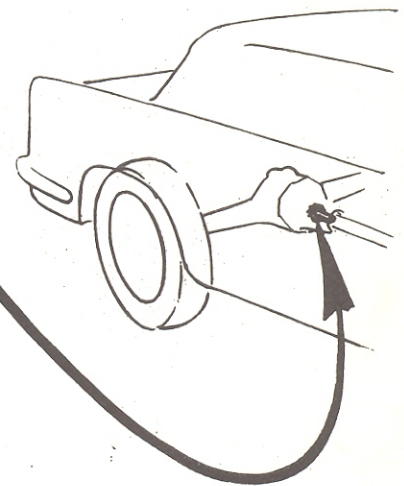
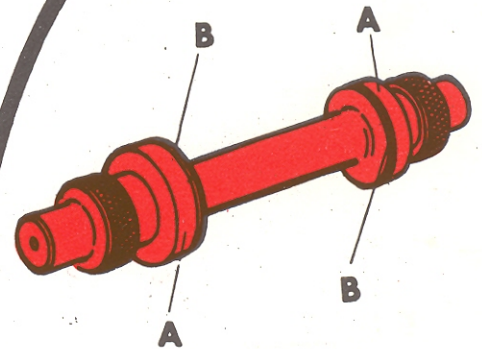
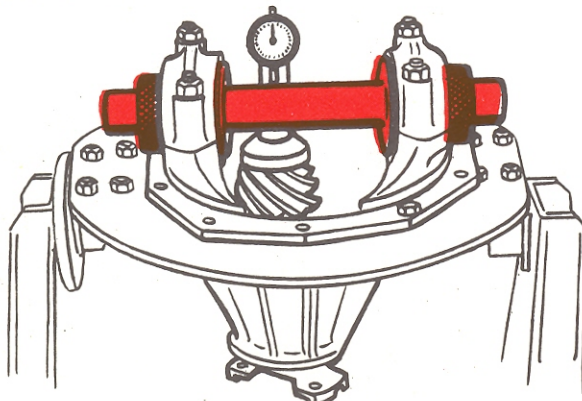

N.B. - It replaces tool 6123.27.108 which is to be held as yet usable.

Translated in March 1963

GENERAL TOOLS

SPECIAL TOOLS

X

MACHINERY

EQUIPMENT

MISCELLANEOUS

**Alfa Romeo**  
DIREZIONE ASSISTENZA CLIENTI

DATE

30-6-1965

SEQUENT NUMBER

90/1

*Tooling News*

2000 - 2600

### CHECKING THE POSITION OF FINAL DRIVE PINION

**C.6.0113**

- 1 Prepare the following tools:
  - C.5.0116
  - C.6.0101
  - a dial gauge

- 2 Set the tool so that the rings "A" of the two sockets will occupy the seats of bearings of differential carrier. Tighten the nuts securing the caps according to torque specified in the shop manual. The grooves "B" must coincide exactly edge to edge with the ends of the bearing seats.

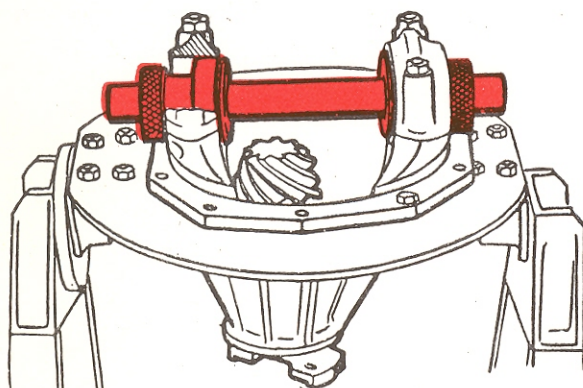

- 3 Mount a dial gauge on the support C.5.0116 and set it at zero using tool C.6.0101.
- 4 Rest the base of the dial gauge on the head of the pinion and check the position.

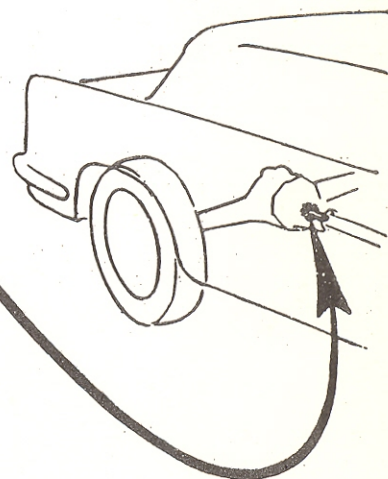
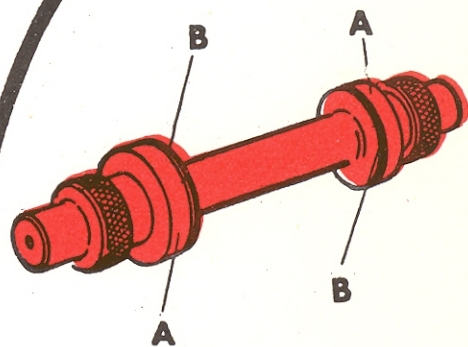
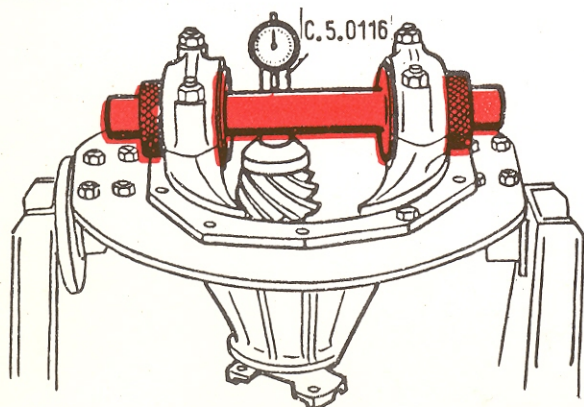

This T.N. deletes and super-  
sedes no. 90 dated 5/7/1962.

GENERAL TOOLS	
SPECIAL TOOLS	X
MACHINERY	
EQUIPMENT	
MISCELLANEOUS	

# Alfa Romeo

DIREZIONE ASSISTENZA

DATE

20-5-1964

SEQUENT NUMBER

91/1

## Tool Bulletin

**Giulietta**

### PULLING THE BALLS OUT OF SOCKET JOINTS

#### Giulietta reaction triangle:

- 1 Move aside, as far as necessary, the brake fluid tubing which corresponds with the pin.
- 2 Insert the tool onto the ball joint between the rubber dust cover and attachment to axle.  
In order to avoid damaging the gasoline tank employ a round aluminum rod which is to be centered on the hole "A" in the tool. Give a few strokes until you are sure that the fork "B" encircles the pin.

**A.3.0154**

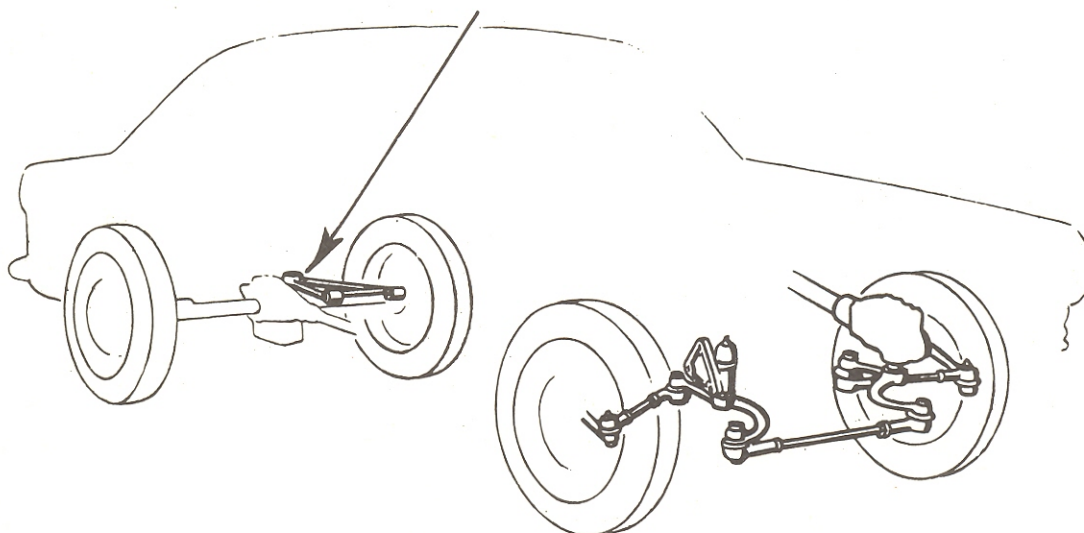
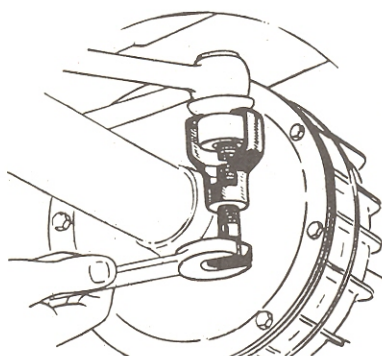
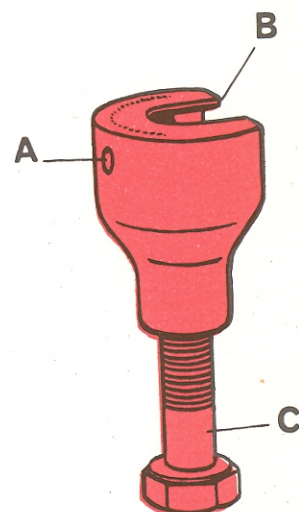

- 3 Turn the screw "C" until the reaction triangle is detached from the axle.

This Bulletin deletes and supercedes T.N. no 91 dated 5/7/1962.

GENERAL TOOLS	
SPECIAL TOOLS	X
MACHINERY	
EQUIPMENT	
MISCELLANEOUS	

# Alfa Romeo

DIREZIONE ASSISTENZA

## Tool Bulletin

DATE

20-5-1964

SEQUENT NUMBER

91/1

**Giulietta**

### PULLING THE BALLS OUT OF SOCKET JOINTS

#### Giulietta reaction triangle:

- 1 Move aside, as far as necessary, the brake fluid tubing which corresponds with the pin.
- 2 Insert the tool onto the ball joint between the rubber dust cover and attachment to axle.  
In order to avoid damaging the gasoline tank employ a round aluminum rod which is to be centered on the hole "A" in the tool. Give a few strokes until you are sure that the fork "B" encircles the pin.

**A.3.0154**

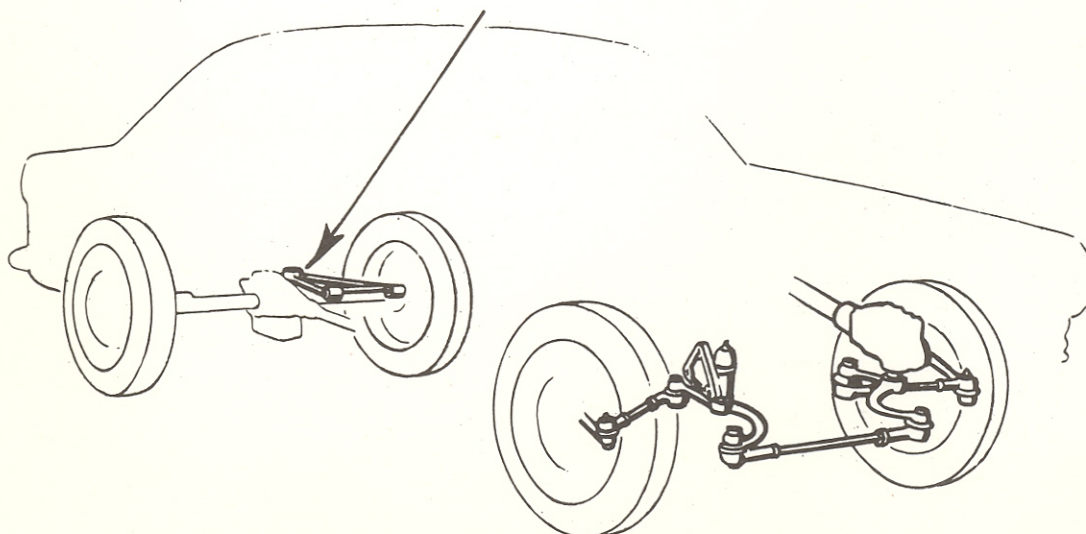
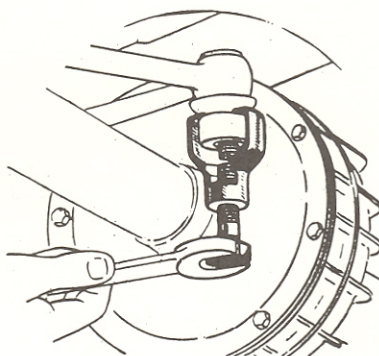
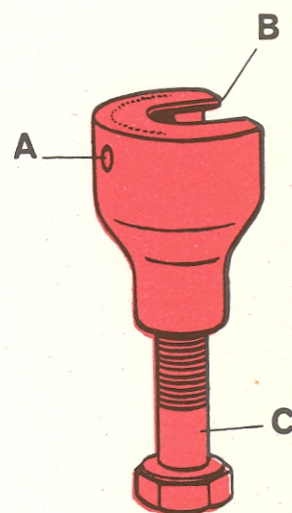

- 3 Turn the screw "C" until the reaction triangle is detached from the axle.

This Bulletin deletes and supercedes T.N. no 91 dated 5/7/1962.

GENERAL TOOLS	
SPECIAL TOOLS	X
MACHINERY	
EQUIPMENT	
MISCELLANEOUS	

*Tool Bulletin*

PULLING THE BEARING CONE  
OUT OF FINAL DRIVE PINION SHAFT

A.3.0150

- 1 Fit half-rings "A" around pinion as shown, making sure the rings are of the proper type (see marking stamped on the rings).

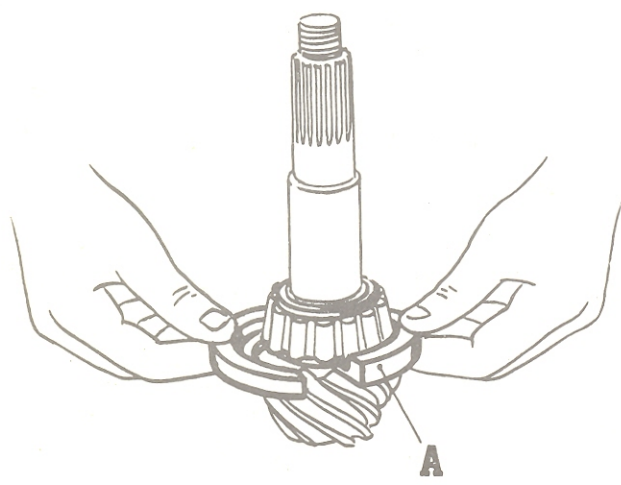

- 2 Rest the pinion assembly so arranged against the base "C". With a hand press act as shown by arrow to pull "B" out of the pinion shaft.

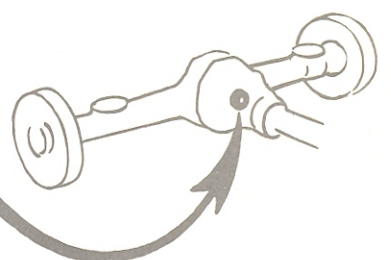
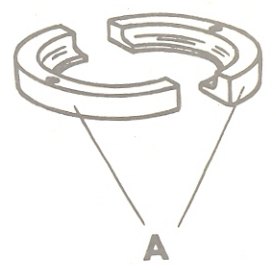
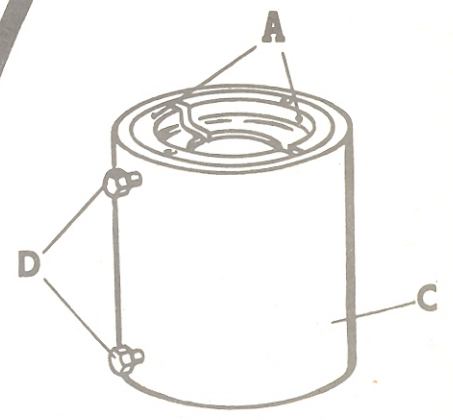
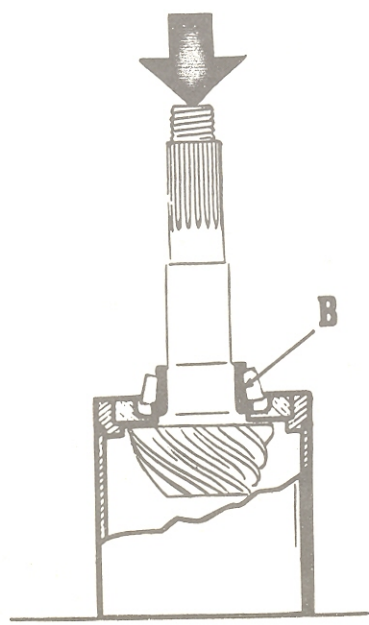

N.B. - When the tool is not in use, hold the half-rings in place with the setscrews "D".

GENERAL TOOLS	
SPECIAL TOOLS	X
MACHINERY	
EQUIPMENT	
MISCELLANEOUS	

# Alfa Romeo

DIREZIONE ASSISTENZA

## Tool Bulletin

DATE	26-2-1973
SEQUENT NUMBER	93/2
Giulia - 1750 2000 - Montreal	

### REMOVAL AND REINSTALLATION OF FRONT SUSPENSION SPRING

A.2.0169

- 1 Remove the screws "A" diametrically opposite as shown.
- 2 Install the tool so that the holes in lugs "B" are aligned with those of the screws previously removed.
- 3 Rotate the column "C" to position the plate "D" suitably against the suspension spring seat "E".
- 4 Mount the longer tie-rods "H" and tighten them with nuts "X".
- 5 Lock the column "C", remove the two screws "M" and mount the shorter tie-rods "O" complete with their nuts "P" as shown in fig.2.
- 6 Rotate the column "C" to lower the plate "D" together with the seat "E" until the spring is fully released.
- 7 To reinstall the spring reverse the procedure of removal.

N.B. - For removing the spring at the L.H. wheel apply the tool the same way as for the right hand spring, not symmetrically.

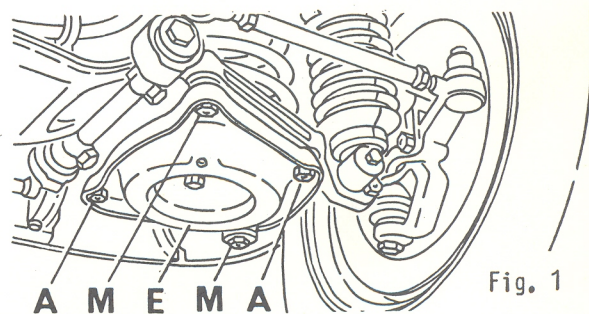
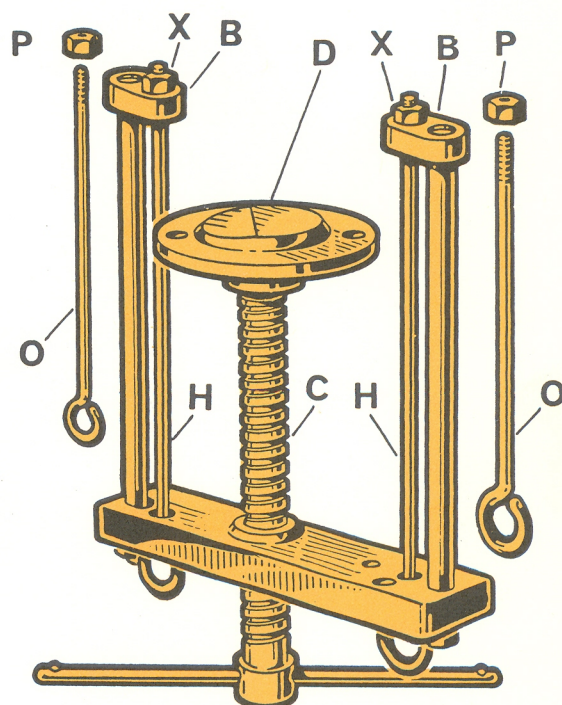

Fig. 1

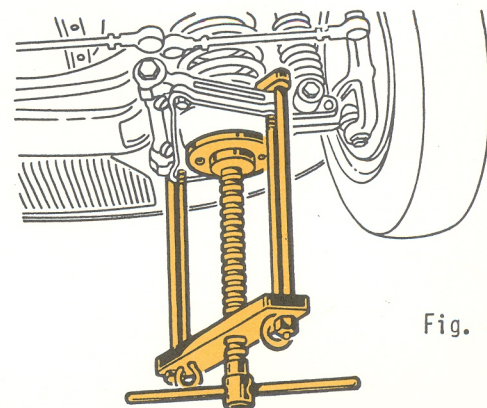

Fig. 2

Deletes and supersedes T.B.  
No. 93/1 dated 18/3/1969

GENERAL TOOLS	
SPECIAL TOOLS	X
MACHINERY	
EQUIPMENT	
MISCELLANEOUS	

# Alfa Romeo

DIREZIONE ASSISTENZA

DATE

26-2-1973

SEQUENT NUMBER

94/2

Giulia - 1750  
2000 - Alfetta  
2600 - F 12

## Tool Bulletin

### REAMING THE BUSHINGS OF TIMING CHAIN IDLE SPROCKET

- 1 Renew the bushings in the cylinder block and in front cover.
- 2 Fit the front cover to cylinder block.
- 3 Install the guide tool (A.4.0112 for Giulia, Alfetta, 1750 and 2000 models or A.4.0113 for 2600 models) onto the water pump mounting on front cover. Centring occurs about crankshaft end and the protruding part of front bushing.
- 4 Ream the bushings by means of the reamers U.2.0040 for roughing and U.2.0041 for finishing. While reaming, use plenty of lubricant, a slow rate of feed and a suitable hand tap wrench. Make sure the finishing reamer is fed until it stops against the bottom of dead hole in cylinder block.
- 5 Remove the guide tool and check for proper diameter and alignment of bores with the gauge C.8.0103 ("go" end).
- 6 Remove the front cover and check for proper diameter of bushings with the gauge C.8.0103 ("not go" end).

A.4.0112

Giulia - 1750 - 2000 - Alfetta

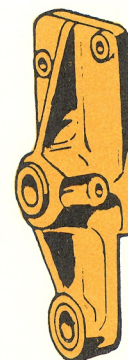

A.4.0113

2600

C.8.0103



U.2.0040



U.2.0041

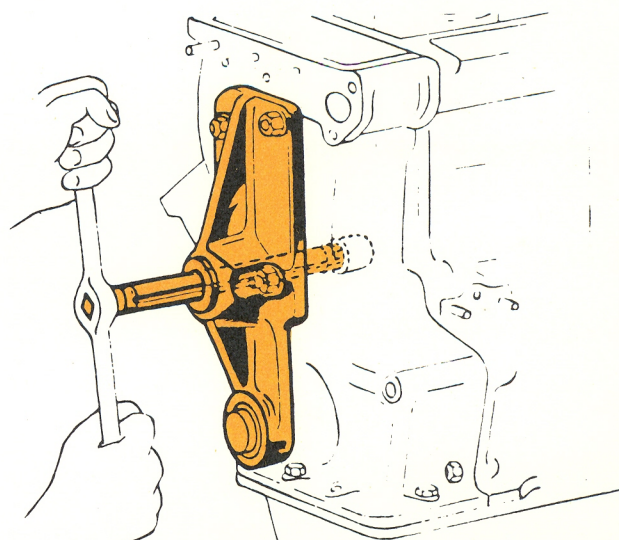
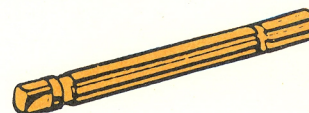

GENERAL TOOLS

SPECIAL TOOLS

MACHINERY

EQUIPMENT

MISCELLANEOUS

# Alfa Romeo

DIREZIONE ASSISTENZA CLIENTI

DATE  
5-7-1962

SEQUENT NUMBER

95

2000 2600

## Tooling News

### INSERTION AND WITHDRAWAL OF DIFFERENTIAL BEARINGS

1

Tool A.3.0151 is used to insert the ring "A" of the rear bearing of pinion and the inside rings "B" of the lateral bearings of the differential carrier.

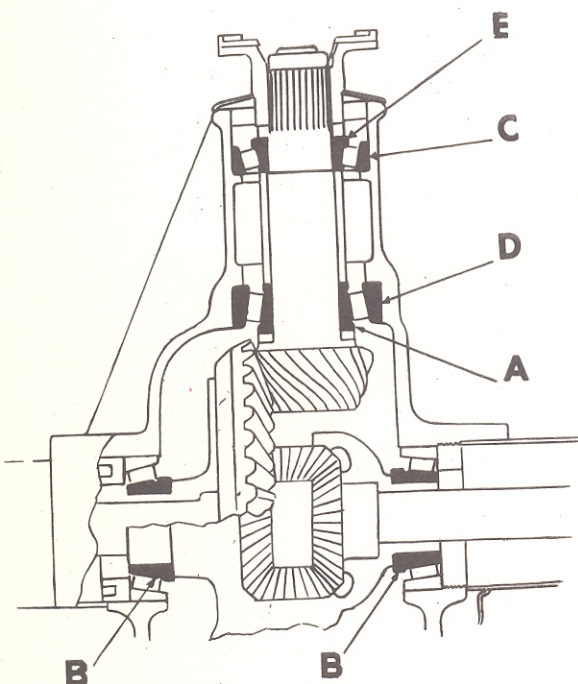

2

Tools A.3.0148 and A.3.0149 are used to withdraw and to insert the outside rings "C" and "D" of the pinion bearings (A.3.0148 for "C" and A.3.0149 for "D")

3

Tool A.3.0152 is used to insert the inside ring "E" of the front bearing of pinion.

### A.3.0151

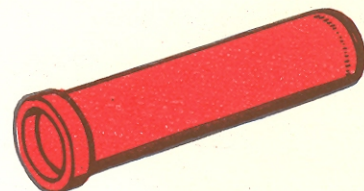

### A.3.0148

### A.3.0149

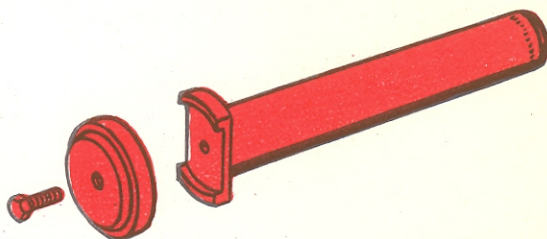

### A.3.0152

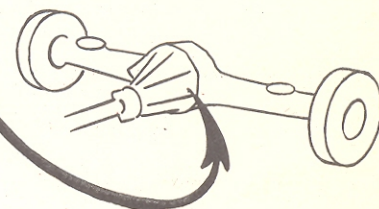
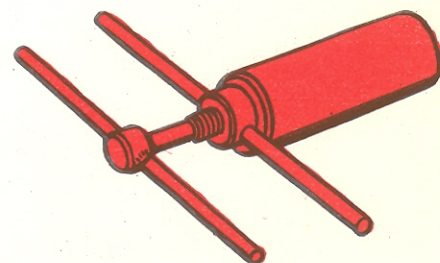

GENERAL TOOLS	
SPECIAL TOOLS	X
MACHINERY	
EQUIPMENT	
MISCELLANEOUS	

# Alfa Romeo

DIREZIONE ASSISTENZA

## Tool Bulletin

DATE  
5-7-1962

SEQUENT NUMBER  
95

2000 2600

### INSERTION AND WITHDRAWAL OF DIFFERENTIAL BEARINGS

- 1 Tool A.3.0151 is used to insert the ring "A" of the rear bearing of pinion and the inside rings "B" of the lateral bearings of the differential carrier.

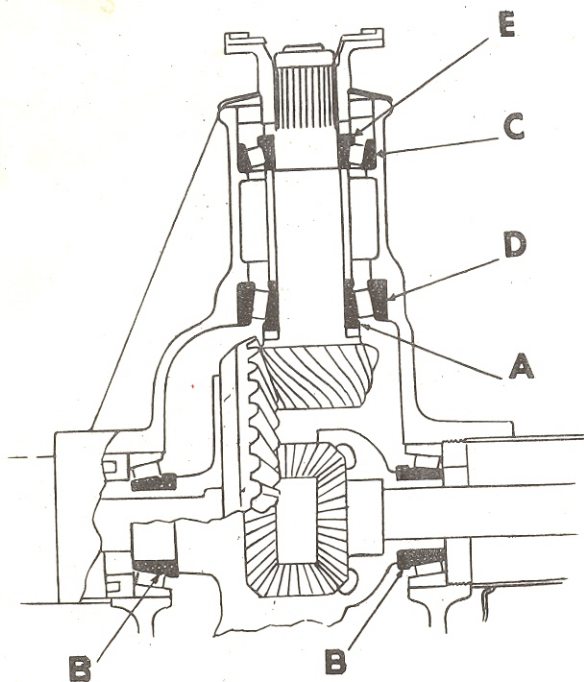

**A.3.0151**

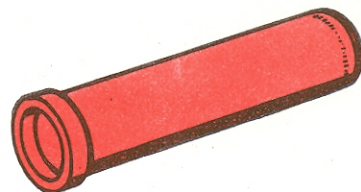

**A.3.0148**

**A.3.0149**

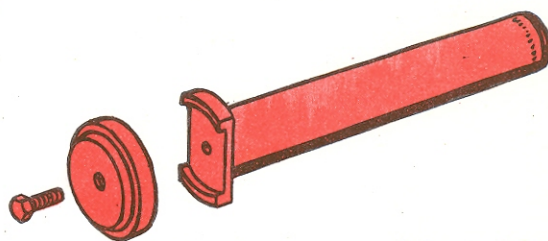

**A.3.0152**

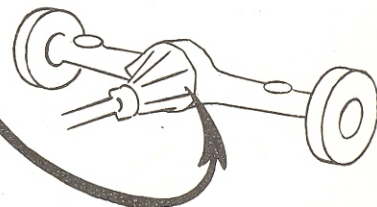
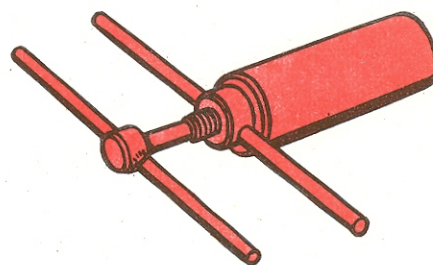

- 2 Tools A.3.0148 and A.3.0149 are used to withdraw and to insert the outside rings "C" and "D" of the pinion bearings (A.3.0148 for "C" and A.3.0149 for "D")

- 3 Tool A.3.0152 is used to insert the inside ring "E" of the front bearing of pinion.

GENERAL TOOLS	
SPECIAL TOOLS	X
MACHINERY	
EQUIPMENT	
MISCELLANEOUS	

# Alfa Romeo

DIREZIONE ASSISTENZA CLIENTI

DATE

18-3-1969

SEQUENT NUMBER

97/3

## Tooling News

Giulia

### WITHDRAWAL OF STEERING WHEEL

A.3.0158/1

- 1 Free the nut securing steering wheel to shaft from the safety plate and unscrew the nut.
- 2 Bring the abutment "A" and the plate "B" almost as close as in contact by rotating the screw "C".
- 3 Fit the tool by securing the studs "D" into threaded holes in the steering wheel flange.

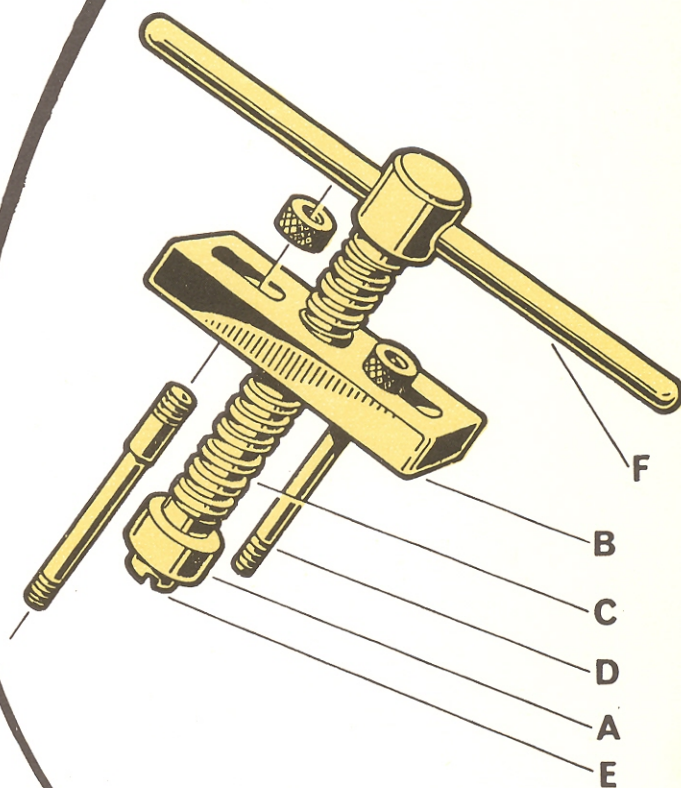
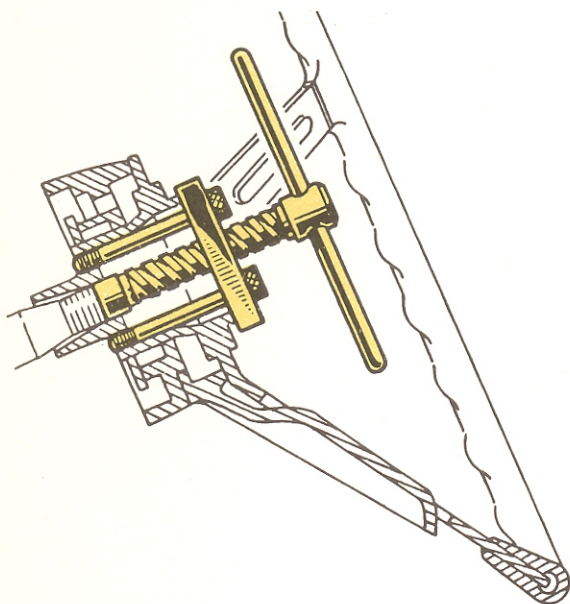

- 4 Make sure the screw "C" is well centered on shaft end and introduce the dowel "E" of abutment "A" into the shaft bore.
- 5 Rotate the handle "F" to withdraw the wheel.

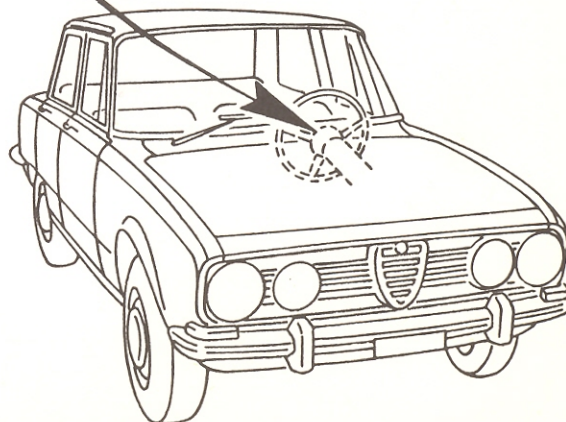

This Bulletin deletes and supersedes the I.B. no. 97/2 dated 18/6/1966

GENERAL TOOLS	
SPECIAL TOOLS	X
MACHINERY	
EQUIPMENT	
MISCELLANEOUS	

# Alfa Romeo

DIREZIONE ASSISTENZA

## Tool Bulletin

DATE

28-2-1973

SEQUENT NUMBER

97/4

Giulia - 1750  
2000 - Montreal  
Alfetta - F 12

### WITHDRAWAL OF STEERING WHEEL

A.3.0451

- 1 Free the nut securing steering wheel to shaft from the safety plate and unscrew the nut.
- 2 Bring the abutment "A" and the plate "B" almost as close as in contact by rotating the screw "C".
- 3 Fit the tool by securing the studs "D" into threaded holes in the steering wheel flange.
- 4 Make sure the screw "C" is well centered on shaft end and introduce the dowel "E" of abutment "A" into the shaft bore.  
On the Alfetta model only, the spherical boss of dowel "E" should abut against the shaft end to withdraw the wheel.
- 5 Rotate the handle "F" to withdraw the wheel.

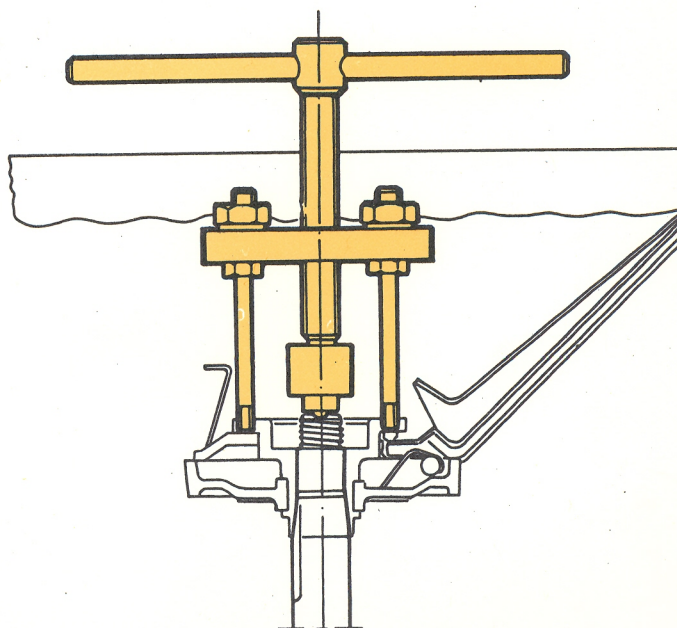
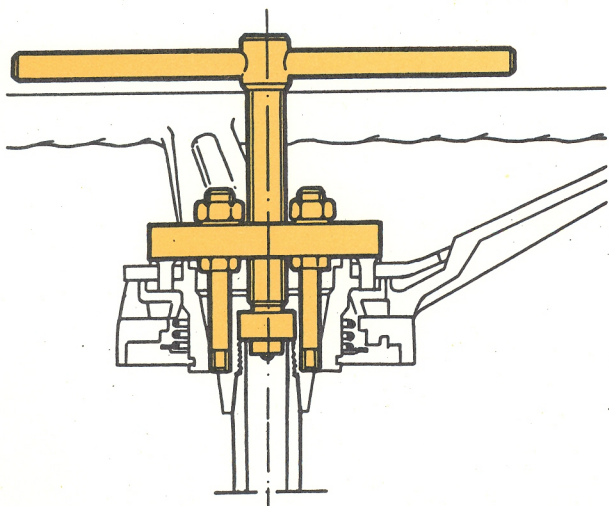
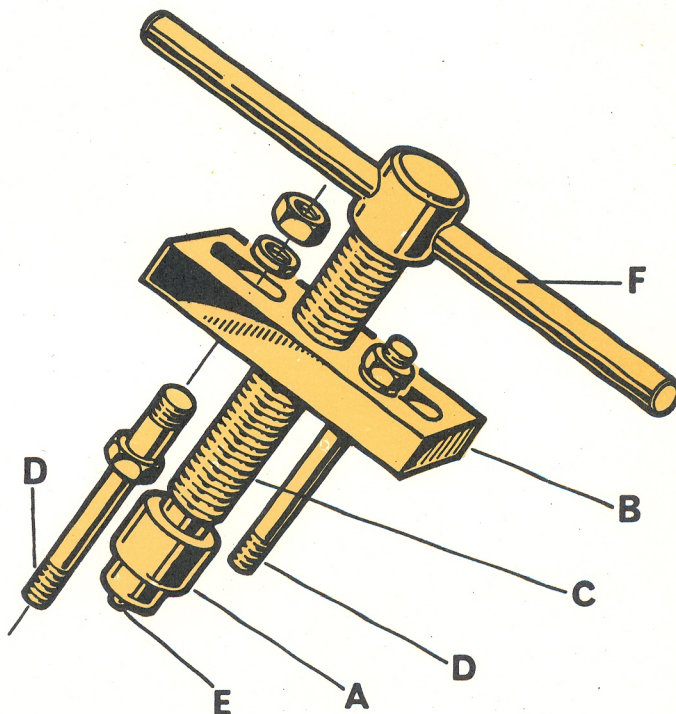

Deletes and supersedes I.B.  
No. 97/3 dated 18/3/1969

GENERAL TOOLS	
SPECIAL TOOLS	X
MACHINERY	
EQUIPMENT	
MISCELLANEOUS	

# Alfa Romeo

DIREZIONE ASSISTENZA

DATE

28-2-1973

SEQUENT NUMBER

98/1

## Tool Bulletin

All models

### WITHDRAWING THE BALL JOINTS OF STEERING LINKAGE AND STUB AXLE

- 1 Remove the ball joint fastening nut. Place the tool in position on ball joint bracket paying attention not to damage, with the yoke "A", the rubber boot containing the grease.
- 2 Bring the abutment "B" close to the shank of the ball joint being withdrawn by rotating the screw "C".
- 3 Rotate further the screw "C" until the ball joint shank comes out of its seat.

A.3.0157

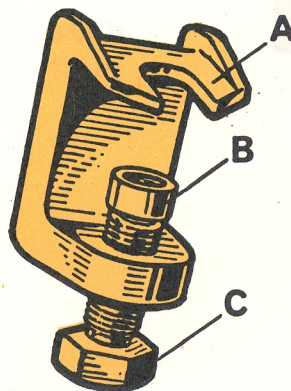

A.3.0156  
A.3.0376

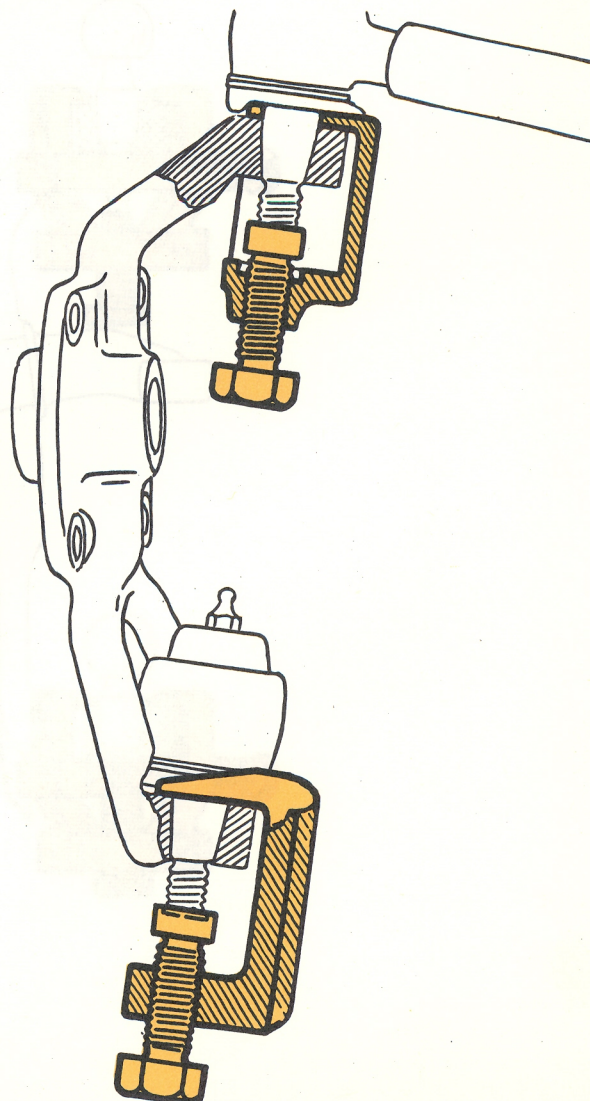
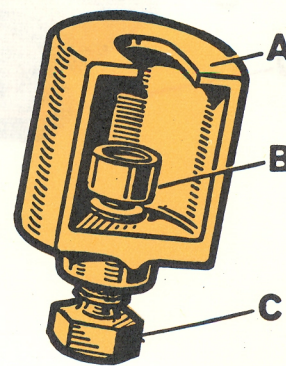

#### APPLICABILITY

- A.3.0156 - It is used for withdrawing the ball joint at stub axle top (Giulia - F 12 - 1750 - 2000 - Montreal models)
- A.3.0157 - It is used to withdraw the ball joint at the stub axle bottom and steering arm joint (Giulia - F 12 - 1750 - 2000 - Montreal models)
- A.3.0376 - It is used to withdraw the steering arm joint (Alfetta - Alfasud)
- A.3.0377 - It is used to withdraw the stub axle ball joint (Alfetta model)

Deletes and supersedes I.B.  
No. 98 dated 25/9/962

4 The tool A.3.0377 is used for withdrawing the ball joints at the top and bottom of stub axle of the Alfa Romeo model.

5 The shackle "D", suitably positioned and locked in place by setscrew "E", allows to engage the jaws "A" more deeply and firmly in between the stub axle bracket and the ball joint thus facilitating joint withdrawal.

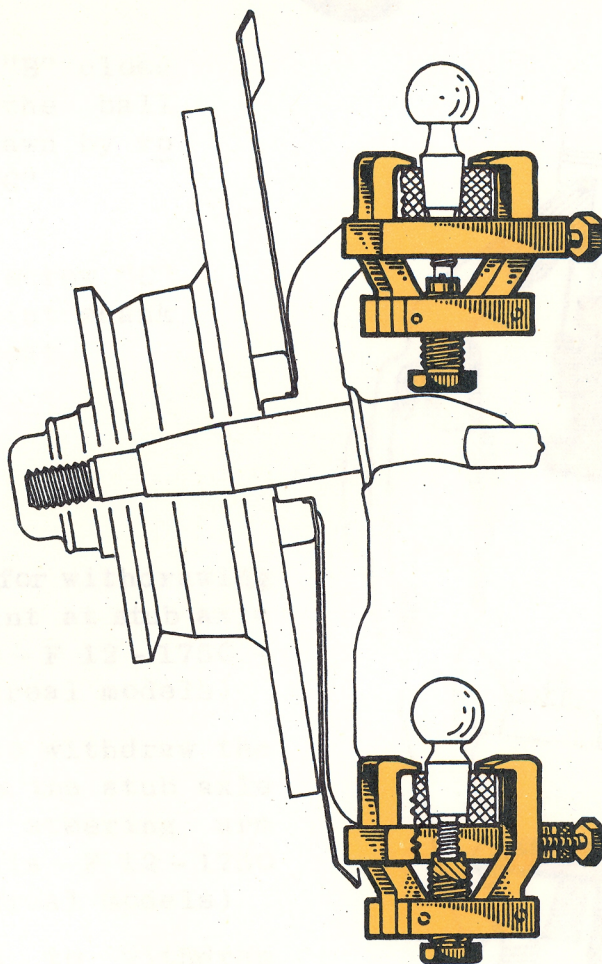
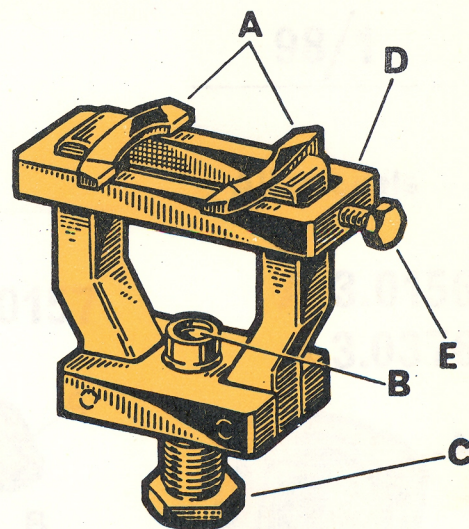

GENERAL TOOLS	
SPECIAL TOOLS	<b>X</b>
MACHINERY	
EQUIPMENT	
MISCELLANEOUS	

# Alfa Romeo

DIREZIONE ASSISTENZA

## Tool Bulletin

DATE

28-2-1973

SEQUENT NUMBER

99/2

Giulia - 1750  
2000 - Montreal

### A.3.0159

## FITTING THE BUSHES TO THE FRONT SUSPENSION WISHBONES

- 1 Insert the threaded shank "A" of the tool base "B" into the wishbone lug. Place the rubber bush "E" in position and fit the cup "C"
- 2 Drive the bush "E" into its seat by screwing in the nut "D".
- 3 To withdraw the bush use a rod and tap the bush out as shown. The bush must be renewed.

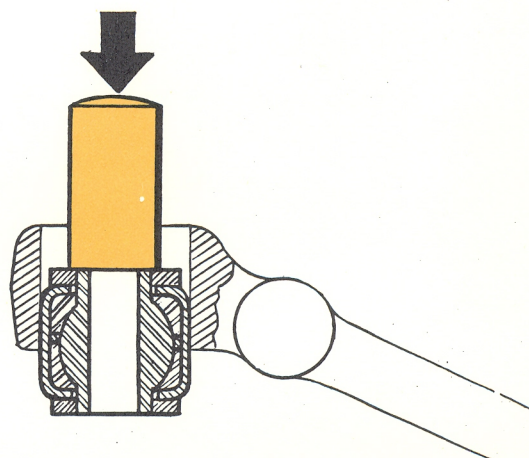
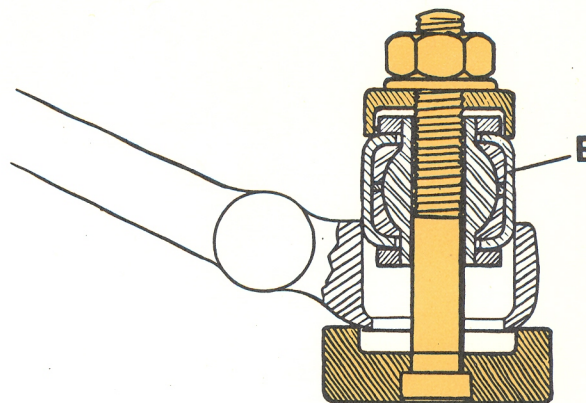
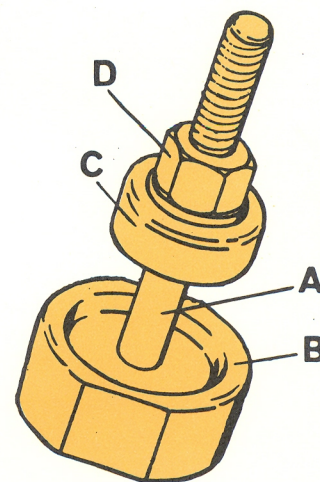

Deletes and supersedes T.B.  
No. 99/1 dated 10/1/1967

GENERAL TOOLS	
SPECIAL TOOLS	X
MACHINERY	
EQUIPMENT	
MISCELLANEOUS	

*Alfa Romeo*  
DIREZIONE ASSISTENZA

*Tool Bulletin*

DATE	20-5-1964
SEQUENT NUMBER	100/1
<b>Giulia</b>	

DRIVING AND REMOVING  
THE BEARING CUPS OF FINAL DRIVE PINION

A. 3.0207

**1** Removing the rear bearing cup.

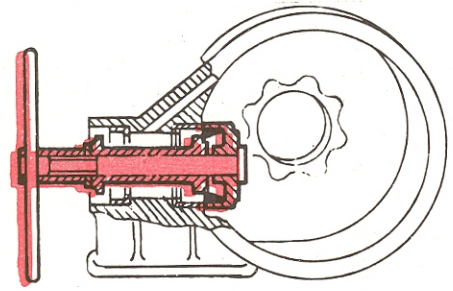

**2** Driving the rear bearing cup.

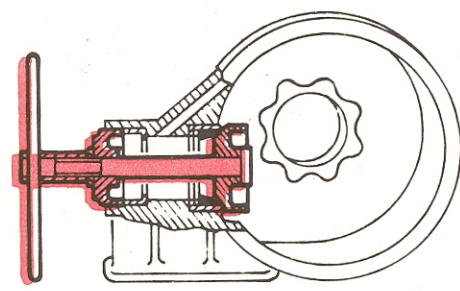

**3** Removing the front bearing cup.

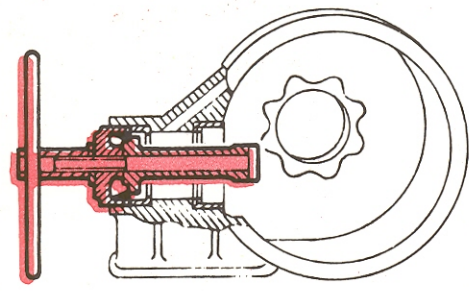

**4** Driving the front bearing cup.

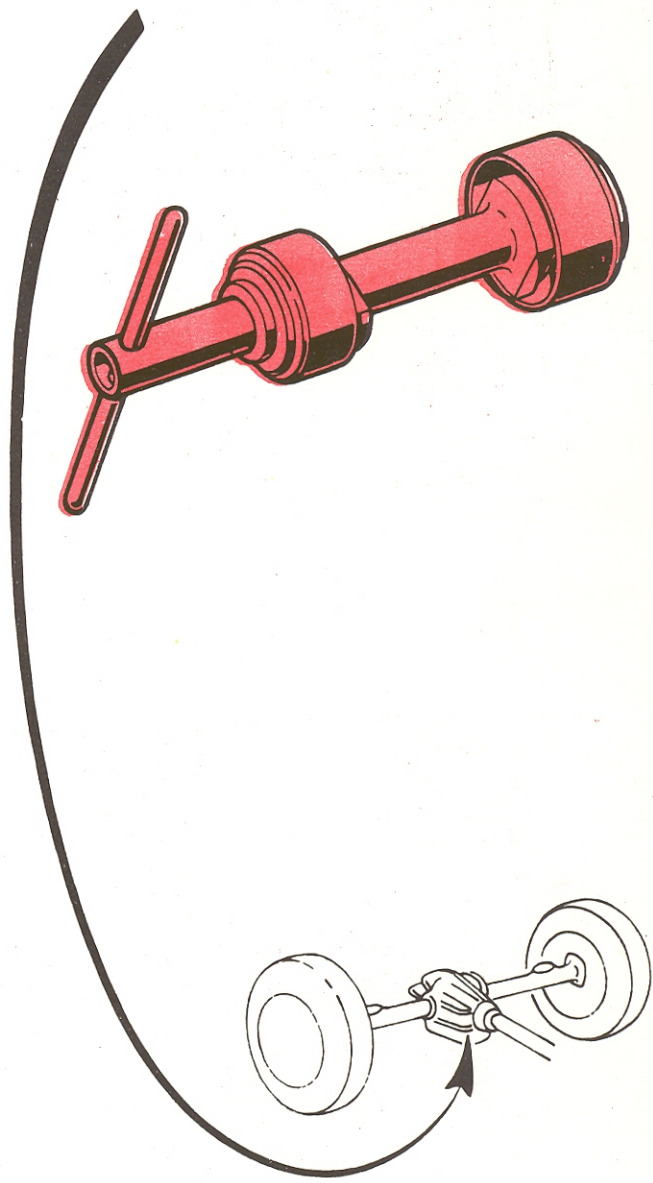
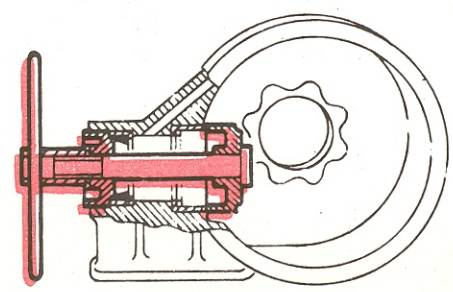

GENERAL TOOLS	
SPECIAL TOOLS	X
MACHINERY	
EQUIPMENT	
MISCELLANEOUS	

# Alfa Romeo

DIREZIONE ASSISTENZA

DATE

27-6-1973

SEQUENT NUMBER

100/2

All models

## Tool Bulletin

### WITHDRAWAL AND FITMENT OF OUTER RACES OF PINION AND DIFFERENTIAL BEARINGS

A.3.0207 Giulia - 1750

A.3.0399 2000

A.3.0277 Montreal

#### REAR PINION SHAFT BEARING

- 1 Carry out the steps preliminary to the withdrawal of the outer races of pinion shaft bearings as outlined in the Shop Manual.
- 2 Withdrawal  
For the withdrawal of the rear pinion shaft bearing, select the tool applicable to the model being overhauled and proceed as follows.
- 3 Insert the screw "1" complete with the cup "2" (see fig. 1) into the pinion housing in such a way that the tool cup abuts against the seat of the bearing race.
- 4 Install the sleeve "3" onto the screw "1" so that the larger end of sleeve faces the bearing race.
- 5 Fit the handle "4" to the screw "1" and rotate it to withdraw the bearing outer race (see fig. 2).

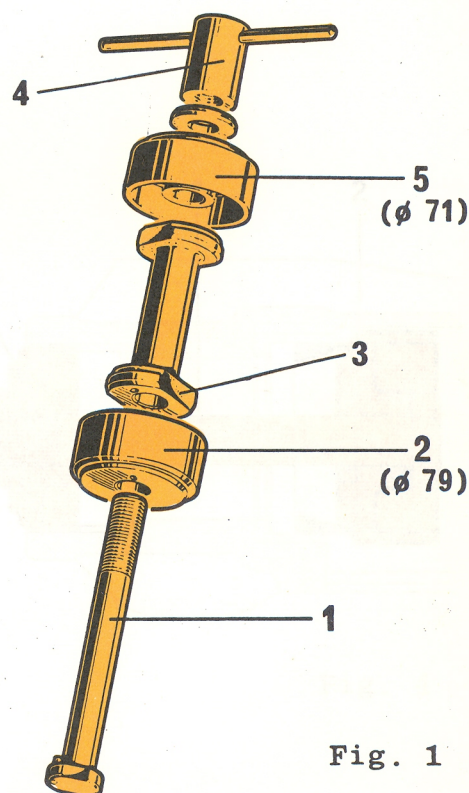

Fig. 1

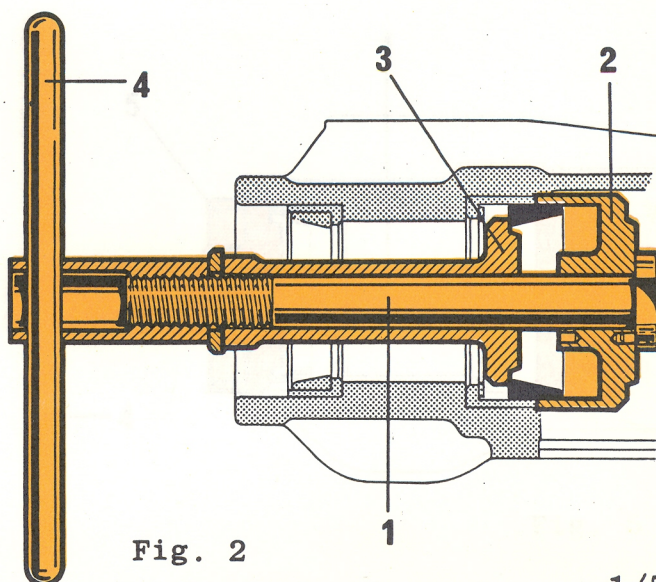

Fig. 2

Deletes and supersedes T.B.  
No. 100/1 dated 20/5/1964

## FRONT PINION SHAFT BEARING

6 To withdraw the front bearing outer race, insert the screw "1" complete with the sleeve "3" into the pinion housing. The larger end of sleeve must face the race to be withdrawn.

7 Fit the cup "2" and the handle "4" to the screw "1". Rotate the handle to withdraw the race (see fig. 3).

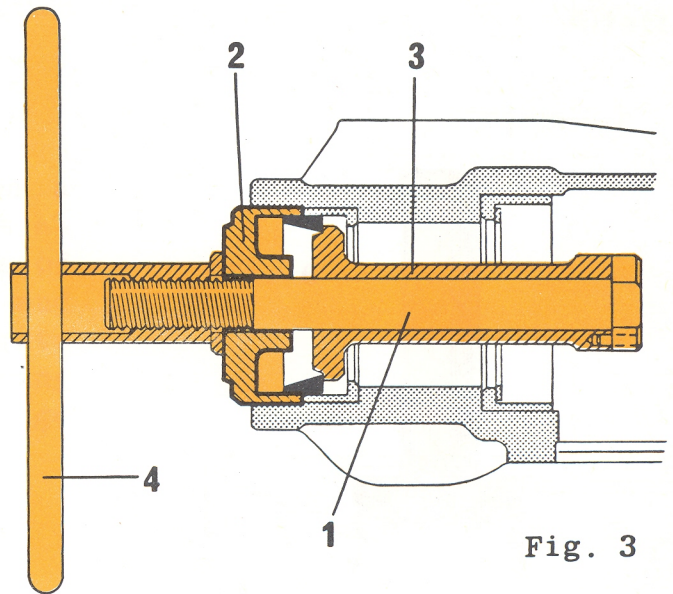

Fig. 3

### 8 Fitment

To fit the rear bearing outer race, reverse the withdrawal position of the cup "2" (see fig. 3). Place the race to be fitted in position on the tool; clean with compressed air the bearing race seat and insert the unit so assembled into the pinion housing (see fig. 4).

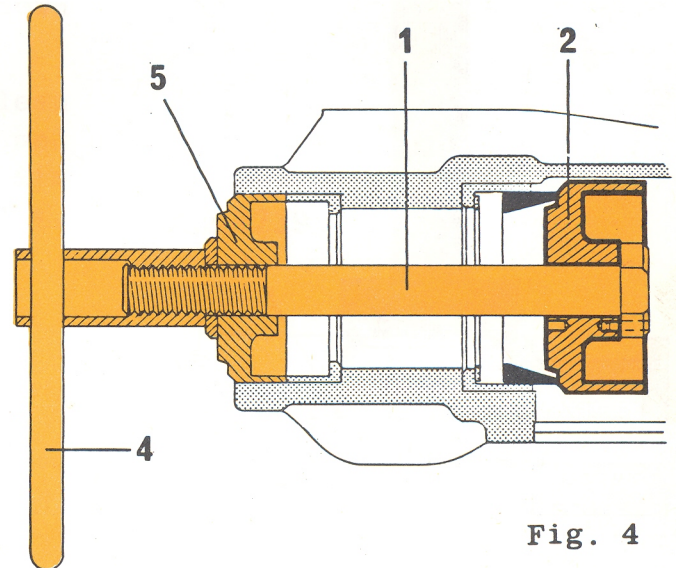

Fig. 4

9 Fit the cup "5" and the handle "4" to the screw "1"; rotate the handle taking care to keep the tool aligned with the bore centreline to drive the race into its seat (see fig. 4).

10 To fit the front bearing outer race (see fig. 5), repeat the steps 3 and 9, keeping in mind that the position of cup "5" must be reversed with respect to the position it had at step 9.

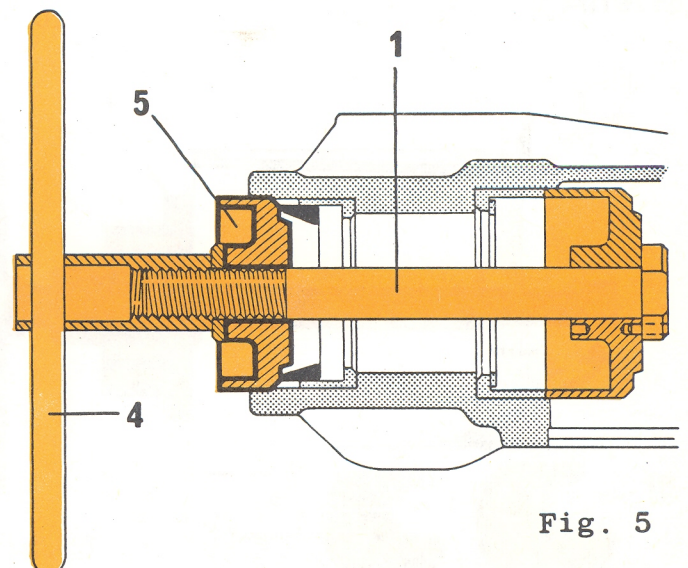

Fig. 5

BEARING IN PINION SHAFT INTERMEDIATE FLANGE

**A.3.0408**  
Alfetta

**11** Withdrawal

Place the intermediate flange on a press; make certain the tool is aligned with both the centreline of press plunger "6" (see fig. 6) and the bearing race centreline. Operate the press to withdraw the bearing race paying attention not to damage the intermediate flange.

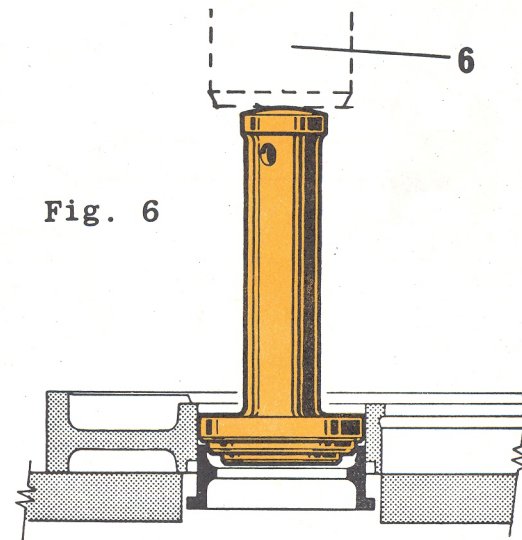

Fig. 6

**12** Fitment

Proceed in the same way as directed above except that the intermediate flange must be placed upside down on the tool A.2.0239.

Prior to fit the bearing race, clean the seat with compressed air and make certain that the race and its seat are exactly in line (see fig. 7).

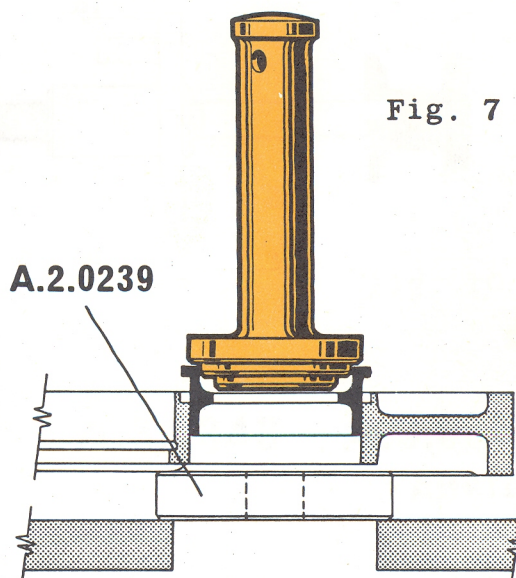

Fig. 7

REAR PINION SHAFT BEARING

**13** Withdrawal

Place the tool A.3.0348 in line with the pinion rear bearing centreline and rest the cross-member "9" (see fig. 8) against the outer edge of casting.

**14** Remove the ring "10" and the half-bushing "11" from the tool A.3.0248 (see fig. 8) and install the tool A.3.0364 (see fig. 9).

Refit the bushing "11" and the ring "10" to their position on the tool A.3.0348.

**A.3.0364 - A.3.0348**  
Alfetta

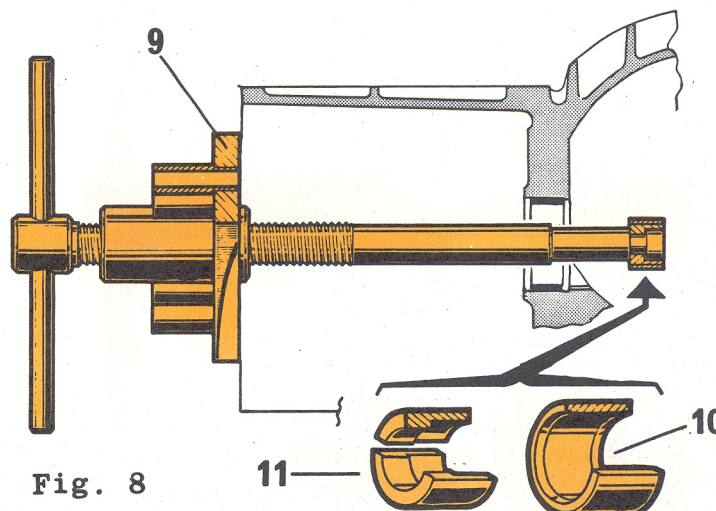

Fig. 8

- 15 Align the tool with the bearing seat centreline and withdraw the rear bearing race by rotating the handle "12" (see fig. 9).

16 Fitment

Place the tool in the same position as shown at fig. 9 except that tool A.3.0364 should be in a slightly backward position.

Install the race to be fitted onto the tapered edge of the tool; then, rotate the handle "12" to drive the race into its seat (see fig. 10).

REAR MAINSHAFT BEARING

- 17 Proceed the same way as outlined by steps 13 - 14 - 15 - 16 to withdraw and fit the rear mainshaft bearing with the aid of tool A.3.0363.

REAR PINION BEARING

18 Withdrawal

Remove the bushings "17" and "18" and the plate "14" and insert the tool into the seat of the bearing race to be withdrawn. Rest the flange "13" against the outer edge of casting as shown at fig. 11.

- 19 Centre the plate "14" on the protruding edge of bearing race and rotate the handle "15" until the race is withdrawn (see fig. 11).

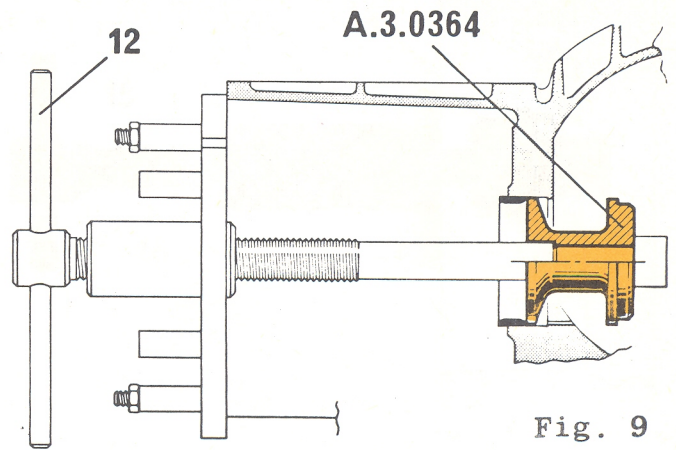

Fig. 9

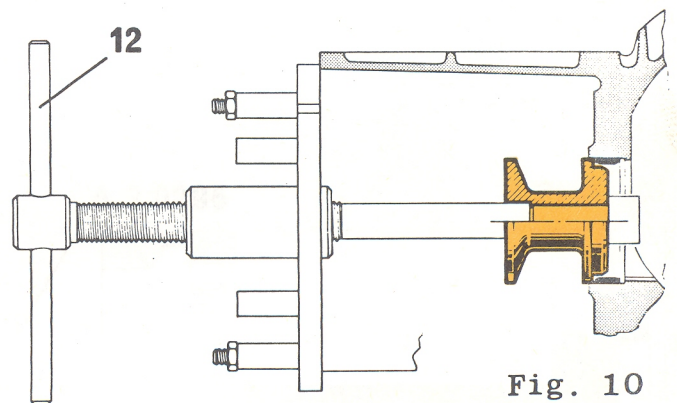

Fig. 10

**A.3.0348 - A.3.0363**  
Alfetta

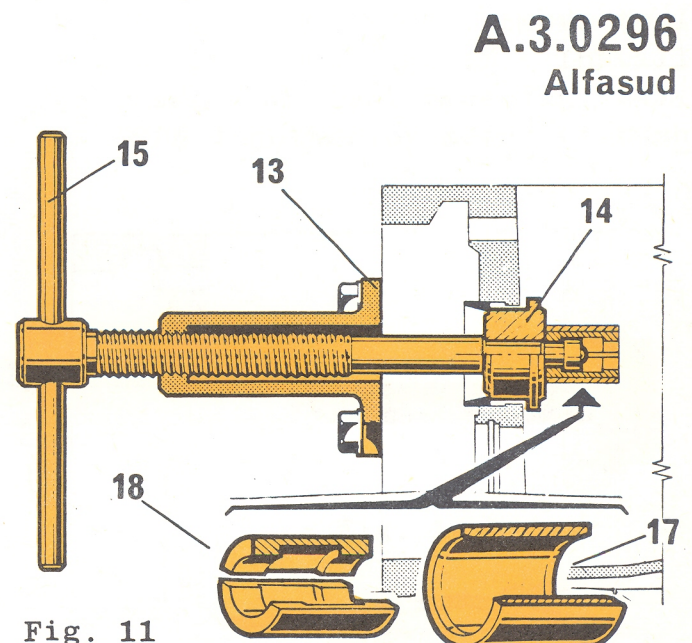
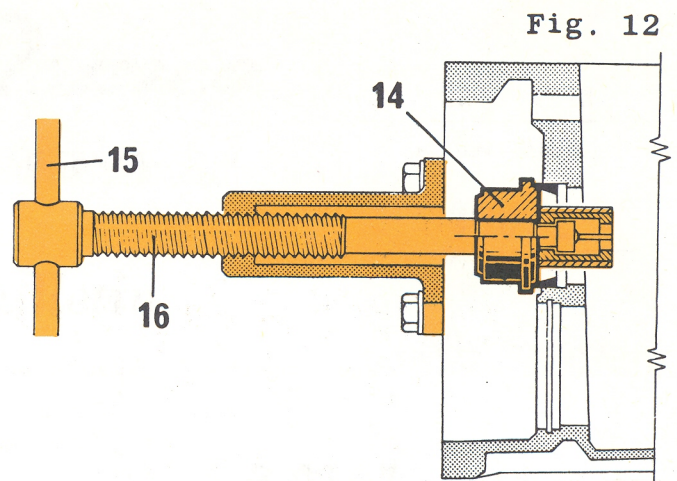

Fig. 11

**A.3.0296**  
Alfasud

- 20** Fitment  
 Rotate the handle "15" to back up the screw "16" until enough space is left to place the race to be fitted in position onto the tapered edge of plate "14" (see fig. 12)



- 21** Clean the race seat with compressed air. Align carefully the tool with the seat and rotate the handle "15" to seat the race fully.

FRONT PINION BEARING

**A.3.0296 - A.3.0297**

Alfasud

- 22** Withdrawal  
 Repeat step "17" then fit the tool A.3.0297 to the tool A.3.0296 (by means of the bushings "18" and "17" - see fig. 11).  
 Operate the tool until it abuts against the front bearing race as shown at fig.13.

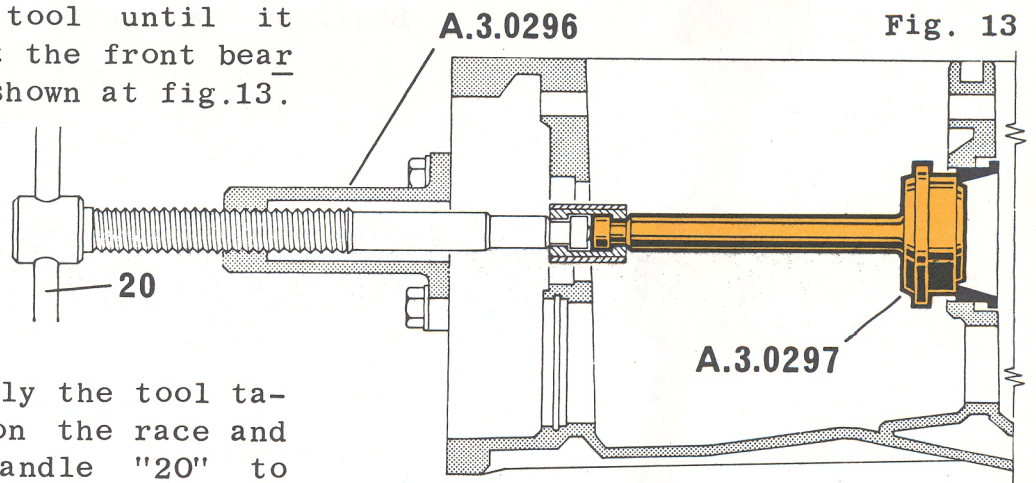

- 23** Centre properly the tool tapered edge on the race and rotate the handle "20" to withdraw the race.

- 24** Fitment  
 Bring tool A.3.0296 all the way in forward position; remove tool A.3.0297 by releasing bushings "17" and "18" (see fig. 11). Install the race to be fitted onto the tapered edge of tool (see fig. 14), again connect tools A.3.0297 and A.3.0296 together by means of bushings "17" and "18", then, clean the seat and rotate the handle "20" to fit the bearing race into its seat.  
 To remove the tool, release the bushings "17" and "18".

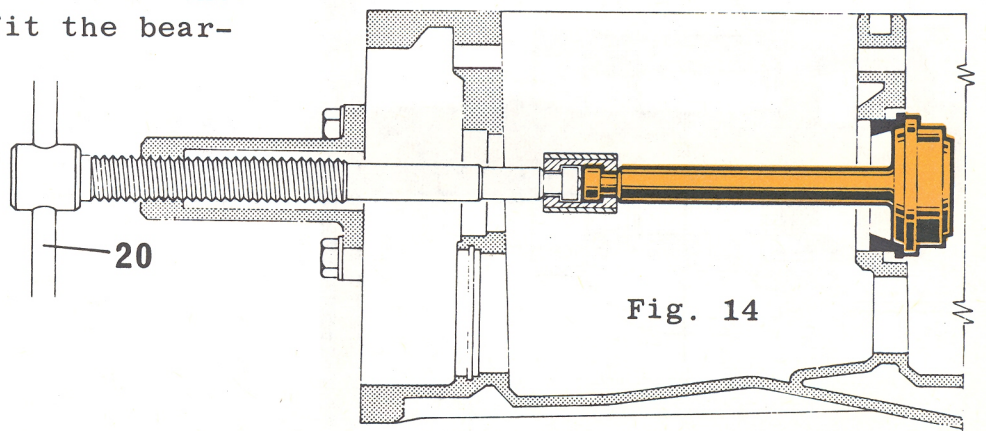

GENERAL TOOLS	
SPECIAL TOOLS	X
MACHINERY	
EQUIPMENT	
MISCELLANEOUS	

# Alfa Romeo

DIREZIONE ASSISTENZA

DATE

26-2-1973

SEQUENT NUMBER

101/1

## Tool Bulletin

Giulia - 1750  
2000 - Montreal

### WITHDRAWAL AND FITMENT OF T-ARM RUBBER BUSH ASSY

A.3.0163

#### WITHDRAWAL

- 1 Remove the T-arm from the car.
- 2 Slacken the screw "C" and secure the plate "B" to the flange of rubber bush assembly with the screws "A".
- 3 Tighten the screw "C" to stretch the rubber until the distance "D" is enough to allow to install the half-plates "E". See fig. 1 and 2.
- 4 Make sure that the two teeth "F" engage in the notches of the bush inner sleeve; then, slacken the screw "C" so as to press the half-plates "E" in between rubber bush and T-arm "G".
- 5 Remove the plate "B" and, with the aid of a press, withdraw the bush from the T-arm spindle "H" by reaction against half-plates "E". See fig. 3.

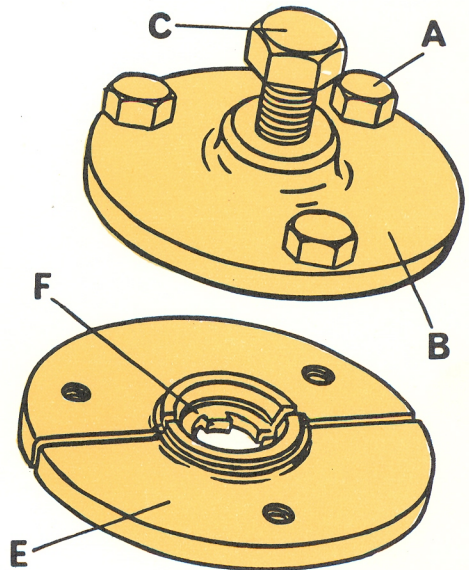

A.3.0164

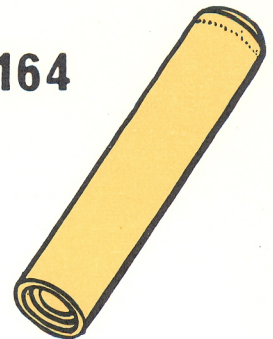

#### FITMENT

- 6 Align the reference notches in the rubber bush with those in the T-arm and fit the rubber bush onto the T-arm spindle with the tool A.3.0164. See fig. 4.

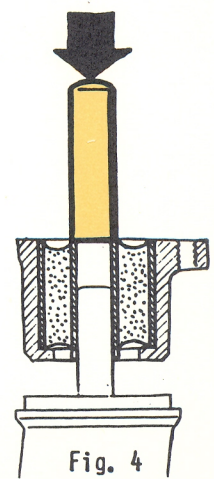
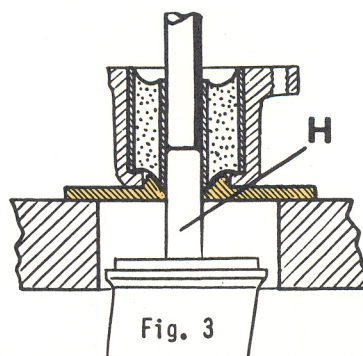
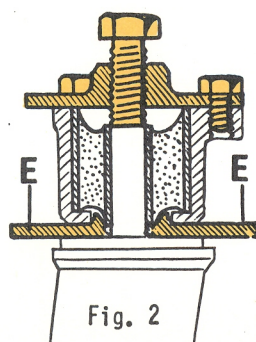
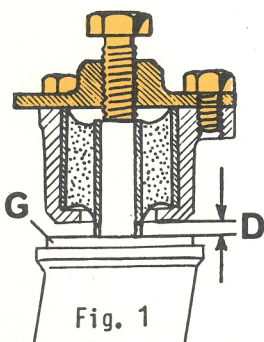

Deletes and supersedes I. B.  
 No. 101 dated 25/9/1962

GENERAL TOOLS	
SPECIAL TOOLS	X
MACHINERY	
EQUIPMENT	
MISCELLANEOUS	

# Alfa Romeo

DIREZIONE ASSISTENZA CLIENTI

DATE

18-3-1969

SEQUENT NUMBER

102/2

## Tooling News

**GIULIA**  
**1750**

### SHIMMING THE L.H. BEARING OF DIFFERENTIAL CARRIER

**C.6.0115**

- 1 Fit the tool C.6.0115 in place of the L.H. axle shaft housing.

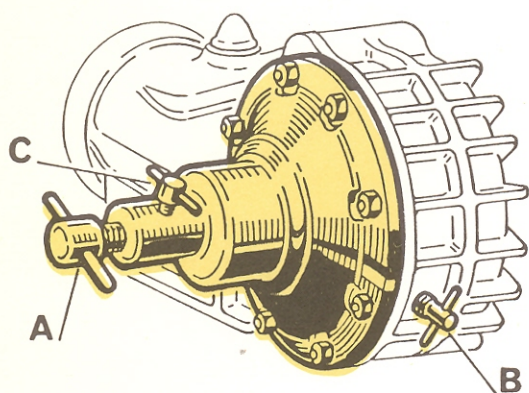

- 2 Adjust screw "A" so as to obtain clearance and pre load as specified in the shop manual. While taking clearance readings, lock the ring gear by means of setscrew "B" acting through the drain plug.
- 3 Lock the setscrew "C".
- 4 Remove the tool from differential carrier and using the jig C.6.0102 and a dial gauge measure the dimension "D".

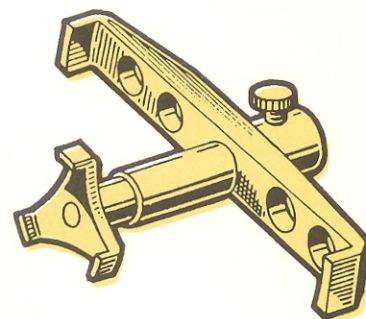
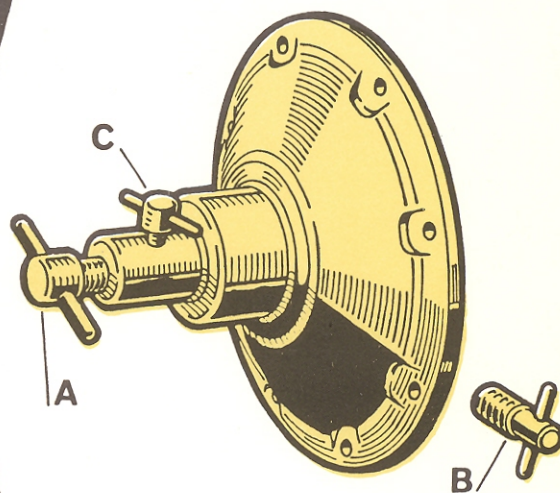

**C.6.0102**

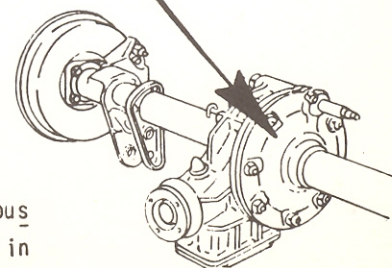
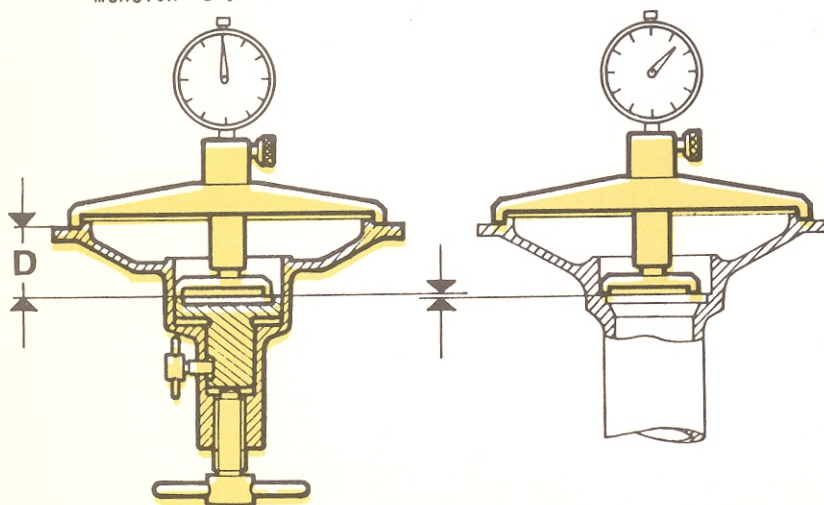

- 5 Now take a reading of the dimension "D" also in the L.H. axle shaft housing and, by difference, compute the thickness of shims to be inserted in the seat of differential carrier L.H. bearing cup.

GENERAL TOOLS	
SPECIAL TOOLS	X
MACHINERY	
EQUIPMENT	
MISCELLANEOUS	

# Alfa Romeo

DIREZIONE ASSISTENZA CLIENTI

Tooling News

DATE

30-3-1972

SEQUENT NUMBER

102/3

Giulia - 1750  
2000 - Montreal

**C.6.0115**

Giulia - 1750

**C.6.0157**

2000 - Montreal

## SHIMMING THE L.H. BEARING OF DIFFERENTIAL CARRIER

- 1 Fit the tool as applicable in place of the L.H. axle shaft housing. To prevent misreadings, tighten firmly all nuts "E" (Figure 2).
- 2 Adjust screw "A" so as to obtain clearance and preload as specified. While taking clearance readings, lock the ring gear by means of setscrew "B" acting through the drain plug (Figure 2).
- 3 Lock the setscrew "C". Remove the tool from the differential carrier.

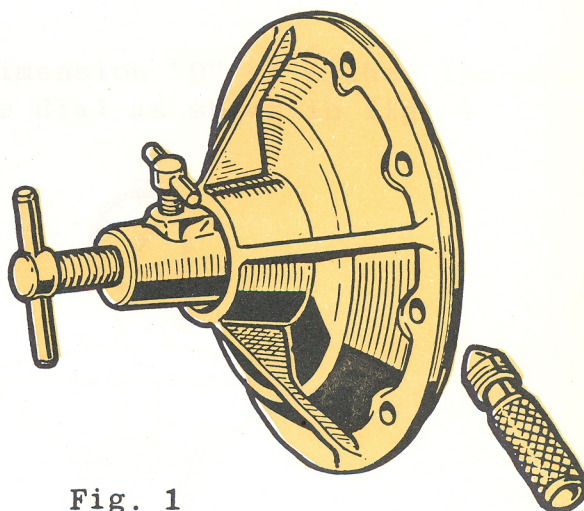

Fig. 1

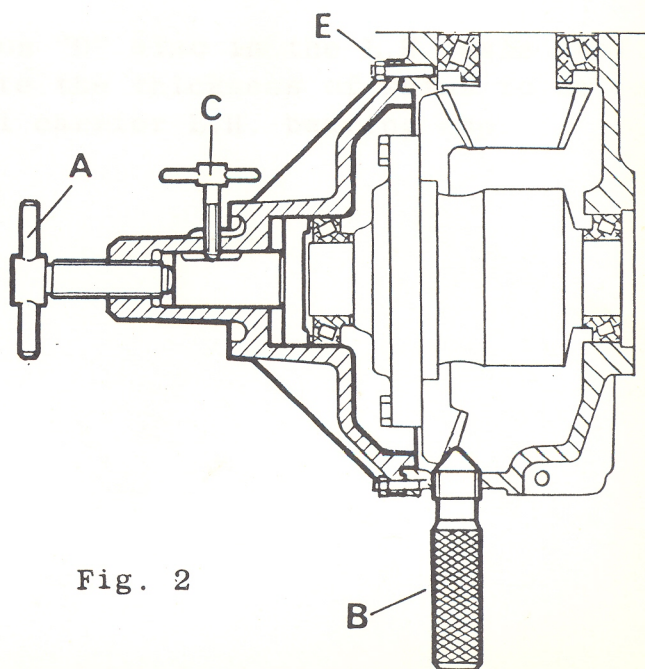

Fig. 2

This Bulletin deletes and supersedes the T.B. no. 102/2 dated 18/3/1969

- 4 Fit a dial gauge with a probe travel of 10 mm (e.g. C.1.0013) on the jig (C.6.0102 or C.6.0160). To read all the travel of yoke "F" (Figure 3) through, preset the dial gauge probe by a few millimetres only.

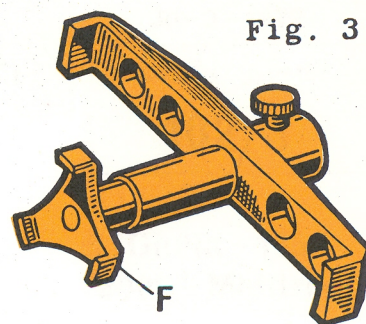

Fig. 3

**C.6.0102**

Giulia - 1750

**C.6.0160**

2000 - Montreal

- 5 With the jig so prepared, read the dimension "D" of either the special tool C.6.0115 or C.6.0157 on the dial as shown in fig. 4.

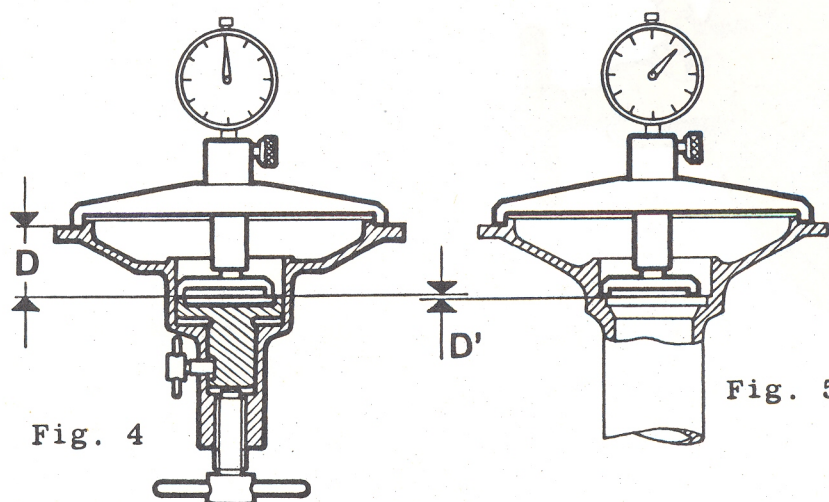

Fig. 4

Fig. 5

- 6 Now take a reading of the dimension "D" also in the L.H. axle shaft housing and, by difference, compute the thickness of shims to be inserted in the seat of differential carrier L.H. bearing cup.

GENERAL TOOLS	X
SPECIAL TOOLS	
MACHINERY	
EQUIPMENT	
MISCELLANEOUS	

# Alfa Romeo

DIREZIONE ASSISTENZA

## Tool Bulletin

DATE

28-2-1973

SEQUENT NUMBER

103/1

Giulia - 1750 - F 12  
2000 - Montreal  
Alfetta - Alfasud

### GAUGE FOR CHECKING VALVE GUIDE BORE

C.1.0028

- 1 Select the probe approaching more closely the diameter of the guide bore; fit the probe to the gauge and secure firmly with the setscrew "A".
- 2 Apply a micrometer to the ball end of probe "C" and set the gauge to zero by means of the screw "B".
- 3 Insert the probe of the gauge into the valve guide bore and take readings as follows:
  - if the size of the bore is smaller than the rated diameter, the needle will indicate the difference at the right side of the dial marked with the symbol - (minus) in red colour.
  - if the size of the bore is larger than the rated diameter the needle will indicate the difference at the left side, i.e. that marked with the symbol + (plus) in red colour.

**NOTE** - The symbols (+) plus and (-) minus in black on the gauge dial have no particular meaning.

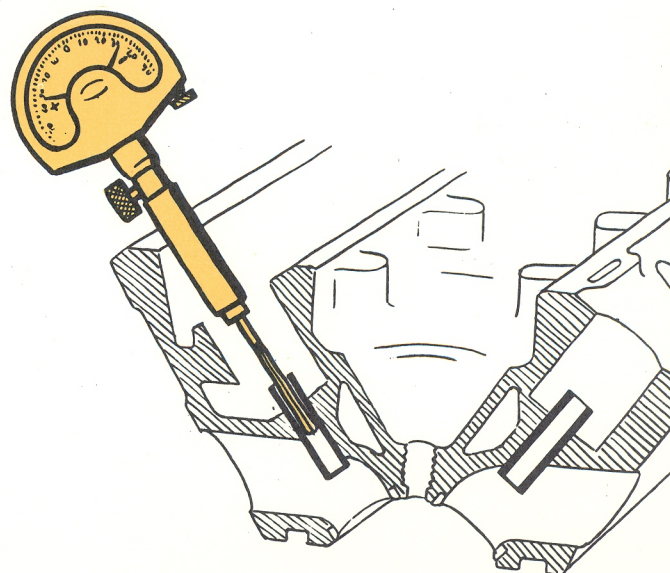
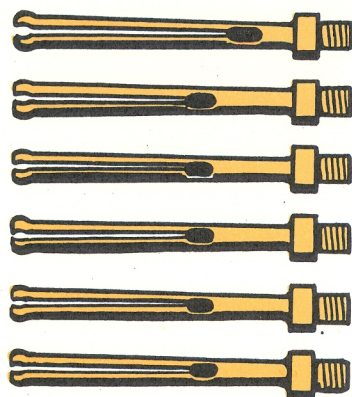
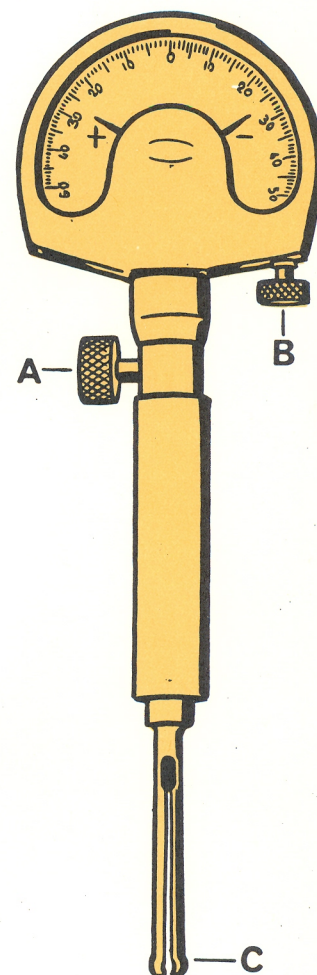

Deletes and supersedes T.B.  
No. 103 dated 25/9/1962

GENERAL TOOLS	
SPECIAL TOOLS	X
MACHINERY	
EQUIPMENT	
MISCELLANEOUS	

# Alfa Romeo

DIREZIONE ASSISTENZA CLIENTI

## Tooling News

DATE  
9-1-1964

SEQUENT NUMBER  
108

GIULIA

### ADJUSTMENT OF PLAY ON COLUMN MOUNTED GEARSHIFT LEVER

A.5.0125

- 1 Remove the plastic jackets of steering column
- 2 Remove the chromium-plated moulding covering the ring nuts "C" and "D"
- 3 Unscrew the ring nut "D" by using the wrench "A"
- 4 Adjust the ring nut "C" by using the wrench "B"

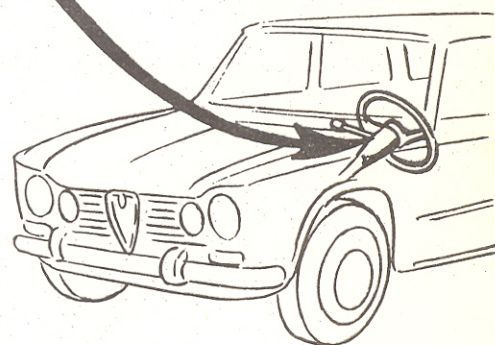
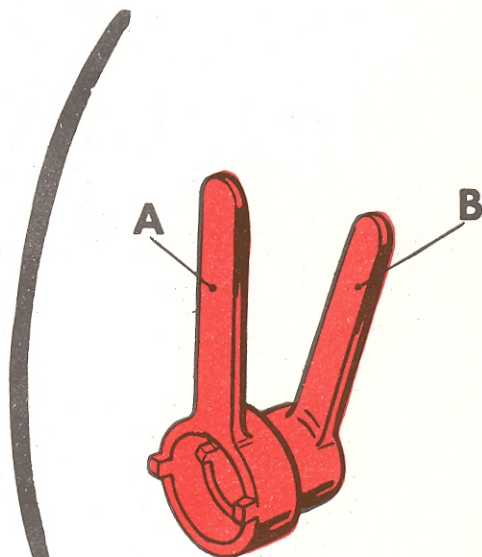
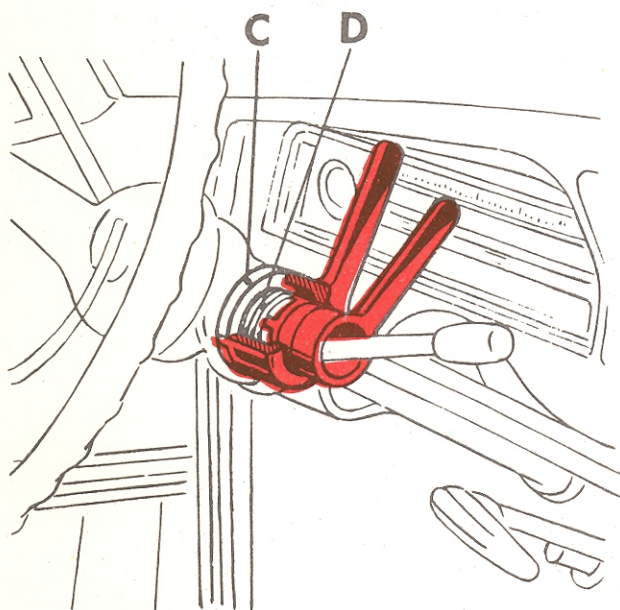

- 5 Holding the ring nut "C" stationary lock the ring nut "D" in place
- 6 Refit the chromium-plated moulding and the plastic jackets

Translated in October 1965

GENERAL TOOLS	
SPECIAL TOOLS	X
MACHINERY	
EQUIPMENT	
MISCELLANEOUS	

# Alfa Romeo

DIREZIONE ASSISTENZA

## Tool Bulletin

DATE

26-2-1973

SEQUENT NUMBER

110/1

Giulia - 1750  
2000 - Montreal

A.5.0146

### TORQUE SPANNER FOR NUTS OF REAR AXLE TUBE FLANGES

- 1 Check that the reference line "A" on the pointer "B" is aligned with the mark on the rod "C".
- 2 Tighten nuts "D" as shown until a light click is heard.
- 3 The spanner is calibrated to release the torque at 5.5/5.8 Kgm; at this torque the line "E" on the pointer "B" should be aligned with the mark on rod "C".
- 4 The torque should not be applied with an excessively slowly action or the click would not be felt distinctly. However, a visual check for proper torque can always be done as outlined in "3" above.

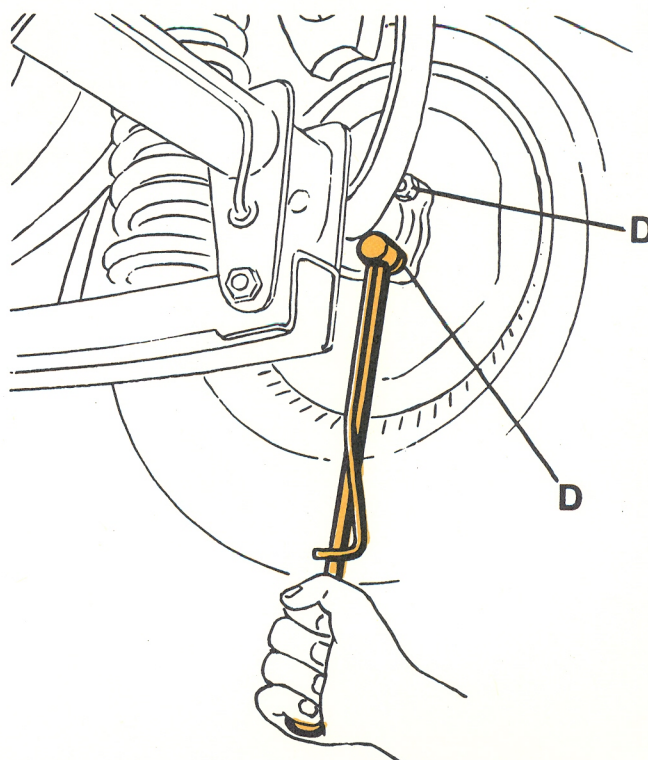
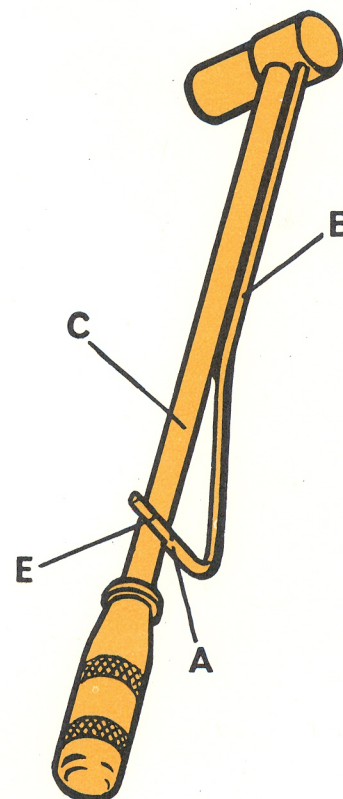

Deletes and supersedes T.B.  
No. 110 dated 10/9/1963

GENERAL TOOLS	
SPECIAL TOOLS	X
MACHINERY	
EQUIPMENT	
MISCELLANEOUS	

# Alfa Romeo

DIREZIONE ASSISTENZA CLIENTI

*Tooling News*

DATE  
30-3-1972

SEQUENT NUMBER  
**114/1**

Giulia - 1750  
2000 - Montreal

**A.2.0143**

## REMOVAL AND REINSTALLATION OF REAR SUSPENSION SPRINGS

### Models with disc brakes

- 1 Place the car on a lift or over a pit. To facilitate the removal of the spring the car should be positioned slightly offset with respect to the centreline of the lift or pit so that the affected area is free from obstructions (see figure 1).
- 2 Support the car with a hydraulic jack at the side of the spring to be removed or put it on stands.

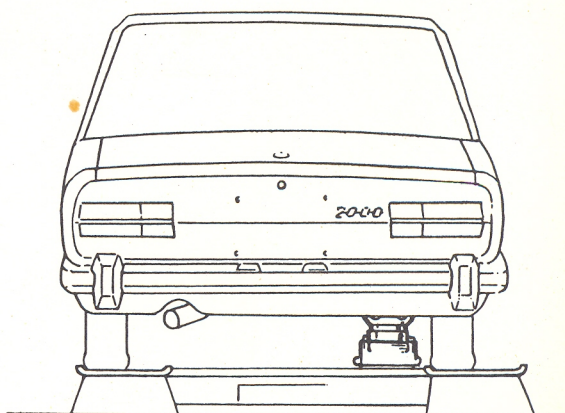
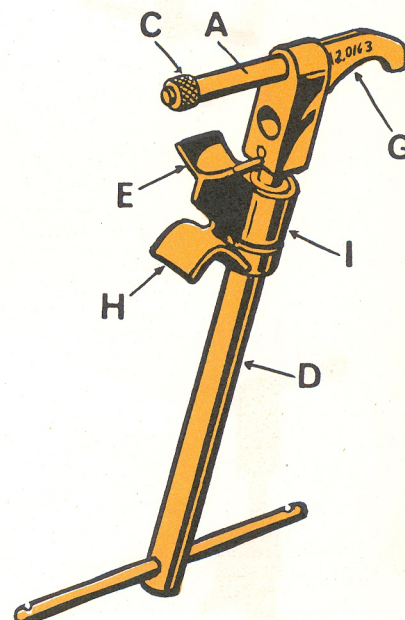

Fig. 1

This Bulletin deletes and supersedes the T.B. no. 114 dated 1/2/1964

- 3 Prepare the tool taking care to direct the bracket assembly "I" as shown in fig. 2.
- 4 Insert pin "A" into hole "B" and tighten nut "C".
- 5 Rotate handle "D" until the bracket "E" rests firmly against the radius rod attachment as shown in fig. 2.
- 6 Remove the mounting bolt "F" and rotate the handle "D" in such a way as to relieve the spring fully.
- 7 To reinstall the spring, reverse the removal procedure taking care, while starting compressing the spring, to centre the lower end of spring properly in its seat.

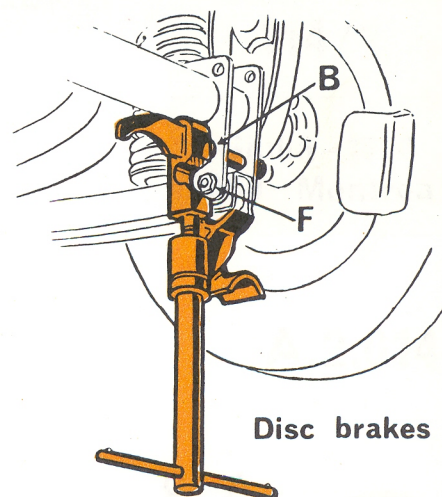

Fig. 2

#### Models with drum brakes at rear wheels

The procedure is the same as for disc brake models except that

- 1 The bracket assembly "I" must be turned upside down as shown.
- 2 The beak "G" must engage the axle tube.
- 3 The bracket "H" must be brought against the radius rod attachment as shown in fig. 3.

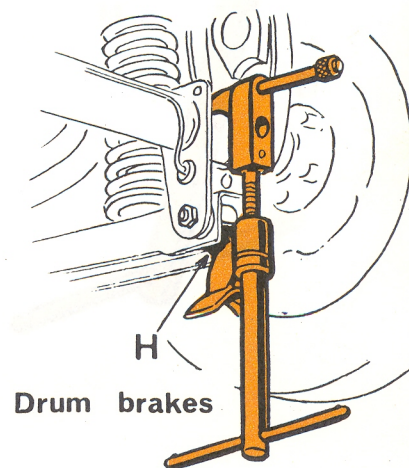

Fig. 3

GENERAL TOOLS

SPECIAL TOOLS

MACHINERY

EQUIPMENT

MISCELLANEOUS

X

# Alfa Romeo

DIREZIONE ASSISTENZA CLIENTI

DATE

15-1-1964

SEQUENT NUMBER

115

GIULIETTA - GIULIA

2000 - 2600

## Tooling News

### CENTERING OF BRAKE SHOES FOR TURNING THE LININGS

A.4.0117

#### 3-shoe brakes

1

Catch the flange "A" by knurled boss and insert the flange onto the proper side of shaft of the tool A.4.0109, until it comes to stop against the disc with the ribs.

2

Locate the push-rods "B" in a position corresponding to half the length of linings and lock the setscrew "C"

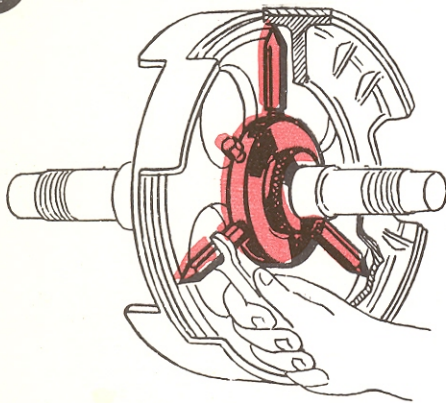

3

Adjust the push-rods "B" until the tapered tips are at a distance from the center approximately equal to the radius of shoe slab inner surface.

4

Install the brake shoes and tighten the push-rods "B" by hand so as to lock the shoes in the tool housings.

5

Further tighten the push-rod "B" of half a turn with a wrench. Avoid excessive tightening as this is useless and can cause the warping of the tool or the breakage of ribs.

#### 2-shoe brakes

6

Remove the setscrew "C" and fit a push-rod "B" in its place. Two push-rods should be aligned; the third one is of no use.

7

Proceed as per 1 - 2 - 3 - 4 - 5.

When the tool A.4.0109 is used, it is possible to center and lock the flange "A" with the setscrew "C". When other tools are used for turning the two-shoe brakes, the flange "A" is not fixed in the center but remains locked only by the action of the two push-rods.

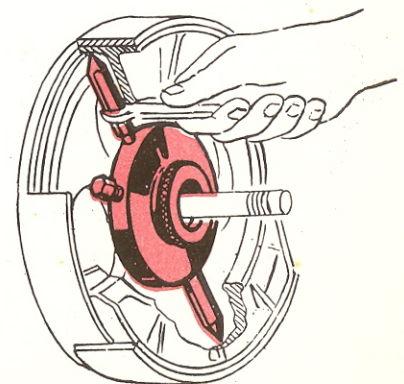
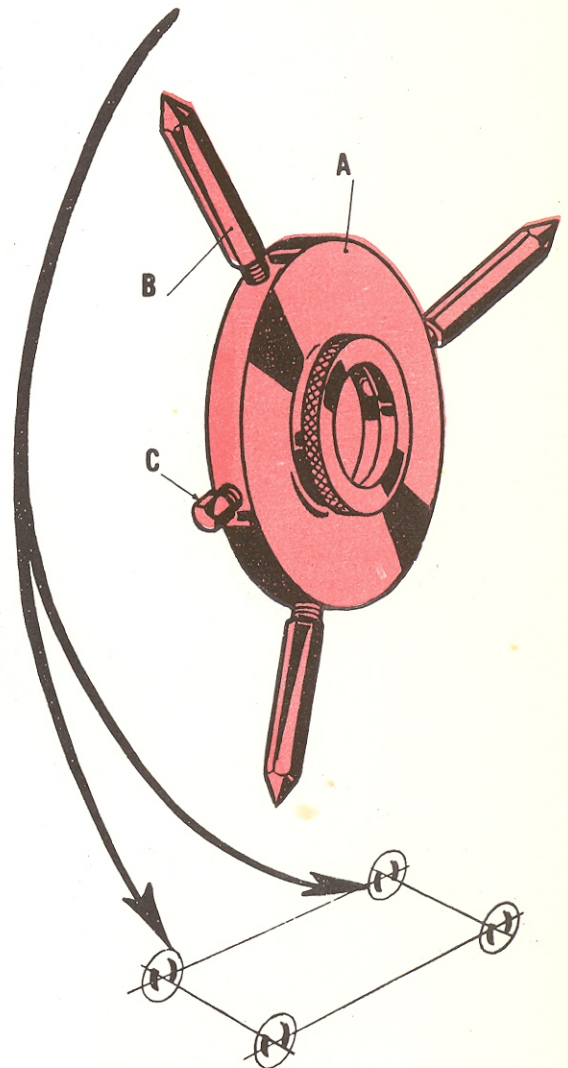

GENERAL TOOLS	
SPECIAL TOOLS	X
MACHINERY	
EQUIPMENT	
MISCELLANEOUS	

# Alfa Romeo

DIREZIONE ASSISTENZA CLIENTI

DATE  
8-9-64

SEQUENT NUMBER  
116

## Tooling News

Giulietta - Giulia

2000 - 2600

### A.2.0144

#### DIFFERENTIAL PINION LOCKING

- 1: Remove the four bolts "A" and rest the tool against the prop. shaft joint flange. The stop "B" must point toward the differential housing and, when fitted, should permit the pinion to swing through a certain extent.

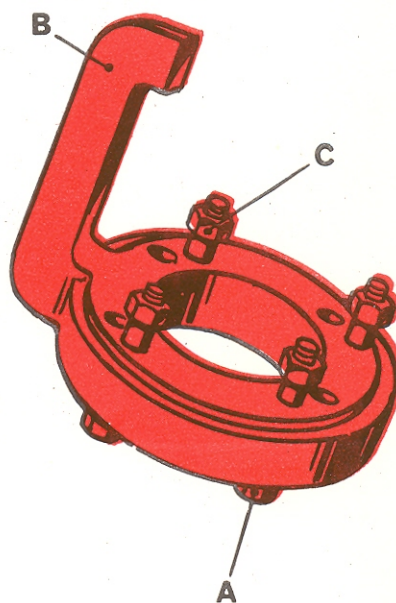
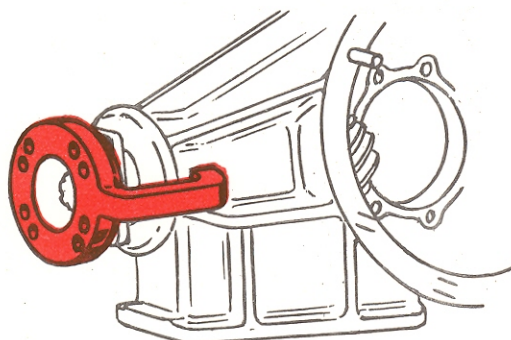

- 2 According to the car model bring four of the holes in the tool into alignment with those in the flange. The two sets of holes differ from one another by diverse chamfers.

- 3 Insert bolts "A" so that thread is toward the differential housing and tighten the nuts "C" only hand held.

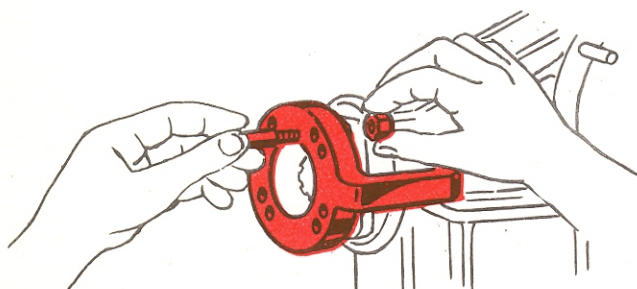

- 4 Remove or refit the pinion as required.
- 5 For removal of tool reverse the procedure described under 1), 2) and 3).

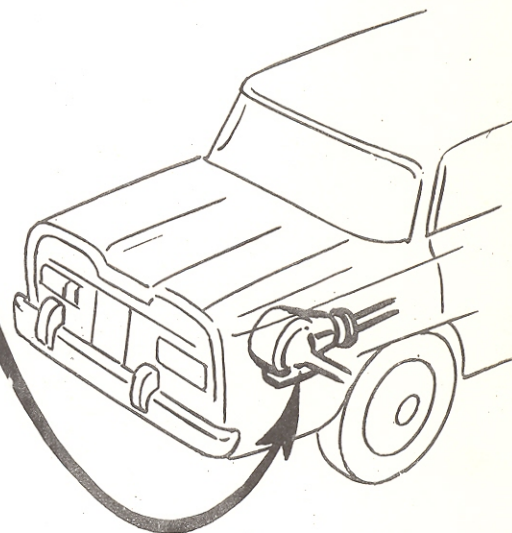

**Note:** This tool as a unit replaces the two previous tools P.N. 6121.01.100 (A.3.0183) and P.N. 6121.01.166 (A.3.0184) which, however, can still be used.

GENERAL TOOLS	
SPECIAL TOOLS	X
MACHINERY	
EQUIPMENT	
MISCELLANEOUS	

*Alfa Romeo*

DIREZIONE ASSISTENZA

*Tool Bulletin*

DATE	28-2-1973
SEQUENT NUMBER	116/2
Giulia - 1750 2000 - Montreal	

## DIFFERENTIAL PINION LOCKING AND RING NUT TIGHTENING

**A.2.0144**  
Giulia - 1750

**A.2.0246**  
2000 - Montreal

### LOCKING THE PINION

- 1 Remove the four bolts "A" and rest the tool against the propeller shaft joint flange.
- 2 The stop "B" must point toward the differential housing and, when fitted, should permit the pinion to rotate through a certain extent.
- 3 According to the car model bring the holes in the tool into alignment with those in the flange.
- 4 Insert bolts "A" so that thread is toward the differential housing and tighten the nuts "C" only hand held.

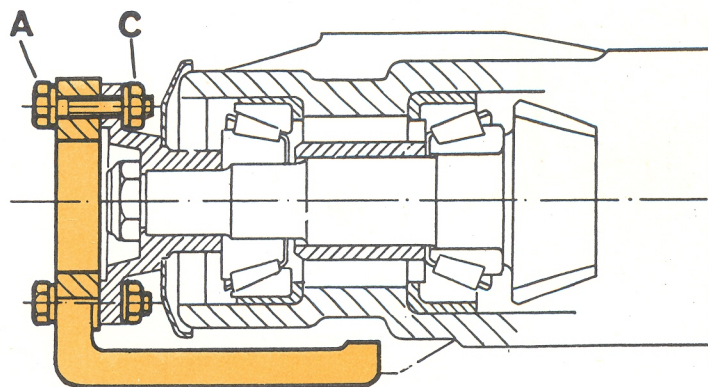
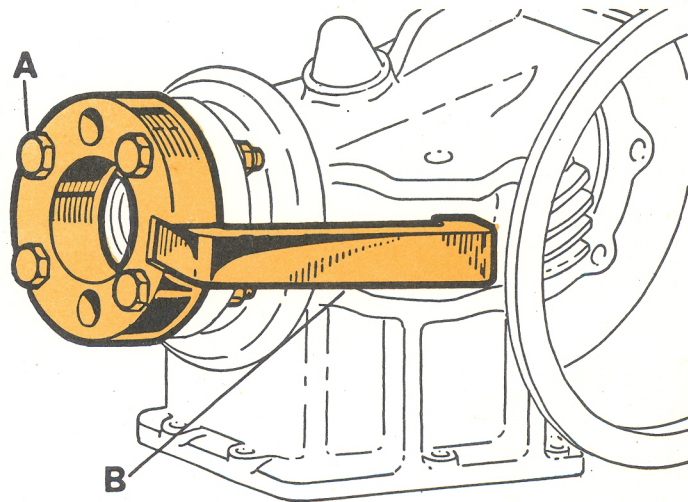

### TIGHTENING THE RING NUT

- 5 Screw in the ring nut and tighten it with the tool A.5.0104 (Giulia & 1750 models) or tool A.5.0114 (2000 models) and a torque spanner. On Montreal model use a 30 mm hex. box spanner.

**A.5.0104 - A.5.0114**

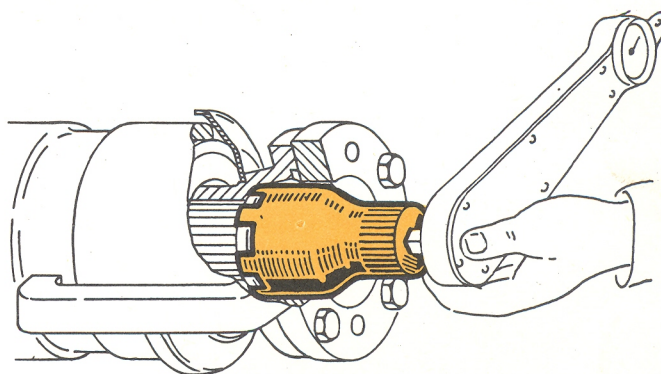

N.B. - For tightening torque specifications refer to the "Technical Characteristics & Inspection Specs" publications.

GENERAL TOOLS

SPECIAL TOOLS

X

MACHINERY

EQUIPMENT

MISCELLANEOUS

# Alfa Romeo

DIREZIONE ASSISTENZA CLIENTI

DATE

25/3/1965

SEQUENT NUMBER

117

Giulietta - Giulia  
2000-2600

## Tooling News

### CHECKING THE T.D.C. FOR TIMING THE ENGINE

### C.6.0122

- 1 Screw the tool by hand into the sparkplug hole in the cylinder no. 1 until the shoulder of the tool contacts the cylinder head.

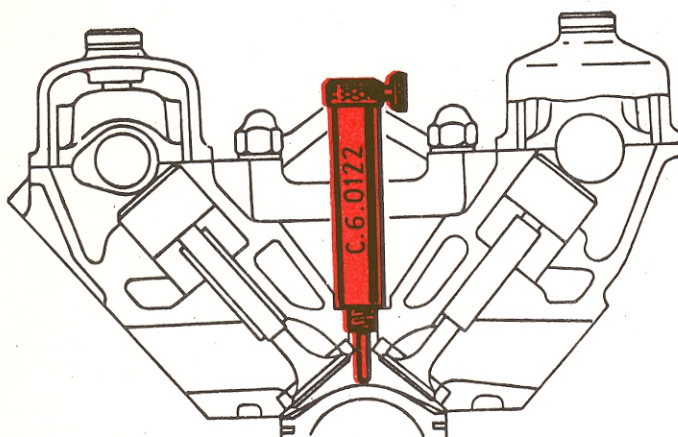

- 2 Fit a dial gauge in the bore "A" and tighten it slightly with the setscrew "B".

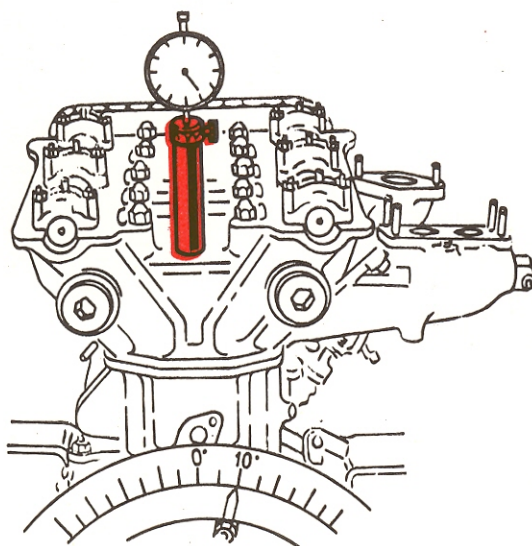

- 3 Rotate the crankshaft to find out the T.D.C. as directed in the Shop Manual.

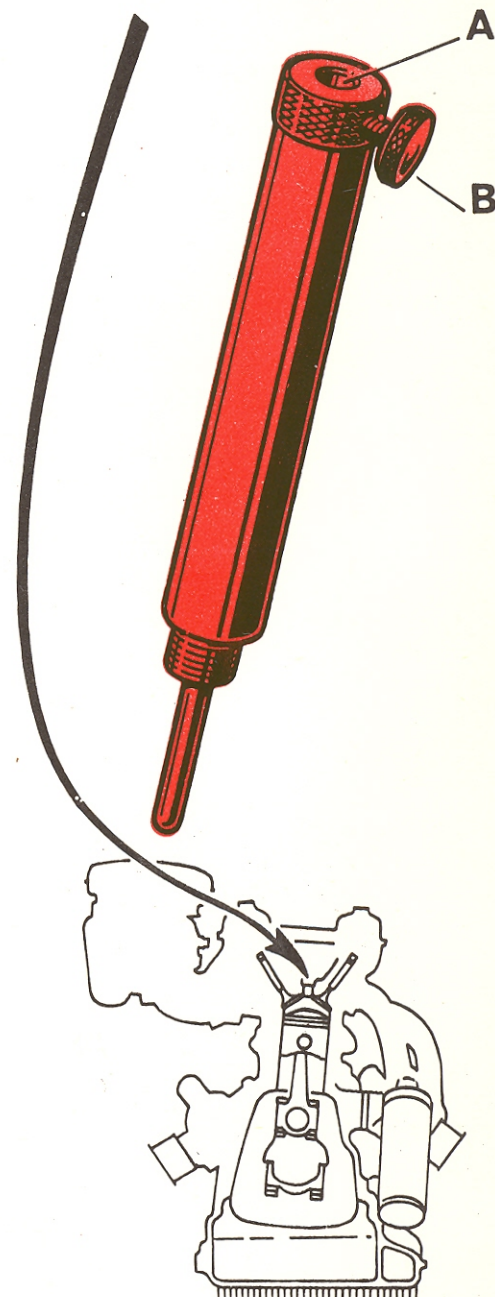

GENERAL TOOLS	
SPECIAL TOOLS	X
MACHINERY	
EQUIPMENT	
MISCELLANEOUS	

# Alfa Romeo

DIREZIONE ASSISTENZA

## Tool Bulletin

DATE

28-2-1973

SEQUENT NUMBER

117/1

Giulia - 1750  
2000 - Montreal  
Alfetta - F 12

### CHECKING THE T.D.C. SETTING FOR TESTING THE ENGINE TIMING

C.6.0122

- 1 Screw the tool by hand into the spark plug hole in the cylinder no. 1 until the shoulder of the tool contacts the cylinder head.
- 2 Fit a dial gauge in the bore "A" and tighten it slightly with the setscrew "B".
- 3 Rotate the crankshaft to find out the T.D.C. as directed in the Shop Manual.

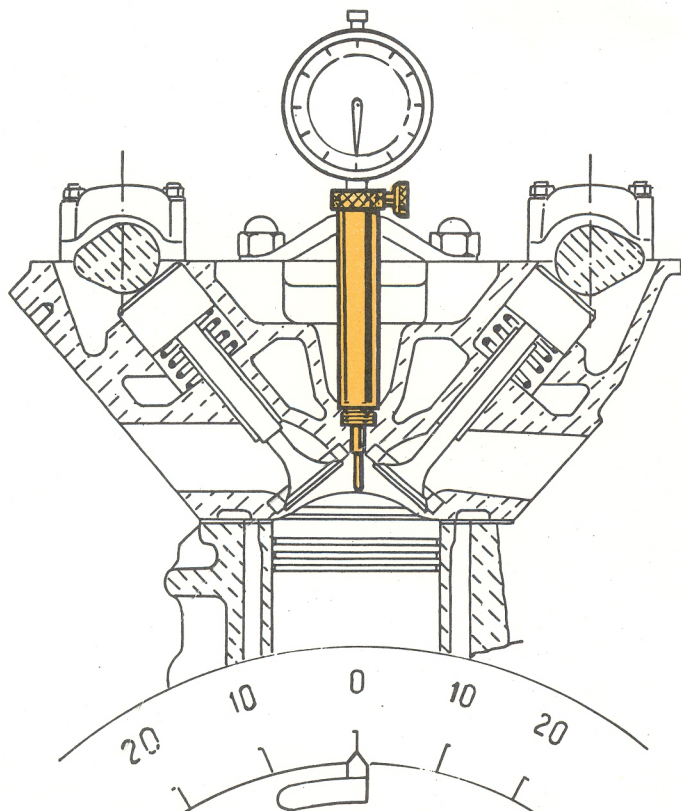
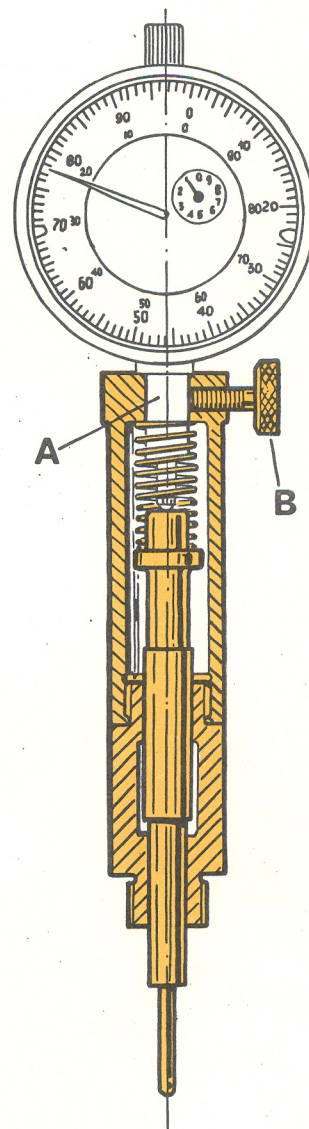

Deletes and supersedes T.B.  
No. 117 dated 25/3/1965

GENERAL TOOLS	
SPECIAL TOOLS	X
MACHINERY	
EQUIPMENT	
MISCELLANEOUS	

# Alfa Romeo

DIREZIONE ASSISTENZA

DATE  
28-4-64

SEQUENT NUMBER  
118

1300 - 1600  
2000 - 2600

## Tooling News

### REMOVING THE VALVE SEAT INSERTS FROM CYLINDER HEAD

A.0.0012

- 1 Assemble the tap and the limit stop of proper diameter (see table below) to the spindle and lock in place with nut "A" and washer "B".

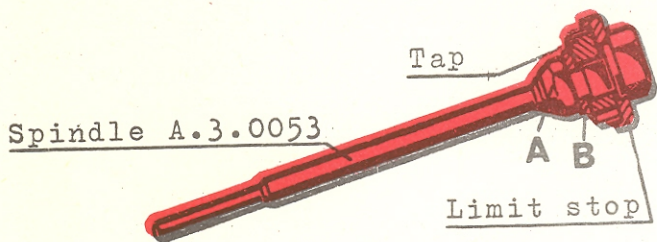

Engine model	Valve seat	Tap P. N.	Limit stop dia. mm
1300	intake	U4.0002	38.5
	exhaust	U4.0001	35
1600	intake	U4.0004	42.5
	exhaust	U4.0002	38.5
2000	intake	U4.0006	48
	exhaust	U4.0005	42.5
2600	intake	U4.0005	44.4
	exhaust	U4.0003	40.4

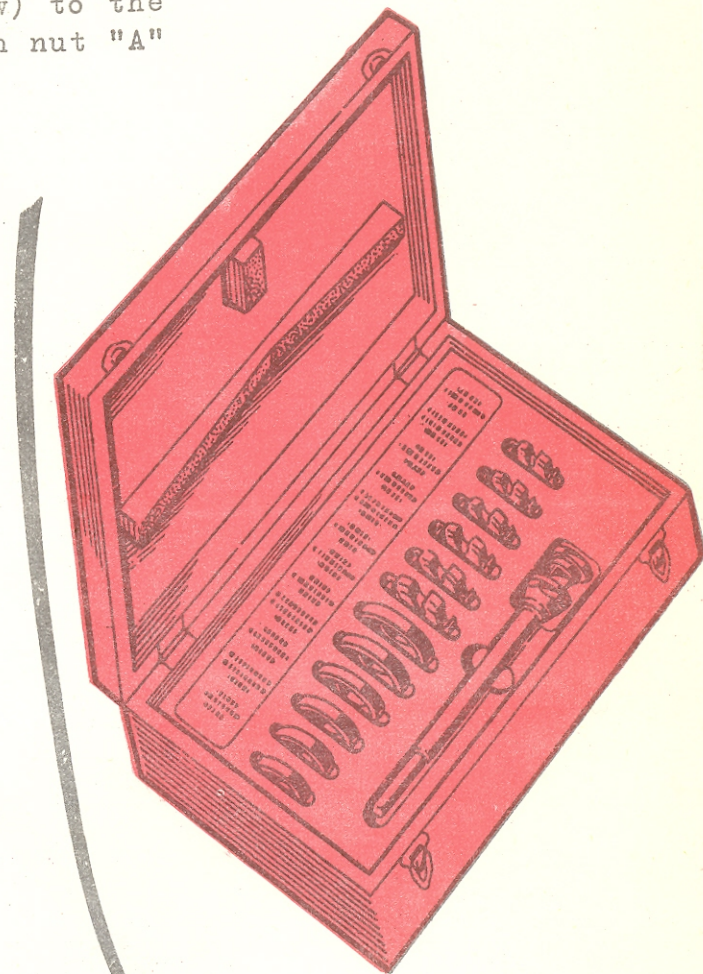

- 2 Set the cylinder head in a vice with the tool A.2.0108.

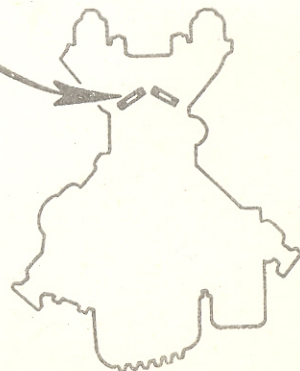
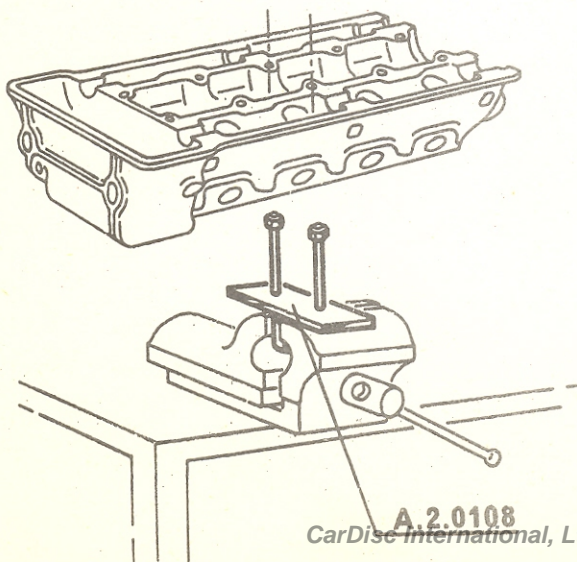

A.2.0108

3

Slide the spindle, assembled as per par. 1, into the valve guide until the tap just contacts the valve seat insert.

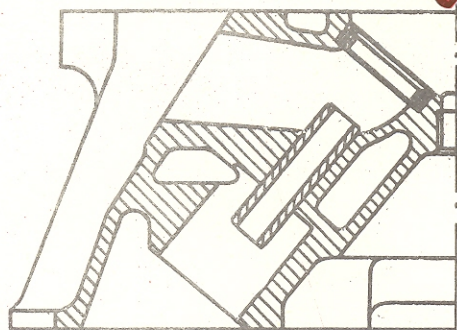

4

With the aid of a 22 mm (7/8") wrench, tap the tool into the valve seat until the limit stop touches the top surface of the seat insert then back off about half a turn.

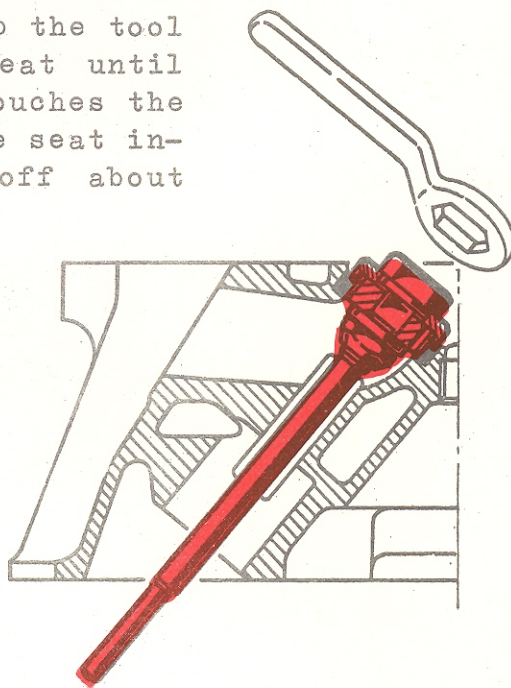

5

With a mallet strike the end of the spindle protruding from the head in order to remove the seat insert.

GENERAL TOOLS	
SPECIAL TOOLS	<b>X</b>
MACHINERY	
EQUIPMENT	
MISCELLANEOUS	

# Alfa Romeo

DIREZIONE ASSISTENZA

## Tool Bulletin

DATE	20-5-1964
SEQUENT NUMBER	119
	2600

### PULLING THE LEVERS OF REACTION TRIANGLE

**A. 3. 0153**

- 1 Remove nut "A" and washer "B" attaching the lever to pin "E".

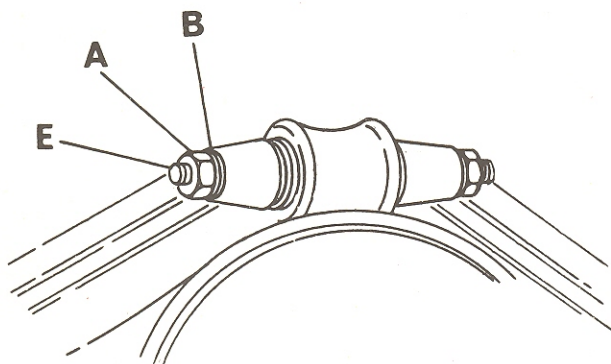

- 2 Apply the puller as shown.

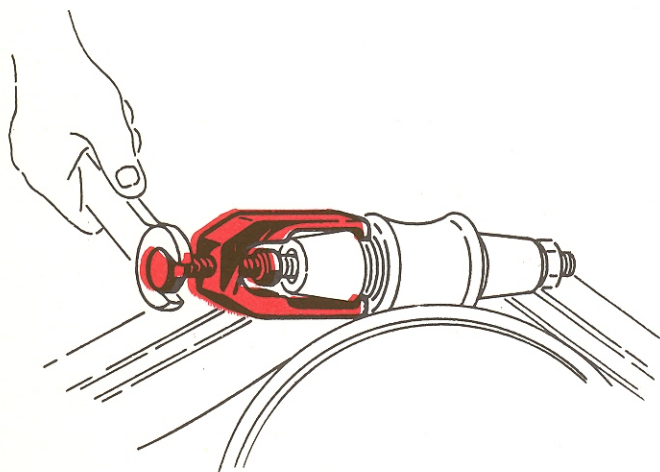

- 3 Have the pad "C" resting against the end of pin "E". With a wrench, rotate screw "D" to pull the lever.

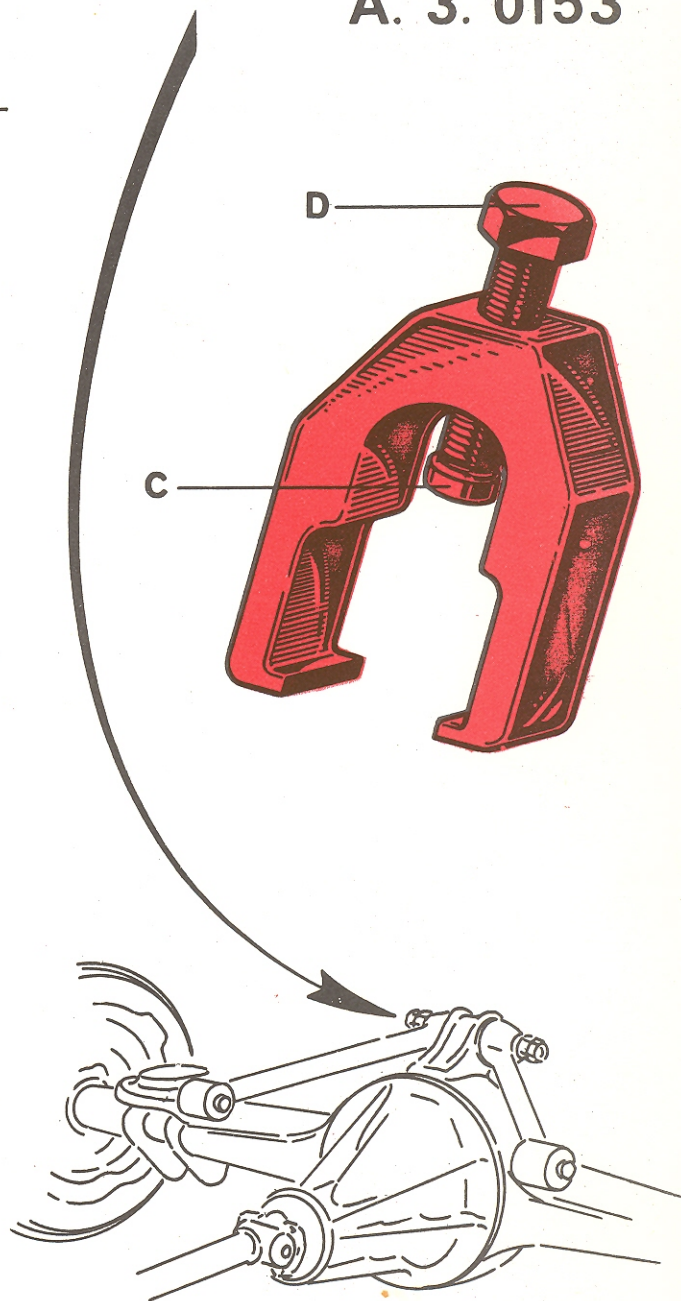

GENERAL TOOLS	
SPECIAL TOOLS	X
MACHINERY	
EQUIPMENT	
MISCELLANEOUS	

# Alfa Romeo

DIREZIONE ASSISTENZA CLIENTI

DATE

9-5-1969

SEQUENT NUMBER

121/2

## Tooling News

Giulietta - Giulia  
1750

### CHASSIS CHECKING

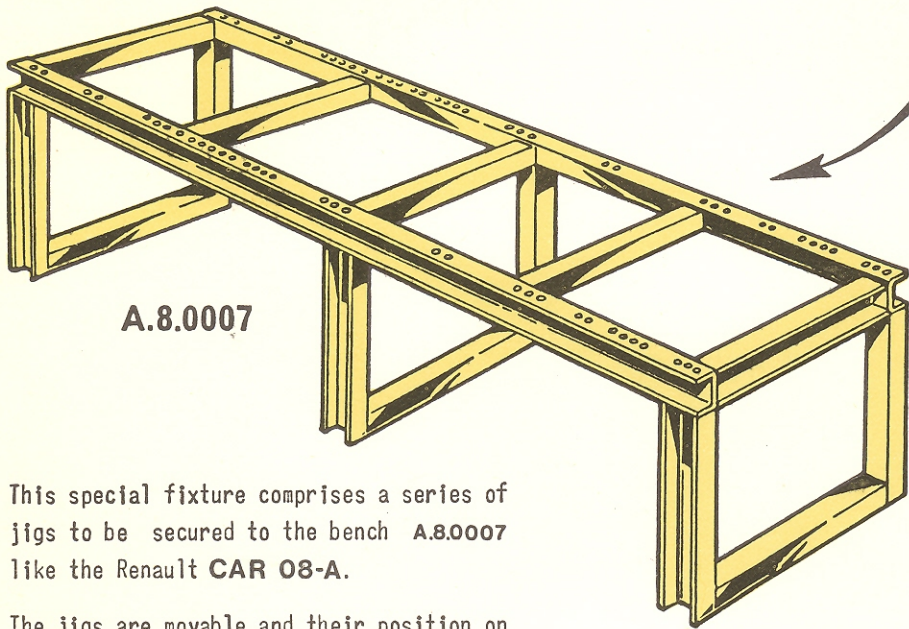

A.8.0007

This special fixture comprises a series of jigs to be secured to the bench A.8.0007 like the Renault CAR 08-A.

The jigs are movable and their position on the bench varies according to the chassis to be checked.

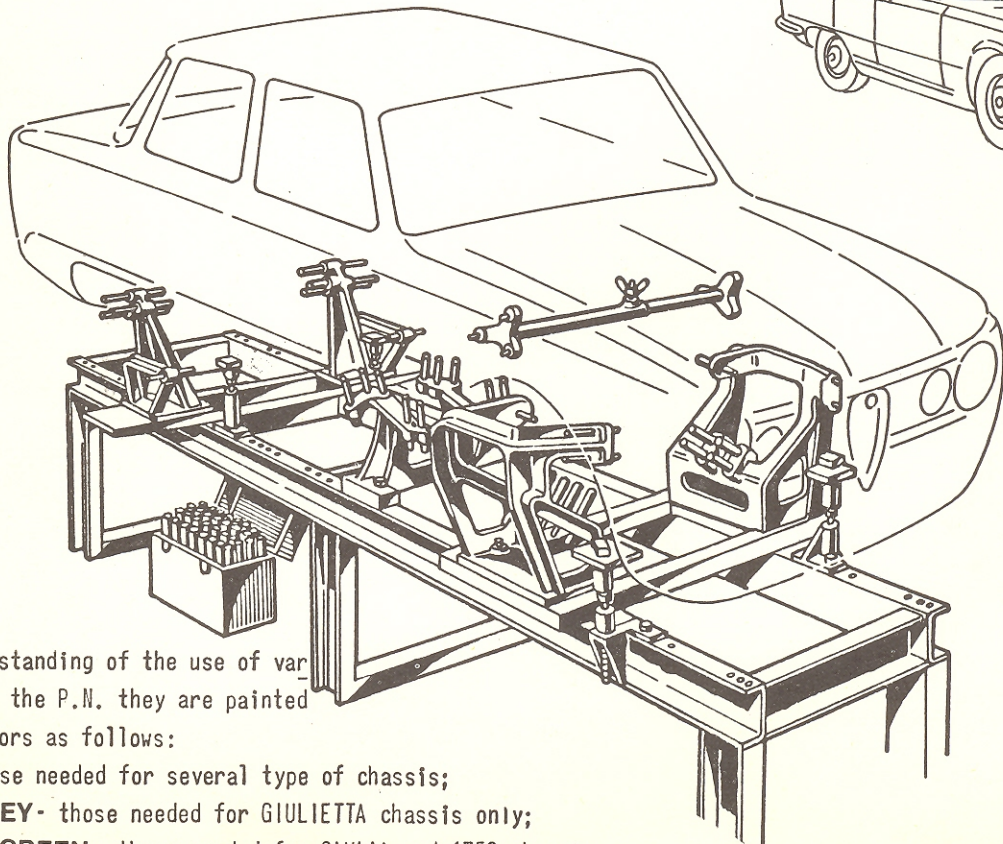

This Bulletin deletes and supersedes the I.B. No. 121 dated 29/8/64

For a best understanding of the use of various jigs beside the P.N. they are painted in different colors as follows:

- GOLD** - those needed for several type of chassis;
- PEARL GREY** - those needed for GIULIETTA chassis only;
- EMERALD GREEN** - those needed for GIULIA and 1750 chassis.

BENCH A.8.0900 for "GIULIETTA" (See list on page 3/6)

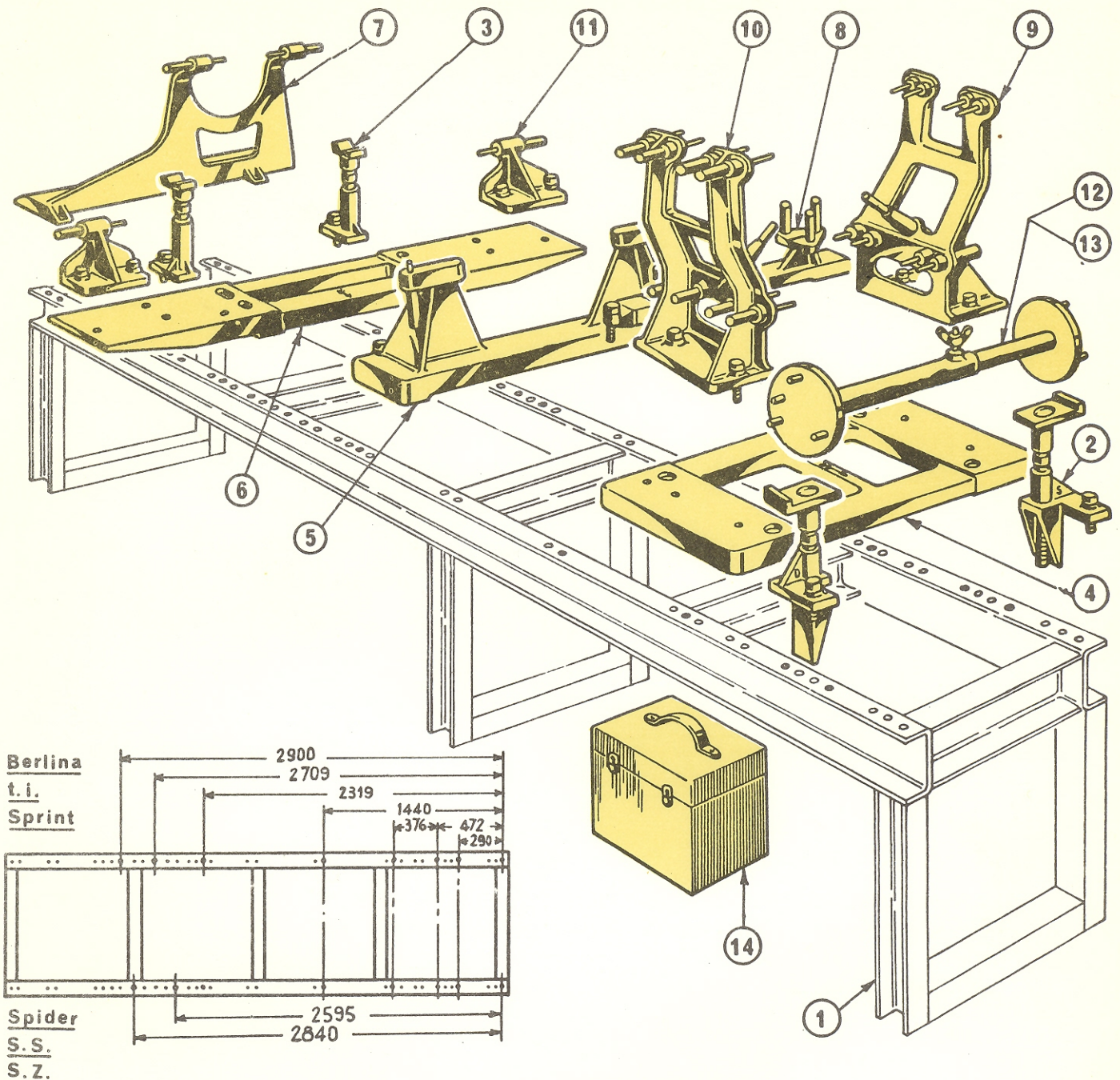

The plan view of the bench 1 above shows the dimensions of jig locating holes. The cross-member 6 should be secured to the bench 1 through the slots marked out with the numbers 101 and 105.03. To check the long chassis (Berlina, t.i., Sprint) or the shorter ones (Spider, SS, SZ) it is enough to shift the rear jigs 11, 3, 7 only.

- The figure shows the jigs 11 in the position suitable for long chassis; for the shorter chassis rotate them by 180°.
- For the screw jacks 3 it is necessary to change locating holes as shown in the plan view.
- For the jig 7 it is necessary to change both the holes in the bench and in the jig itself: as regards the bench holes refer to the plan view; for the holes in the jig use those marked with number 101.00 for long chassis and 101.03 for shorter ones.
- The jigs 8, 9 and 10 should be secured directly to the front plate 4.

The table on the following page list the P.N. and the nomenclature of each component of the fixture assembly required to check the GIULIETTA chassis.

This fixture replaces the tool 6123.91.001 and all the accessories and applies to chassis manufactured after the introduction of the standard gearbox.

List of items for BENCH A.8.0900 (See illustration on page 2/6)

Item No.	P. N.	Nomenclature
1	A.8.0007	Bench (corresponding to the Renault CAR 08-A)
2	A.8.0016	Screw jack for front support of chassis (2 off)
3	A.8.0017	Screw jack for rear support of chassis (2 off)
4	A.8.0008	Front plate for resting of front suspension jigs
5	A.8.0012	Jig for checking the gearbox support cross-member attachment
6	A.8.0013	Cross-member for resting of rear suspension jigs
7	A.8.0015	Jig for checking reaction triangle attachments
8	A.8.0011	Jig for checking attachments of cross-member connecting the front side rails
9	A.8.0009	Jig for checking front suspension attachment and engine mounts, left side
10	A.8.0010	Jig for checking front suspension attachment and engine mounts, right side
11	A.8.0014	Jig for checking the radius rod attachments (2 off)
12	A.8.0025	Telescopic strut for checking steering box & bell-crank attachments (for Berlina and t.i.)
13	A.8.0026	Telescopic strut for checking steering box & bell-crank attachments (for Spider, Sprint, SS, SZ)
14	A.8.0800	Box containing 30 steel dowels as listed below (dowels are not supplied separately, but as a kit):
		A.8.0019 Parallel dowel for front suspension upper arm holes (8 off)
		A.8.0020 Parallel dowel for front suspension lower arm holes (8 off)
		A.8.0021 Parallel dowel for engine mount holes (2 off)
		A.8.0022 Parallel dowel for chassis cross-member holes (6 off)
		A.8.0023 Threaded dowel with nut for gearbox support attachment holes (2 off)
		A.8.0024 Parallel dowel for reaction triangle and radius rod attachment holes (4 off)

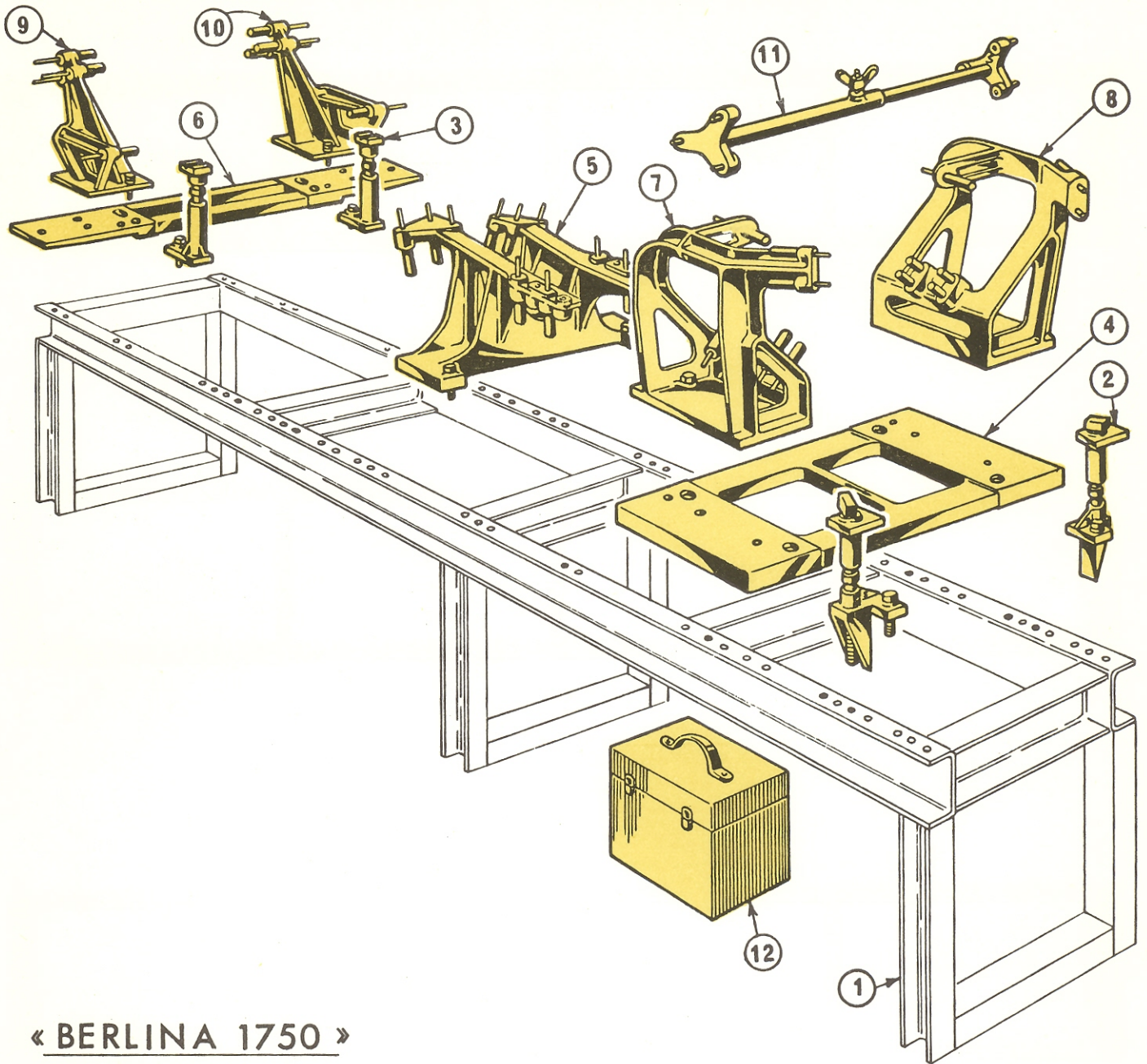

« BERLINA 1750 »

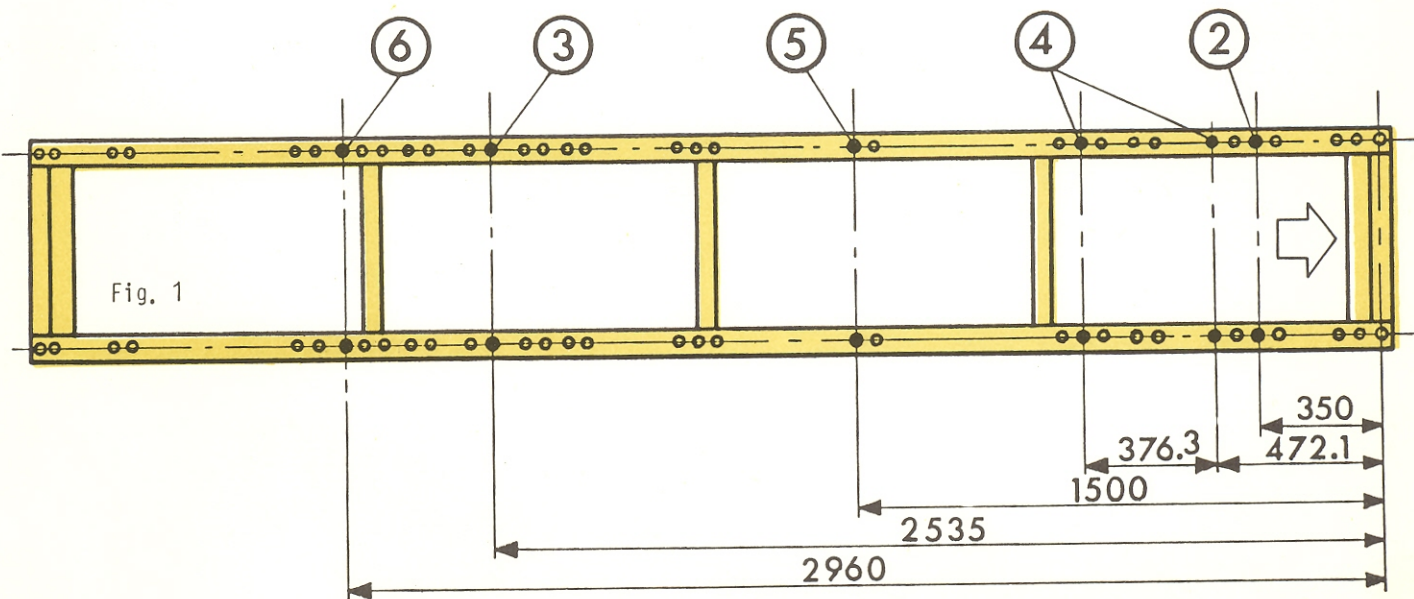

## BERLINE GIULIA (1300-1600)

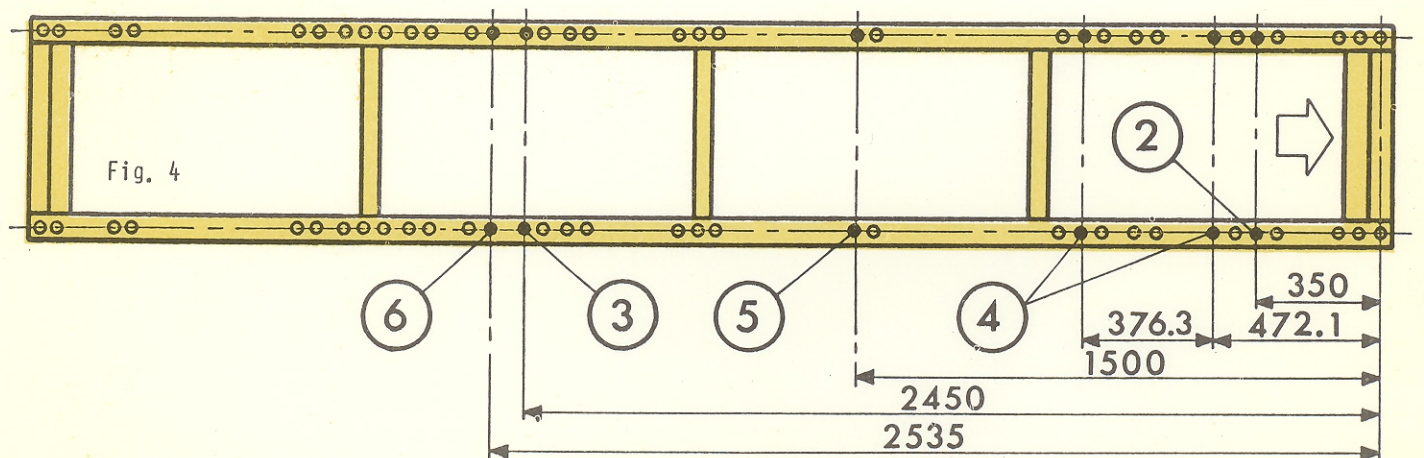
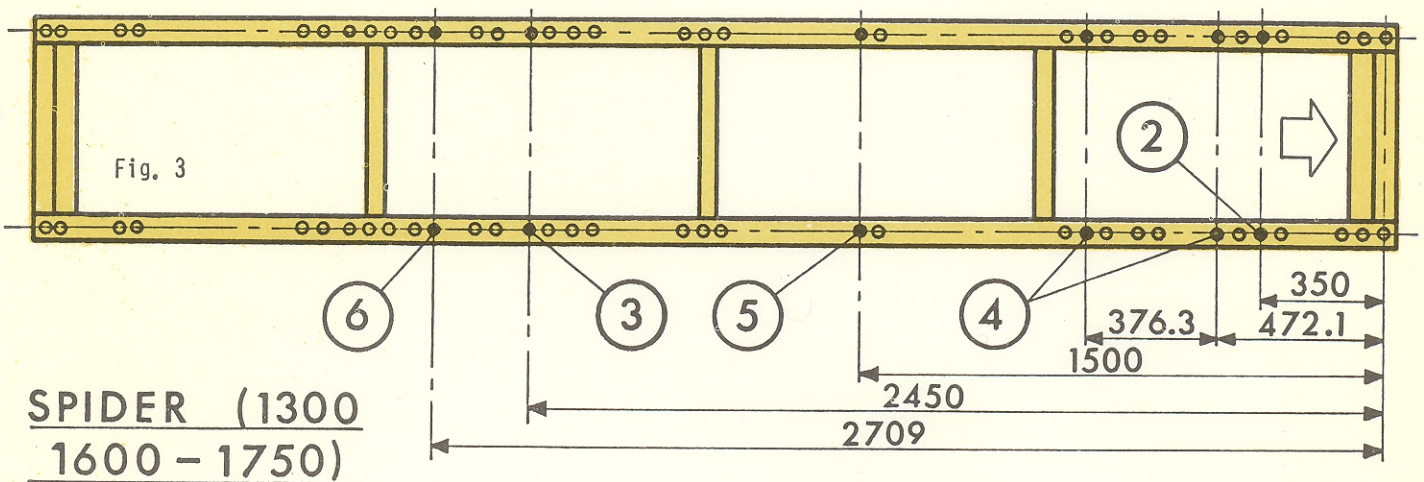
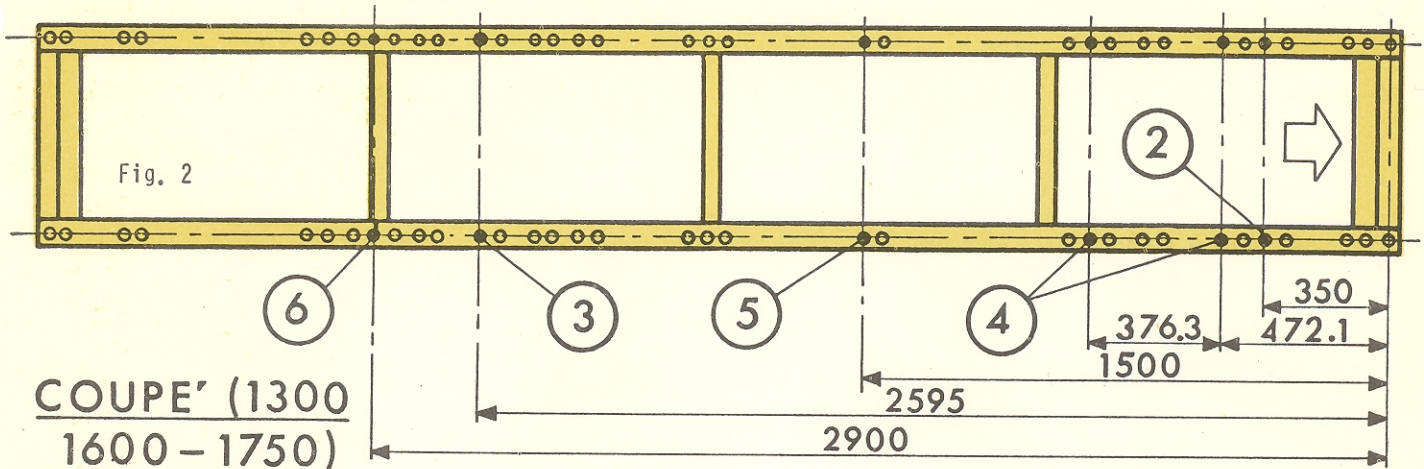

The plan views, fig. 1, 2, 3, 4, show the dimensions of jig locating holes in the bench A.8.0007.

Specifically in the holes:

- at position 2 mount the front jacks A.8.0016 (the one marked "S" on R.H. side and that marked "D" on L.H. side);
- at position 4 mount the front plate A.8.0008.
- at position 5 mount the center jig A.8.0073 for 1750 Berlina and jig A.8.0083 for all other models;
- at position 3 mount the rear jacks A.8.0017.
- at position 6 mount the rear cross-member A.8.0013 to be fixed in the holes marked 105.14 for Berlina-105.02 for Coupe-105.03 for Spider.

List of items for BENCH A.8.0901 (See illustration on page 4/6)

Item No.	P. N.	Nomenclature
1	A.8.0007	Bench (corresponding to the Renault CAR 08-A)
2	A.8.0016	Screw jack for front support of chassis (2 off)
3	A.8.0017	Screw jack for rear support of chassis (2 off)
4	A.8.0008	Front plate for resting of front suspension jig
5a	A.8.0073	Jig for checking gearbox support cross-member and center cross-member attachment (for 1750 Berlina)
5b	A.8.0083	Jig for checking gearbox support cross-member and center cross-member attachment (for all other models)
6	A.8.0013	Cross member for resting of rear suspension jigs
7	A.8.0052	Jig for checking front suspension attachments, right side
8	A.8.0051	Jig for checking front suspension attachment, left side
9	A.8.0054	Jig for checking rear suspension attachments, right side
10	A.8.0055	Jig for checking rear suspension attachment, left side
11	A.8.0056	Telescopic strut for checking steering box & bell-crank attachments
12	A.8.0801	<p>Box containing 28 steel dowels as listed below (dowels are not supplied separately, but as a kit):</p> <p>A.8.0057 Parallel dowel for holes of lower arm of front suspension (2 off) (for Giulia chassis preceding the 68 model)</p> <p>A.8.0059 Parallel dowel for hole of transverse rod of front suspension upper arm (2 off)</p> <p>A.8.0060 Threaded dowel, 8 off:  <ul style="list-style-type: none"> <li>- 4 of which for the hole in slanting rod of front suspension upper arm</li> <li>- 4 of which for gearbox attachment holes</li> </ul> </p> <p>A.8.0061 Threaded dowel for center cross-member attachment holes (6 off)</p> <p>A.8.0062 Parallel dowel for radius rod attachment holes (2 off)</p> <p>A.8.0063 Parallel dowel for T-arm attachment holes (6 off)</p> <p>A.8.0064 Parallel dowel for holes of lower arm of front suspension (8 off) (for Chassis from 68 model up)</p>

GENERAL TOOLS	
SPECIAL TOOLS	X
MACHINERY	
EQUIPMENT	
MISCELLANEOUS	

## Tooling News

### CHECKING THE VALVE CLEARANCE

**C.6.0123**

- 1 Loosen the setscrew "A".
- 2 Slide the rod "B" until the feeler gauge "S" projects from the stub "P" of an amount equal to half the outside diameter of the cup (measure carefully with a vernier caliper).

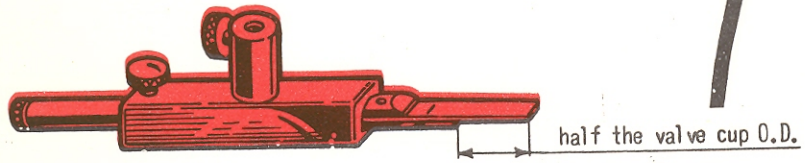

- 3 Lock the setscrew "A".
- 4 Fit a standard dial gauge into the hole "C" and lock in place with the setscrew "D". Set the pointer to the reference reading corresponding to 30 hundredths of a millimeter (.0118").

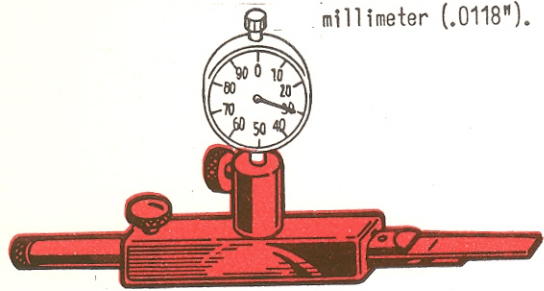

- 5 Unlock the setscrew "A". Rest the end of the stub "P" against the edge of valve cup and slide the feeler gauge "S" until it just contacts the cam.

- 6 The reading on the dial gauge represents the clearance between cup and cam.

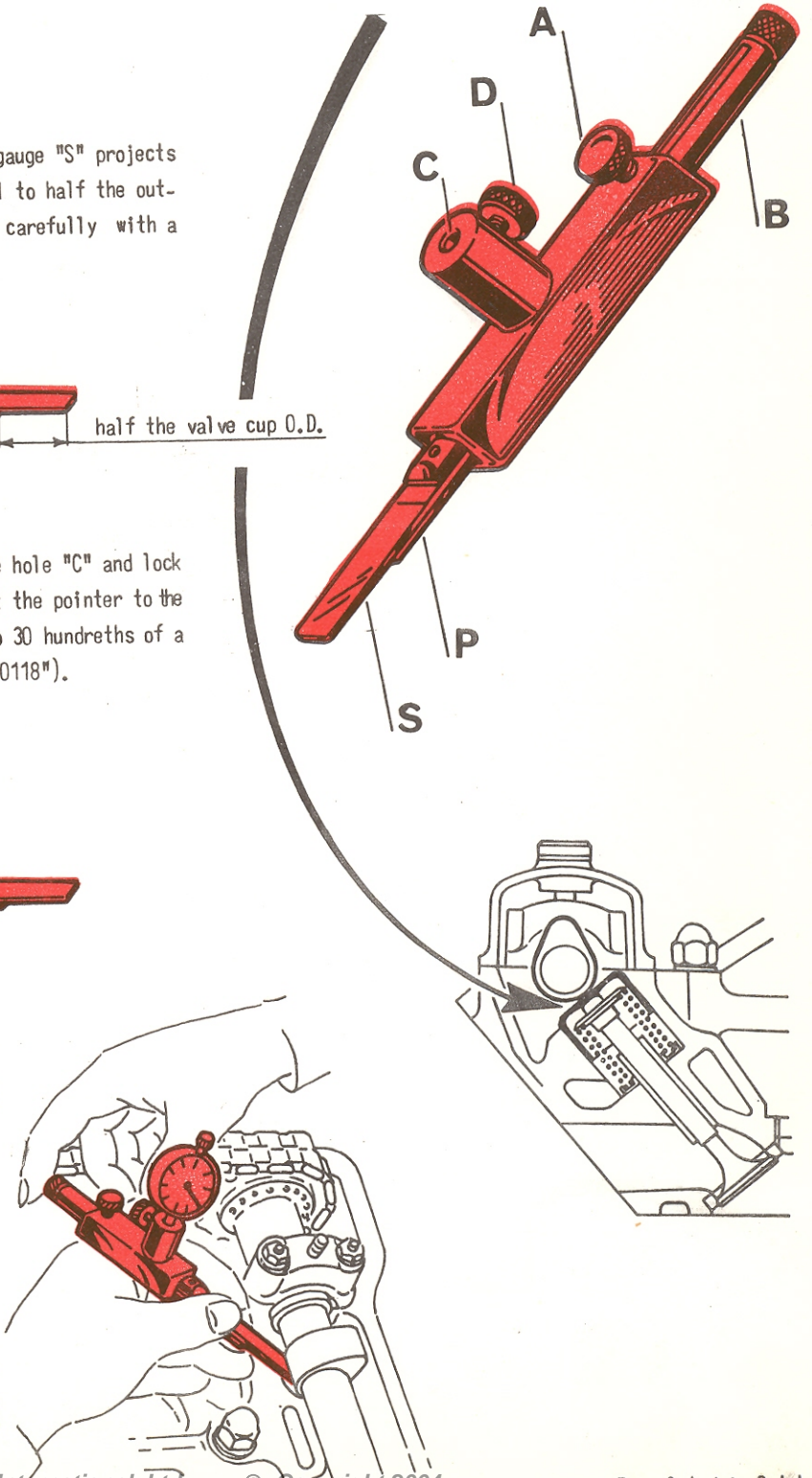

GENERAL TOOLS

SPECIAL TOOLS

X

MACHINERY

EQUIPMENT

MISCELLANEOUS

# Alfa Romeo

DIREZIONE ASSISTENZA

## Tool Bulletin

DATE

18-6-1966

SEQUENT NUMBER

127

Giulia

### TOOL FOR SCRIBING REFERENCE MARKS ON FRONT CAPS OF CAMSHAFTS

### C.6.0124

- 1 Unscrew "A" and fit the cap on tool so that cap is in contact with flats "B" and dowel bushings match holes "C".



- 2 Align pointer "D" with the specified angle value and lock "A" by hand.

WARNING: the angle for intake side is symmetrical to that for exhaust side.

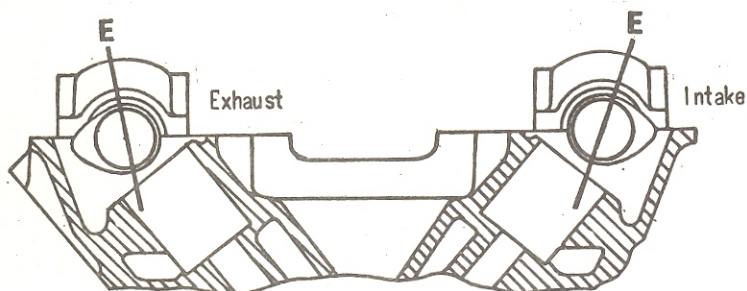

- 3 Scribe reference marks along lines "E".

- 4 Remove cap from tool and cut reference marks deeply.

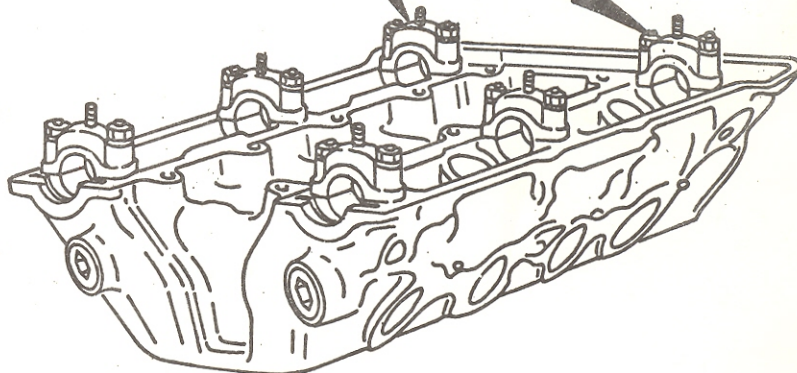
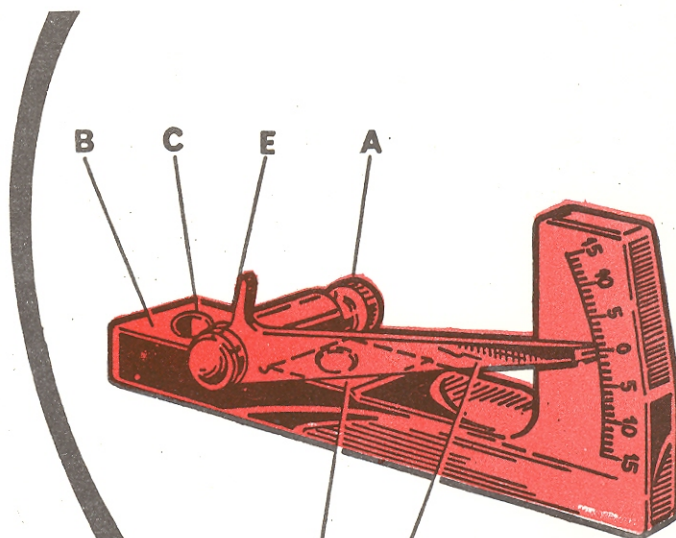
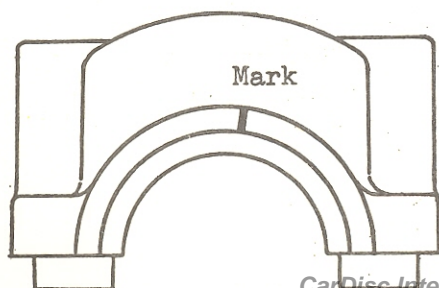

GENERAL TOOLS

SPECIAL TOOLS

X

MACHINERY

EQUIPMENT

MISCELLANEOUS

# Alfa Romeo

DIREZIONE ASSISTENZA

## Tool Bulletin

DATE

28-9-1966

SEQUENT NUMBER

131

Giulietta - Giulia  
2600

### LOOSENING AND TIGHTENING THE IGNITION SWITCH RING NUT

### A.2.0152

- 1 Loosen handle "A" and fit or remove adapter "B" according to the size of ring nut.
- 2 Apply the tool on ring nut as shown and tighten the handle "A" by hand.

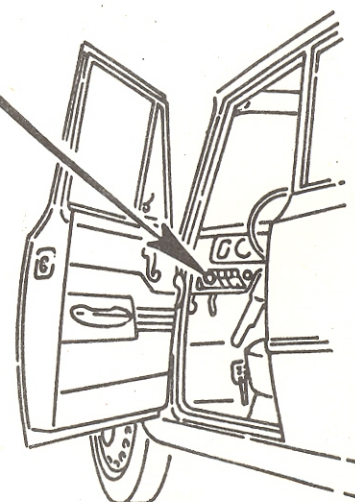
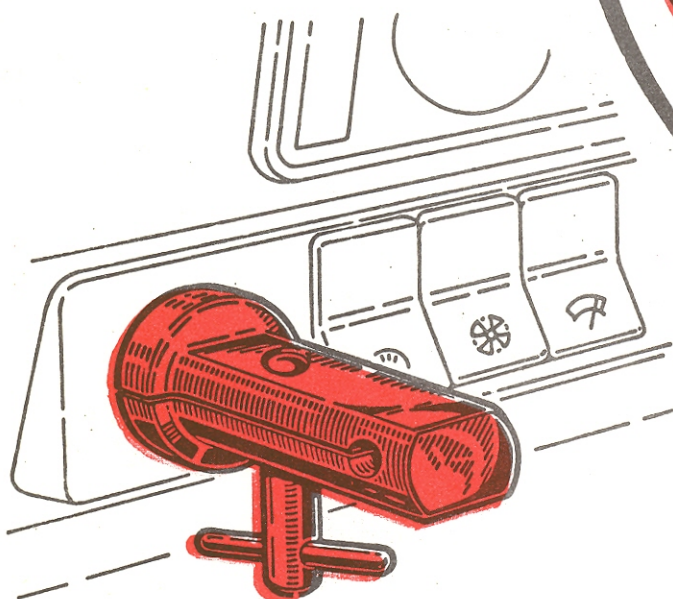
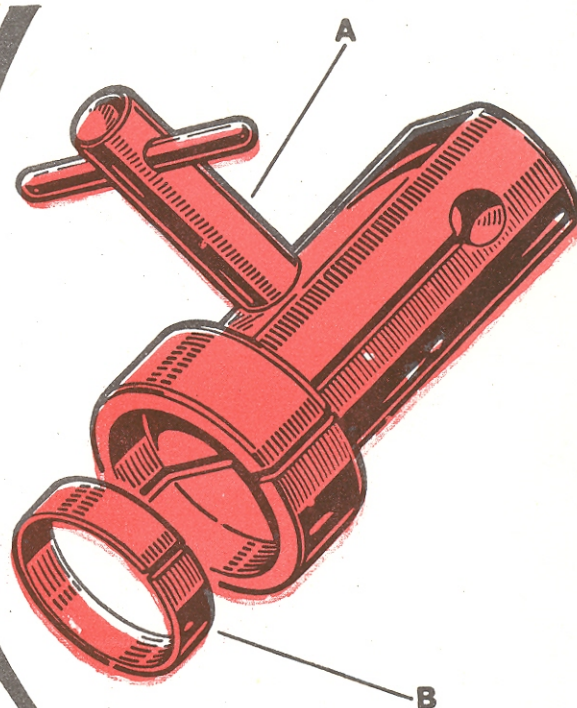

- 3 Loosen or tighten in place the ignition switch ring nut as required.

GENERAL TOOLS	
SPECIAL TOOLS	<b>X</b>
MACHINERY	
EQUIPMENT	
MISCELLANEOUS	

# Alfa Romeo

DIREZIONE ASSISTENZA CLIENTI

DATE

18-3-1969

SEQUENT NUMBER

**132/1**

## Tooling News

Giulia - 1750

### CHECKING THE FRONT SUSPENSION "TRIM"

**C.6.0125**

- 1** Mount the tabs as applicable on the rods of the tool

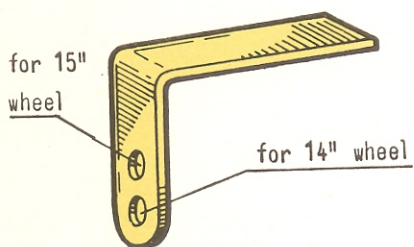

- 2** Screw the nut "C" and then the rod "B" on the rod "A". The clamps "E" should be parallel each other and both setscrews "H" should be on the same side. Surfaces "D" of the tabs should lie on the same plane. Check that the clamps are about 525 mm apart and lock in place the nut "C"

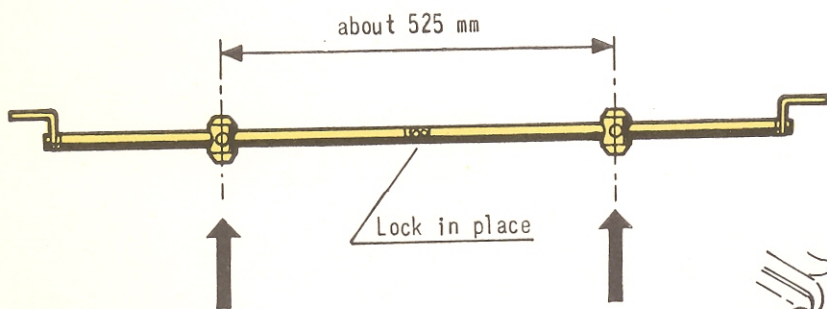
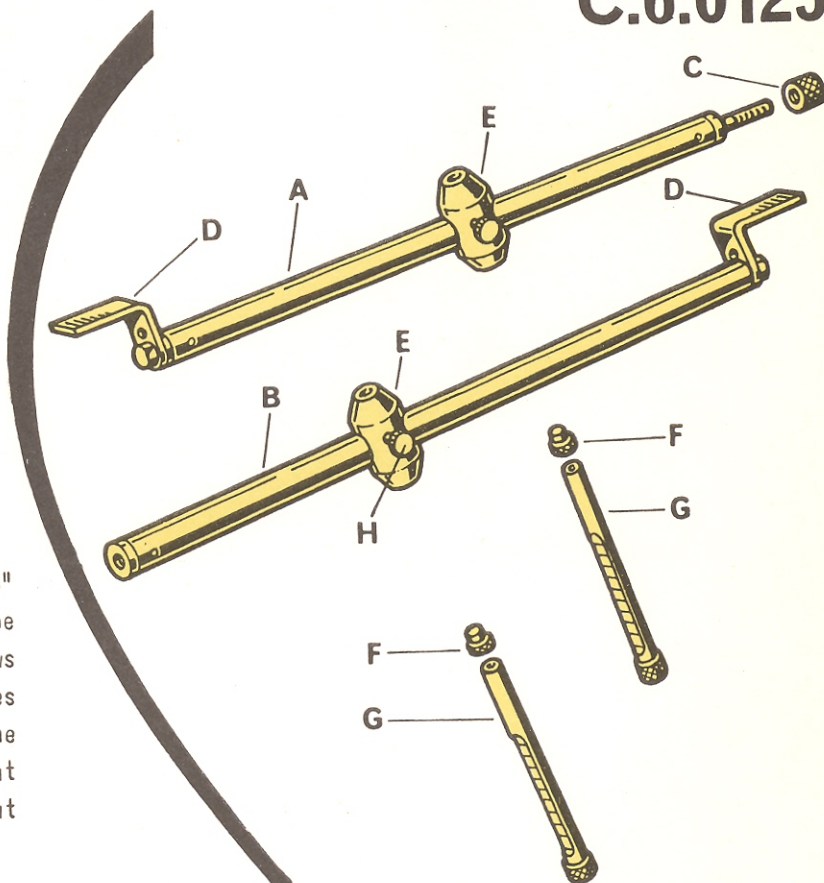

- 3** Remove the pads "F" and insert the rules "G" into clamps "E" in the direction shown by the arrows. Refit the pads "F". The setscrews "H" can lock rules "G" in whatever position

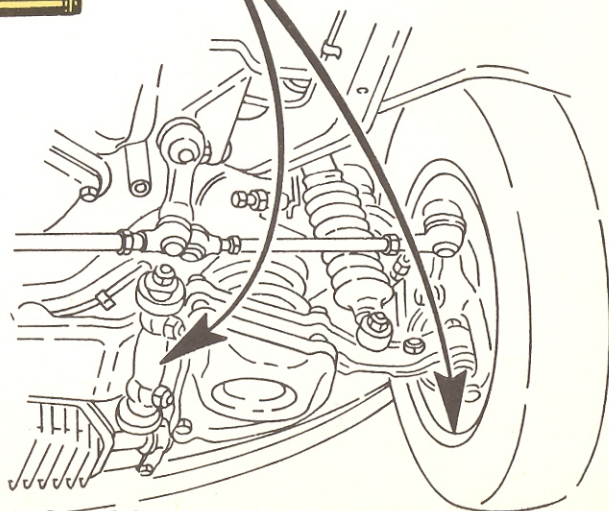

This Bulletin deletes and supersedes the I.B. no. 132 dated 10/1/1967

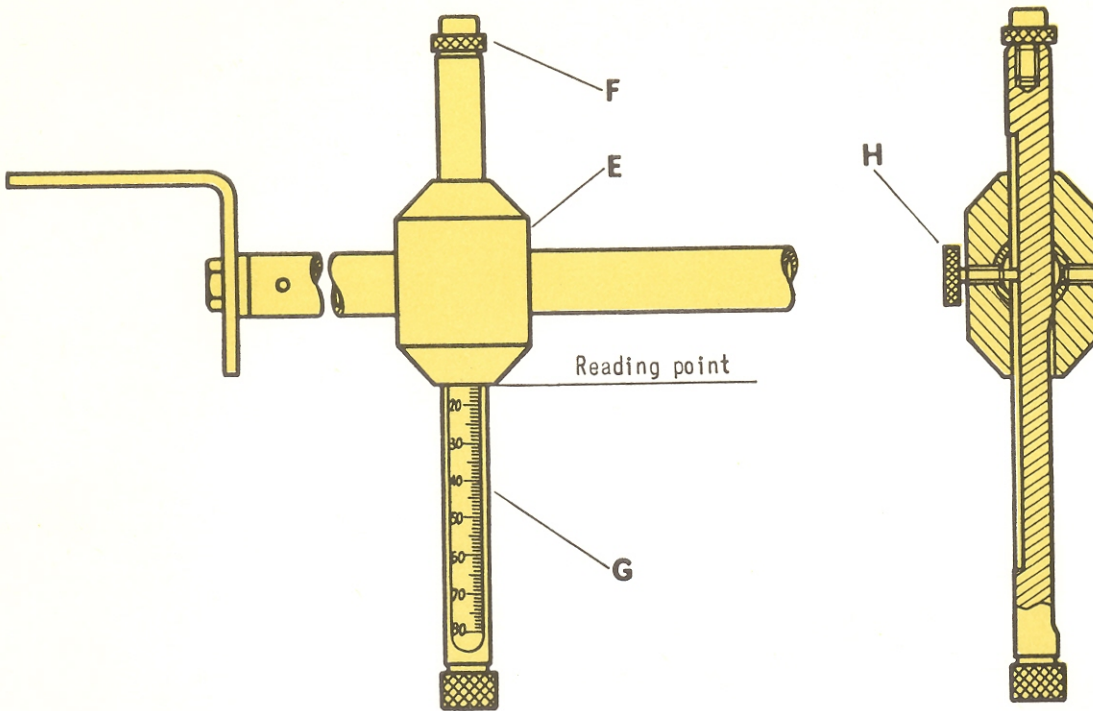

- 4 Bring the rules "G" downward and place the tool under the car in such a way that the two tabs rest against the lower edge of wheel rim as shown

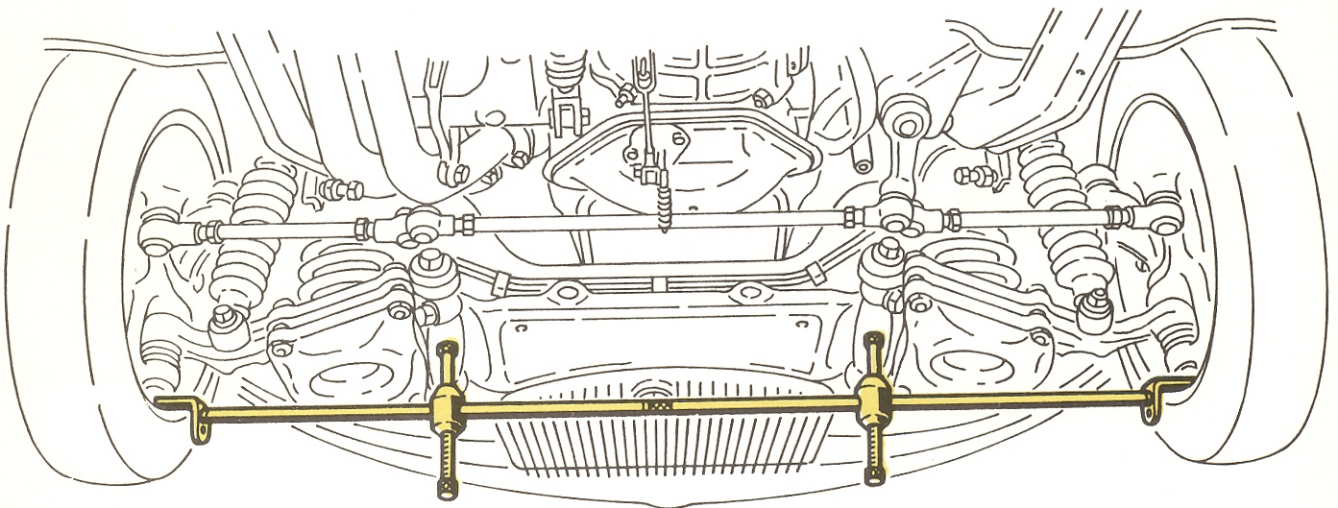

- 5 Slide the rules "G" upward to take the readings which represent the actual values of suspension "trim". The readings must be taken in correspondence of the bottom edge of clamps "E" as shown

GENERAL TOOLS		 DIREZIONE ASSISTENZA CLIENTI  <i>Tooling News</i>	DATE 4-4-1969
SPECIAL TOOLS	X		SEQUENT NUMBER 134/1
MACHINERY			Giulia - 1750 2600
EQUIPMENT			
MISCELLANEOUS			

## STANDARD LOTS OF SPECIAL TOOLS

The following sheets list the items included in each lot of special tools to be used when performing repair works on

GIULIA and 1750 models

Most of the special tools already existing for 1600 models are also applicable to 1750 models; however some of them have been re-designed so that they are now applicable to both range of models in order to limit to a minimum the number of special tools needed.

The tools are grouped together into three lots as follows:

### LOT "A"

To be purchased by Authorized Workshops; it includes: tools strictly required for performing minor overhaul and specially designed to speed up the servicing and maintenance of cars.

### LOT "B"

To be purchased by all Selling Agents, it includes: tool strictly required for performing repair work on any component or main unit.

### LOT "C"

Recommended to large Agents, it includes special tools particularly suitable to facilitate and speed up the reconditioning work.

N.B. - Complementary lots A, B and C for 2600 models have been added to those mentioned above; such lots can be purchased optionally according to the number of cars of the said model circulating in the area.

The tools are listed under the main unit they pertain to, each item bearing the tool number, the applicability to car model, the description and in the last column, as a reference only, the unit price.

This T.B. deletes and supersedes any other list in any previous publication

## STANDARD LOT "A" OF SPECIAL TOOLS for GIULIA and 1750 models

Tool No.	Applies to		Description	Price
	Giulia	1750		
<u>ENGINE</u>				
A.2.0108/1	o	o	Tool for cylinder head support in a vice	5,600
A.2.0117	o	o	Tool (set of two) for retaining cylinder barrels	1,000
A.2.0146	o	o	Tool for removing the head from cylinder block	2,000
A.3.0103/1	o	o	Lever	2,000
A.3.0103/2	o	o	Support	1,500
A.3.0103/6	o	o	Retainer	1,000
			} tools for removing the valve cotters	
A.3.0113	o	o	Tool for driving rubber plugs into crankcase	5,400
A.3.0139/1	o	o	Lever	1,800
A.3.0139/2	o	o	Bracket	1,200
			} tools for removing the rear main bearing cap	
A.3.0146	o	o	Driver of oil seal ring into front cover	1,500
A.3.0178	o	o	Driver of rear crankshaft oil seal ring	3,800
A.5.0106	o	o	Wrench for oil filter and for gearbox/differential oil drain plugs	1,250
A.5.0115	o	o	Adapter, spark plugs-to-torque wrench	800
A.5.0126	o	o	Wrench for crankshaft pulley nut	1,600
C.5.0111/1	o	o	Support for valve adjusting pad selection	3,200
C.6.0123	o	o	Feeler gauge for checking valve clearance	11,000
<u>PROPELLER SHAFT</u>				
A.5.0162	o	o	Wrench for flexible and U-joints	1,600
<u>REAR AXLE - DIFFERENTIAL</u>				
A.2.0144	o	o	Tool for stopping pinion	3,500
A.3.0109	o	o	Puller of axle shafts and puller-driver of axle shaft bearings and front wheel hubs	15,700
A.3.0109/1	o	o	Tool for resting the pins of puller A.3.0109 for withdrawal of disc-brake axle shaft	4,300

Tool No.	Applies to		Description	Price
	Giulia	1750		
A.3.0160	o	o	Driver of oil seal ring into axle tubes	1,100
A.3.0167	o	o	Driver of oil seal ring onto pinion	2,000
A.5.0104	o	o	Wrench for pinion yoke ring nut	2,200
<u>FRONT AND REAR SUSPENSIONS</u>				
A.2.0169	o	o	Tool for removing front suspension springs	16,800
A.2.0178	o	o	Driver of bolt into rear trailing arm	800
A.3.0156	o	o	Puller of upper pin from stub axle	3,400
A.3.0157	o	o	Puller of lower pin of stub axle and ball joints	3,900
A.3.0243	o	o	Tool for removing and installing rubber bushings of stabilizer rod links	2,300
A.5.0161	o	o	Wrench for tightening front cross-member bolts	1,100
<u>"ATE" BRAKES</u>				
A.2.0147	o	o	Tool for resetting brake pistons	3,000
A.2.0148/1	o	o	Pliers for rotating rear brake pistons	2,000
A.2.0149	o	o	Template for positioning brake pistons	800
A.2.0150	o	o	Puller of friction pads	1,000
A.2.0151	o	o	Tool for checking brake disc squareness	2,200
A.2.0159	o	o	Pliers for rotating front brake pistons	2,200
A.2.0160	o	o	Template for positioning brake pistons	800
<u>WHEELS</u>				
A.3.0116	o	o	Driver of wheel hubs onto stub axles	2,250
A.3.0192	o	o	Driver of front wheel packing	1,700
C.5.0117	o	o	Support of dial gauge for checking wheel bearing clearance	9,000

Tool No.	Applies to		Description	Price
	Giulia	1750		
			<u>STEERING GEAR AND LINKAGE</u>	
A.3.0119	o	o	Puller of steering arm	4,700
A.3.0158/1	o	o	Puller of steering wheel (1300 - T.I. - G.T.)	1,900
A.5.0154	o	o	Wrench for steering column jacket screws (3-4-5 mm hex)	1,200

## STANDARD LOT "B" OF SPECIAL TOOLS

### for GIULIA and 1750 models

Tool No.	Applies to		Description	Price
	Giulia	1750		
			<u>ENGINE</u>	
A.2.0108/1	o	o	Tool for cylinder head support in a vice	5,600
A.2.0117	o	o	Tool (set of two) for retaining cylinder barrels	1,000
A.2.0121	o	o	Tool for supporting valves in cylinder head	1,250
A.2.0145	o	o	Tool for locking the flywheel	2,650
A.2.0146	o	o	Tool for removing the head from cylinder block	2,000
A.2.0152	o		Tool for tightening ignition switch ring nuts	1,200
A.3.0103/1	o	o	Lever	2,000
A.3.0103/2	o	o	Support	} tools for removing the valve cotters
A.3.0103/6	o	o	Retainer	
A.3.0113	o	o	Tool for driving rubber plugs into crankcase	5,400
A.3.0133	o	o	Driver of exhaust valve guides	1,200
A.3.0134	o	o	Puller of valve guides from cylinder head	1,200
A.3.0139/1	o	o	Lever	} tools for removing the rear main bearing cap
A.3.0139/2	o	o	Bracket	
A.3.0146	o	o	Driver of oil seal ring into front cover	1,500
A.3.0147	o	o	Puller of water pump pulley	2,550
A.3.0177	o	o	Driver of water pump sealing ring	1,700
A.3.0178	o	o	Driver of rear crankshaft oil seal ring	3,800
A.3.0182	o	o	Tool for removal of main bearing caps	5,800
A.3.0210	o	o	Puller	} timing chain idler sprocket bushing Crankshaft rear bushing oil pressure relief valve
A.3.0244	o	o	Driver of valve guide seals	1,000
A.3.0246	o	o	Driver of intake valve guides	1,150
A.3.0247	o	o	Puller of valve guide seals	3,500
A.5.0103	o	o	Wrench for turning camshafts	2,000
A.5.0106	o	o	Wrench for oil filter and for gearbox/differential oil drain plugs	1,250
A.5.0115	o	o	Adapter, spark plugs-to-torque wrench	800

Tool No.	Applies to		Description	Price
	Giulia	1750		
A.5.0126	o	o	Wrench for crankshaft pulley nut	1,600
C.5.0111/1	o	o	Support for valve adjusting pad selection	3,200
C.6.0122	o	o	Tool for checking the T.D.C.	5,800
C.6.0123	o	o	Feeler gauge for checking valve clearance	11,000
<u>CLUTCH</u>				
A.4.0103	o	o	Spindle for clutch disc centering	1,700
<u>STANDARD GEARBOX</u>				
A.3.0118	o	o	Puller-driver of rubber bushing	6,900
A.3.0180	o	o	Driver of oil seal ring into rear cover	1,800
A.3.0185	o	o	Clamp for retaining mainshaft	4,700
A.3.0212	o	o	Puller of differential bearings and outer race of gearbox rear cover	5,000
A.5.0127	o	o	Wrench for securing output shaft yoke	1,200
<u>PROPELLER SHAFT</u>				
A.5.0162	o	o	Wrench for flexible and U-joints	1,600
<u>REAR AXLE - DIFFERENTIAL</u>				
A.2.0144	o	o	Tool for stopping pinion	3,500
A.3.0109	o	o	Puller of axle shafts and puller-driver of axle shaft bearings and front wheel hubs	15,700
A.3.0109/1	o	o	Tool for resting the pins of puller A.3.0109 for withdrawal of disc-brake axle shaft	4,300
A.3.0115	o	o	Puller of differential housing bearing cup	6,000
A.3.0150	o	o	Base for pulling of pinion rear bearing cone	5,500

Tool No.	Applies to		Description	Price
	Giulia	1750		
A.3.0160	o	o	Driver of oil seal ring into axle tubes	1,100
A.3.0167	o	o	Driver of oil seal ring onto pinion	2,000
A.3.0168	o	o	Driver of pinion front bearing cone	2,500
A.3.0207	o	o	Puller-driver of pinion bearing cups	11,300
A.3.0208	o	o	Driver of differential housing bearing cones and cups	4,200
A.5.0104	o	o	Wrench for pinion yoke ring nut	2,200
C.5.0100	o	o	Lever for checking preload of pinion bearings	6,500
C.5.0116	o	o	Support for dial gauge	3,600
C.6.0101	o	o	Reference gauge for pinion positioning	9,800
C.6.0102	o	o	Gauge for differential housing shim thickness	13,700
C.6.0114	o	o	Tool for checking pinion position	4,700
C.6.0115	o	o	Tool for adjusting pinion-to-ring gear clearance	13,000
<u>FRONT AND REAR SUSPENSIONS</u>				
A.2.0143	o	o	Tool for removing rear suspension springs	10,500
A.2.0169	o	o	Tool for removing front suspension springs	16,800
A.2.0178	o	o	Driver of bolt into rear trailing arm	800
A.3.0156	o	o	Puller of upper pin from stub axle	3,400
A.3.0157	o	o	Puller of lower pin of stub axle and ball joints	3,900
A.3.0159	o	o	Driver of self-lubricating bushes into front suspension arms	1,250
A.3.0163	o	o	Puller of I-arm rubber bushings	6,800
A.3.0164	o	o	Driver of I-arm rubber bushings	850
A.3.0211	o	o	Puller and driver of rear suspension rubber bushings	7,800
A.3.0214	o	o	Puller and driver of rubber bushing into front suspension upper arm	4,800
A.3.0243	o	o	Tool for removing and installing rubber bushings of stabilizer rod links	2,300
A.5.0161	o	o	Wrench for tightening front cross-member bolts	1,100
C.6.0125	o	o	Tool for checking car "trim"	21,000

Tool No.	Applies to		Description	Price
	Giulia	1750		
<u>WHEELS</u>				
A.3.0116	o	o	Driver of wheel hubs onto stub axles	2,250
A.3.0124	o	o	Puller and driver of wheel hub caps	3,600
A.3.0192	o	o	Driver of front wheel packing	1,700
C.5.0117	o	o	Support of dial gauge for checking wheel bearing clearance	9,000
<u>"ATE" BRAKES</u>				
A.2.0147	o	o	Tool for resetting brake pistons	3,000
A.2.0148/1	o	o	Pliers for rotating rear brake pistons	2,000
A.2.0149	o	o	Template for positioning brake pistons	800
A.2.0150	o	o	Puller of friction pads	1,000
A.2.0151	o	o	Tool for checking brake disc squareness	2,200
A.2.0159	o	o	Pliers for rotating front brake pistons	2,200
A.2.0160	o	o	Template for positioning brake pistons	800
<u>STEERING GEAR AND LINKAGE</u>				
A.3.0119	o	o	Puller of steering arm	4,700
A.3.0158/1	o	o	Puller of steering wheel (1300 - T.I. - G.I.)	1,900
A.5.0154	o	o	Wrench for steering column jacket screws (3-4-5 mm hex)	1,200
C.6.0121	o	o	Support of dial gauge for "Burman" steering box adjustment	1,900

## STANDARD LOT "C" OF SPECIAL TOOLS for GIULIA and 1750 models

Tool No.	Applies to		Description	Price
	Giulia	1750		
<u>ENGINE</u>				
A.2.0103	o	o	Caulking tool for plugs of crankshaft oil ducts	800
A.2.0108/1	o	o	Tool for cylinder head support in a vice	5,600
A.2.0117	o	o	Tool for retaining cylinder barrels (set of two)	1,000
A.2.0120	o	o	Support for timing checking dial gauge	3,900
A.2.0121	o	o	Tool for supporting valves in cylinder head	1,250
A.2.0122	o	o	Tool for turning crankshaft	3,600
A.2.0145	o	o	Tool for locking the flywheel	2,650
A.2.0146	o	o	Tool for removing the head from cylinder block	2,000
A.2.0152	o		Tool for tightening ignition switch ring nuts	1,200
A.2.0179	o	o	Pointer for protractor	1,250
A.2.0180	o	o	Adapter (set of two) } to be used with protractor C.6.0111	1,250
A.3.0103/1	o	o	Lever	2,000
A.3.0103/2	o	o	Support	1,500
A.3.0103/6	o	o	Retainer } tools for removing the valve cotters	1,000
A.3.0113	o	o	Tool for driving rubber plugs into crankcase	5,400
A.3.0133	o	o	Driver of exhaust valve guides	1,200
A.3.0134	o	o	Puller of valve guides from cylinder head	1,200
A.3.0136	o	o	Base for extraction of water pump impeller	2,000
A.3.0137	o	o	Driver of slinger onto water pump shaft	800
A.3.0139/1	o	o	Lever	1,800
A.3.0139/2	o	o	Bracket } tools for removing the rear main bearing cap	1,200
A.3.0146	o	o	Driver of oil seal ring into front cover	1,500
A.3.0147	o	o	Puller of water pump pulley	2,550
A.3.0155	o	o	Guide for driving the circlip onto water pump shaft	500
A.3.0177	o	o	Driver of water pump sealing ring	1,700
A.3.0178	o	o	Driver of rear crankshaft oil seal ring	3,800
A.3.0182	o	o	Tool for removal of main bearing caps	5,800

Tool No.	Applies to		Description	Price
	Giulia	1750		
A.3.0210	o	o	Puller { timing chain idler sprocket bushing crankshaft rear bushing oil pressure relief valve	6,700
A.3.0244	o	o	Driver of valve guide seals	1,000
A.3.0246	o	o	Driver of intake valve guides	1,150
A.3.0247	o	o	Puller of valve guide seals	3,500
A.4.0112	o	o	Guide for reaming of idler sprocket bushes	9,200
A.5.0103	o	o	Wrench for turning camshafts	2,000
A.5.0106	o	o	Wrench for oil filter and for gearbox/differential oil drain plugs	1,250
A.5.0108	o	o	Wrench for carburettor securing nuts	600
A.5.0115	o	o	Adapter, spark plugs-to-torque wrench	800
A.5.0126	o	o	Wrench for crankshaft pulley nut	1,600
A.5.0133	o	o	Wrench for intake manifold nuts	800
C.5.0111/1	o	o	Support for valve adjusting pad selection	3,200
C.6.0111	o	o	Protractor for valve timing	14,000
C.6.0122	o	o	Tool for checking the T.D.C.	5,800
C.6.0123	o	o	Feeler gauge for checking valve clearance	11,000
C.6.0124	o	o	Tool for scribing reference lines on camshaft journal bearings	21,000
C.6.0148	o	o	Tool for checking the projection of barrels or pistons from cylinder block	15,700
C.8.0100	o		Ring for zero-setting of cylinder barrel bore gauge	11,500
C.8.0103	o	o	Gauge for checking the alignment of idler sprocket bushings	7,700
C.8.0104		o	Ring for zero-setting of cylinder barrel bore gauge	12,600
U.2.0040	o	o	Reamer (rougher) for boring the idler sprocket bushings in cylinder block	12,700
U.2.0041	o	o	Reamer (finisher) for boring the idler sprocket bushings in cylinder block	12,700
<u>CLUTCH</u>				
A.4.0103	o	o	Spindle for clutch disc centering	1,700
C.6.0104	o	o	Tool for clutch overhauling	17,000
C.6.0146	o	o	Tool for checking the clutch pedal travel	27,500

Tool No.	Applies to		Description	Price
	Giulia	1750		
			<u>STANDARD GEARBOX</u>	
A.3.0118	o	o	Puller-driver of rubber bushing	6,900
A.3.0180	o	o	Driver of oil seal ring into rear cover	1,800
A.3.0185	o	o	Clamp for retaining mainshaft	4,700
A.3.0212	o	o	Puller of differential bearings and outer race of gearbox rear cover	5,000
A.5.0127	o	o	Wrench for securing output shaft yoke	1,200
			<u>PROPELLER SHAFT</u>	
A.2.0124	o	o	Tool for removing and refitting flexible joint	2,500
A.5.0162	o	o	Wrench for flexible and U-joints	1,600
			<u>REAR AXLE - DIFFERENTIAL</u>	
A.2.0144	o	o	Tool for stopping pinion	3,500
A.3.0109	o	o	Puller of axle shafts and puller-driver of axle shaft bearings and front wheel hubs	15,700
A.3.0109/1	o	o	Tool for resting the pins of puller A.3.0109 for withdrawal of disc-brake axle shaft	4,300
A.3.0115	o	o	Puller of differential housing bearing cup	6,000
A.3.0150	o	o	Base for pulling of pinion rear bearing cone	5,500
A.3.0160	o	o	Driver of oil seal ring into axle tubes	1,100
A.3.0167	o	o	Driver of oil seal ring onto pinion	2,000
A.3.0168	o	o	Driver of pinion front bearing cone	2,500
A.3.0170	o	o	Driver of pinion rear bearing cone	1,250
A.3.0207	o	o	Puller-driver of pinion bearing cups	11,300
A.3.0208	o	o	Driver of differential housing bearing cones and cups	4,200
A.3.0240	o	o	Puller of axle shaft bearings	9,800
A.3.0241	o	o	Driver of axle shaft bearings	5,400
A.5.0104	o	o	Wrench for pinion yoke ring nut	2,200

Tool No.	Applies to		Description	Price
	Giulia	1750		
A.5.0120	o	o	Wrench for ring nuts of axle shaft bearings	1,800
A.5.0146	o	o	Wrench for axle bearing flange nuts	3,000
C.5.0100	o	o	Lever for checking preload of pinion bearings	6,500
C.5.0116	o	o	Support for dial gauge	3,600
C.6.0101	o	o	Reference gauge for pinion positioning	9,800
C.6.0102	o	o	Gauge for differential housing shim thickness	13,700
C.6.0114	o	o	Tool for checking pinion position	4,700
C.6.0115	o	o	Tool for adjusting pinion-to-ring gear clearance	13,000
<hr/> <u>FRONT AND REAR SUSPENSIONS</u> <hr/>				
A.2.0143	o	o	Tool for removing rear suspension springs	10,500
A.2.0169	o	o	Tool for removing front suspension springs	16,800
A.2.0178	o	o	Driver of bolt into rear trailing arm	800
A.3.0156	o	o	Puller of upper pin from stub axle	3,400
A.3.0157	o	o	Puller of lower pin of stub axle and ball joints	3,900
A.3.0159	o	o	Driver of self-lubricating bushes into front suspension arms	1,250
A.3.0163	o	o	Puller of T-arm rubber bushings	6,800
A.3.0164	o	o	Driver of T-arm rubber bushings	850
A.3.0211	o	o	Puller and driver of rear suspension rubber bushings	7,800
A.3.0214	o	o	Puller and driver of rubber bushing into front suspension upper arm	4,800
A.3.0243	o	o	Tool for removing and installing rubber bushings of stabilizer rod links	2,300
A.5.0161	o	o	Wrench for tightening front cross-member bolts	1,100
C.6.0125	o	o	Tool for checking car "trim"	21,000
<hr/> <u>WHEELS</u> <hr/>				
A.3.0116	o	o	Driver of wheel hubs onto stub axles	2,250
A.3.0120	o	o	Puller and driver of wheel bearing cups	2,500
A.3.0124	o	o	Puller and driver of wheel hub caps	3,600

Tool No.	Applies to		Description	Price
	Giulia	1750		
A.3.0192	o	o	Driver of front wheel packing	1,700
C.5.0117	o	o	Support of dial gauge for checking wheel bearing clearance	9,000
<u>"ATE" BRAKES</u>				
A.2.0147	o	o	Tool for resetting brake pistons	3,000
A.2.0148/1	o	o	Pliers for rotating rear brake pistons	2,000
A.2.0149	o	o	Template for positioning brake pistons	800
A.2.0150	o	o	Puller of friction pads	1,000
A.2.0151	o	o	Tool for checking brake disc squareness	2,200
A.2.0159	o	o	Pliers for rotating front brake pistons	2,200
A.2.0160	o	o	Template for positioning brake pistons	800
<u>STEERING GEAR AND LINKAGE</u>				
A.3.0119	o	o	Puller of steering arm	4,700
A.3.0158/1	o	o	Puller of steering wheel (1300 - T.I. - G.T.)	1,900
A.5.0154	o	o	Wrench for steering column jacket screws (3-4-5 mm hex)	1,200
C.6.0121	o	o	Support of dial gauge for "Burman" steering box adjustment	1,900

**COMPLEMENTARY LOT "A" of  
SPECIAL TOOLS for 2600 models**

Tool No.	Description	Price
	<u>ENGINE</u>	
A.2.0118	Tool (set of three) for retaining cylinder barrels	1,700
A.3.0103/8	Tool for removing valve cotters	950
A.3.0139/3	Tool for removal of rear main bearing cap	1,000
A.3.0140	Driver of rear oil seal ring onto crankshaft	3,000
A.3.0145	Driver of rubber plugs into crankcase	5,400
	<u>CLUTCH</u>	
A.5.0113	Wrench for tie-rod adjusting nut	600
	<u>REAR AXLE</u>	
A.3.0141	Driver of oil seal ring into axle tubes	1,100
A.3.0179	Driver of oil seal ring into pinion	1,800
A.5.0114	Wrench for pinion yoke ring nut	2,500
	<u>WHEELS</u>	
A.3.0117	Driver of wheel hubs	2,300
	<u>STEERING GEAR AND LINKAGE</u>	
A.3.0104	Puller of steering wheel	2,500

**COMPLEMENTARY LOT "B" of  
SPECIAL TOOLS for 2600 models**

Tool No.	Description	Price
<u>ENGINE</u>		
A.2.0097	Tool for locking and loosening the oil filter	300
A.2.0118	Tool (set of three) for retaining cylinder barrels	1,700
A.3.0103/8	Tool for removing valve cotters	950
A.3.0132	Driver of valve guides	1,300
A.3.0139/3	Tool for removal of rear main bearing cap	1,000
A.3.0140	Driver of rear oil seal ring onto crankshaft	3,000
A.3.0144	Puller of valve guides from cylinder head	1,200
A.3.0145	Driver of rubber plugs into crankcase	5,400
<u>CLUTCH</u>		
A.4.0106	Spindle for disc centering	2,000
A.5.0113	Wrench for tie rod adjusting nut	600
<u>REAR AXLE - DIFFERENTIAL</u>		
A.3.0141	Driver of oil seal ring into axle tubes	1,100
A.3.0149	Puller - driver of pinion rear bearing cup	3,100
A.3.0152	Driver of pinion front bearing cone	3,000
A.3.0179	Driver of oil seal ring onto pinion	1,800
A.5.0114	Wrench for pinion yoke ring nut	2,500
C.6.0113	Tool for checking of pinion position	4,100
<u>SUSPENSION</u>		
A.3.0153	Puller of reaction triangle arms	2,500
A.3.0176	Puller of king pins	2,000

Tool No.	Description	Price
A.3.0117	<u>WHEELS</u> Driver of wheel hubs	2,300
A.3.0104	<u>STEERING GEAR AND LINKAGE</u> Puller of steering wheel	2,500

**COMPLEMENTARY LOT "C" of  
SPECIAL TOOLS for 2600 models**

Tool No.	Description	Price
<u>ENGINE</u>		
A.2.0097	Tool for locking and loosening the oil filter	300
A.2.0118	Tool (set of three) for retaining cylinder barrels	1,700
A.2.0125	Pointer	1,300
A.2.0126	Spacer (set of two) } to be used with protractor C.6.0111	400
A.3.0103/8	Tool for removing valve cotters	950
A.3.0132	Driver of valve guides	1,300
A.3.0138	Driver of oil seal ring into front cover	1,600
A.3.0139/3	Tool for removal of rear main bearing cap	1,000
A.3.0140	Driver of rear oil seal ring onto crankshaft	3,000
A.3.0144	Puller of valve guides from cylinder head	1,200
A.3.0145	Driver of rubber plugs into crankcase	5,400
A.4.0113	Guide for reaming the idle sprocket bushings	11,000
A.5.0114	Wrench for ring nut of crankshaft pulley	2,500
A.5.0116	Wrench for cylinder head nuts	850
<u>CLUTCH</u>		
A.4.0106	Spindle for disc centering	2,000
A.5.0113	Wrench for tie-rod adjusting nut	600
<u>REAR AXLE - DIFFERENTIAL</u>		
A.3.0141	Driver of oil seal ring into axle tubes	1,100
A.3.0148	Puller driver of pinion front bearing cup	3,000
A.3.0149	Puller driver of pinion rear bearing cup	3,100
A.3.0151	Driver of differential housing bearing cones and pinion rear bearing cone	1,100
A.3.0152	Driver of pinion front bearing cone	3,000

Tool No.	Description	Price
A.3.0179	Driver of oil seal ring onto pinion	1,800
A.5.0131	Wrench for ring nuts of differential housing bearings	800
A.5.0132	Wrench for ring nuts of axle shaft bearing	1,400
C.6.0113	Tool for checking of pinion position	4,100
<hr/> <u>FRONT AND REAR SUSPENSIONS</u> <hr/>		
A.3.0153	Puller of reaction triangle arms	2,500
A.3.0176	Puller of king pins	2,000
A.5.0134	Wrench for grease fittings of king pins	850
<hr/> <u>WHEELS</u> <hr/>		
A.3.0117	Driver of wheel hubs	2,300
A.3.0121	Puller-driver of wheel bearing cups	2,600
<hr/> <u>STEERING GEAR AND LINKAGE</u> <hr/>		
A.3.0104	Puller of steering wheel	2,500
C.5.0112	Lever for checking pre-load of steering box bearings	2,400

GENERAL TOOLS	
SPECIAL TOOLS	<b>X</b>
MACHINERY	
EQUIPMENT	
MISCELLANEOUS	

# Alfa Romeo

DIREZIONE ASSISTENZA CLIENTI

DATE

1-3-1969

SEQUENT NUMBER

135

## Tooling News

1750

### CHECKING THE CLUTCH PEDAL TRAVEL

**C.6.0146**

- 1 Check the position of clutch pedal with respect to the brake pedal  
(refer to I.S. no. 12.68.4.2)
- 2 Slacken the setscrews "C" and "D"
- 3 Mount the tool outside the gearbox and lock in place with the wingnut "A". The sensing needle "B" should be brought in contact with the "fork ended" disengagement lever as near as possible to the push rod
- 4 Set to zero the scale and tighten the setscrew "C"

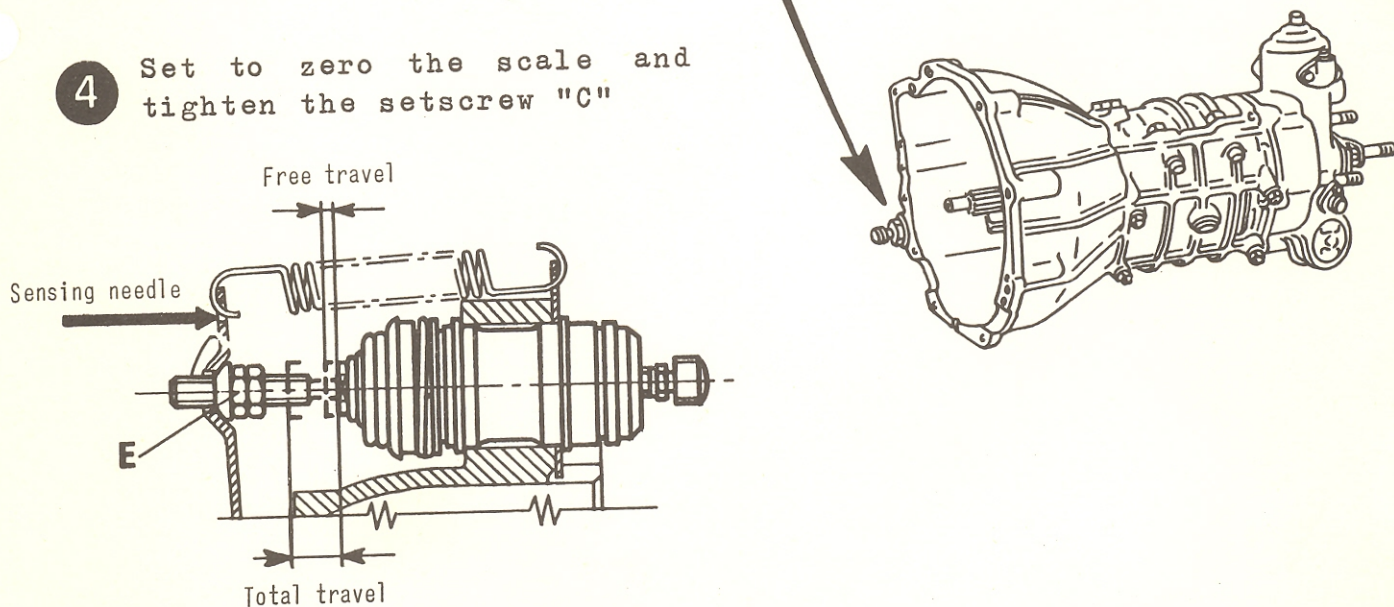
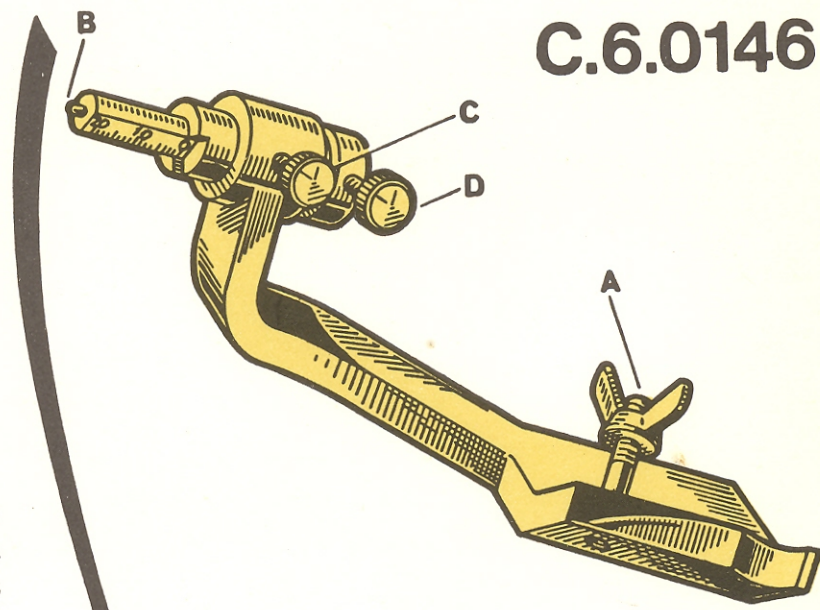

- 5 Depress the clutch pedal and check the travel. Adjust the nuts "E", if necessary.

GENERAL TOOLS

SPECIAL TOOLS

X

MACHINERY

EQUIPMENT

MISCELLANEOUS

# Alfa Romeo

DIREZIONE ASSISTENZA CLIENTI

DATE

1-3-1969

SEQUENT NUMBER

140

## Tooling News

Giulia - 1750

### CHECKING THE VALVE TIMING

- 1 Screw in and tighten securely the adapters "A" onto the lower studs on crankcase at flywheel side

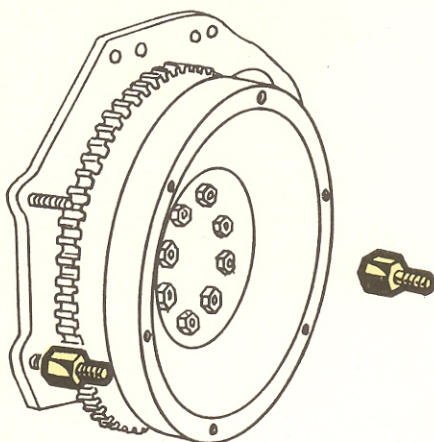

### C.6.0111

- 2 Mount the protractor, tool no. C.6.0111, by the holes "B". Lock in place with nuts "C".

- 3 Fit properly the pointer A.2.0179 to the flywheel as shown below and lock it in place with one of the clutch attaching screws. Position the pointer in height and depth by means of the screw "D" so that readings can be easily taken.

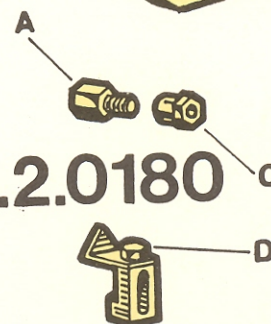
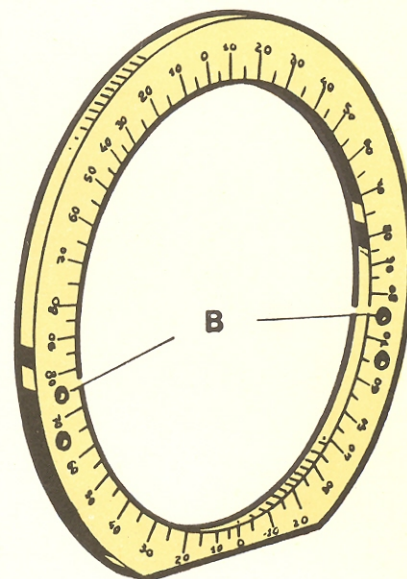

### A.2.0180

### A.2.0179

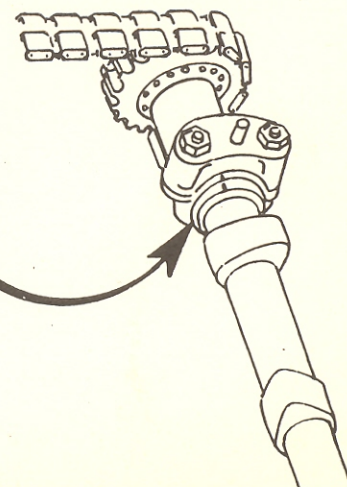
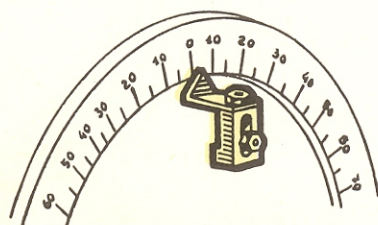

GENERAL TOOLS	
SPECIAL TOOLS	<b>X</b>
MACHINERY	
EQUIPMENT	
MISCELLANEOUS	

# Alfa Romeo

DIREZIONE ASSISTENZA CLIENTI

DATE

1-3-1969

SEQUENT NUMBER

141

## Tooling News

Giulia - 1750

### PULLING AND DRIVING THE VALVE GUIDE SEALS

#### PULLING:

- 1 Unscrew the handle "A" until it reaches the end of screw "B"
- 2 Push in handle and screw so that jaws protrude from the tool

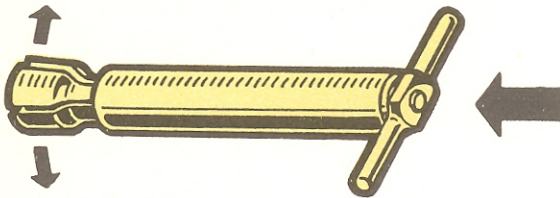

- 3 Insert the tool in the valve guide seat and slide the spacer "C" until it abuts against the cylinder head

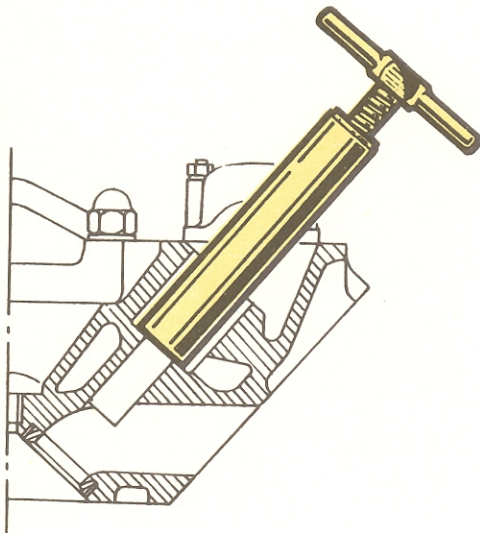

**A.3.0247**

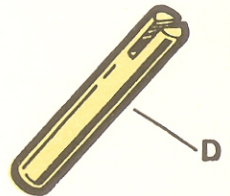
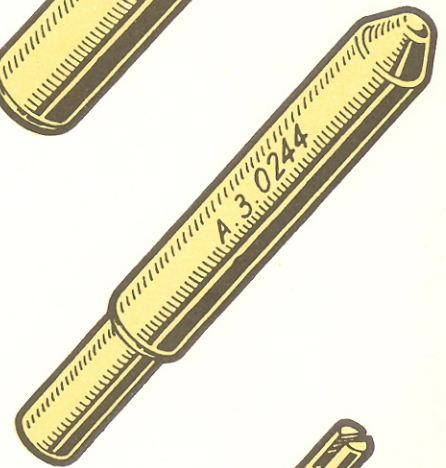
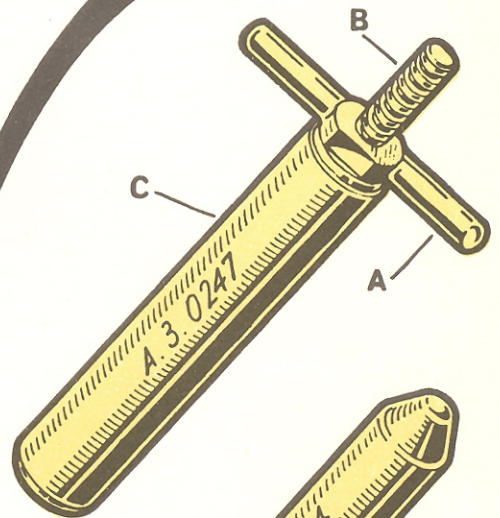

**A.3.0244**

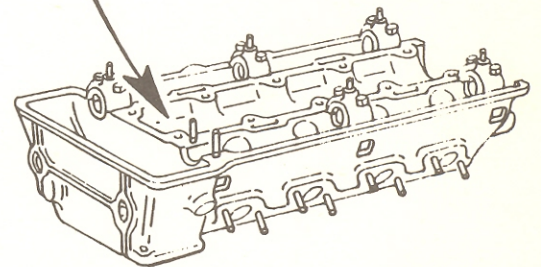

- 4 Rotate the handle "A" to pull out the valve guide seal

#### DRIVING:

- 5 Fit the seal onto the tool no. A.3.0244 and center the seal over the valve guide (either with or without the aid of pin "D").
- 6 Drive the seal in position by tapping with a mallet

GENERAL TOOLS

**X**

SPECIAL TOOLS

MACHINERY

EQUIPMENT

MISCELLANEOUS

*Alfa Romeo*

DIREZIONE ASSISTENZA

*Tool Bulletin*

DATE

22-11-1968

SEQUENT NUMBER

143

All models

**C.2.0009****TESTING THE ANTIFREEZE MIXTURE**GENERAL

To test the freezing point of the antifreeze mixture, the test temperature should be between 20 and 80°C. If not such a condition must be restored.

TESTING PROCEDURE

- 1** Slip the hose "Z" on the bottom end "V" of the thermo-densimeter.
- 2** Remove the radiator filler plug.
- 3** Draw in coolant by means of the rubber bulb until the glass tube "T" is about half full.
- 4** On the scale "S" read the letter at coolant level.

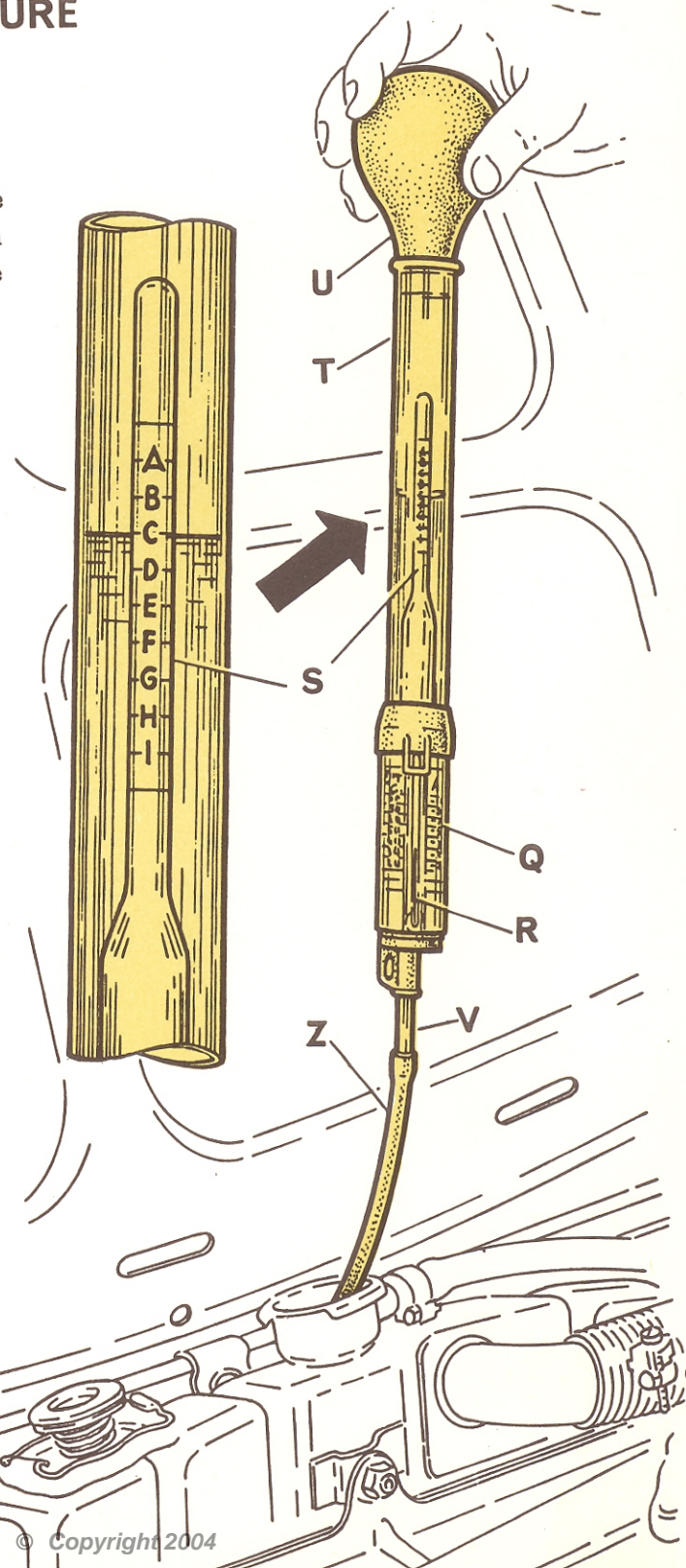

5

Let thermometer "R" settle, then, on table "Q", read the freezing point of mixture in correspondence of the temperature indicated by the thermometer and the column headed by the letter previously read on the densimeter scale.

For example:

If the densimeter scale reads "C" and the thermometer scale 50°C, the freezing point of the mixture being tested is -15°C as found in correspondence of temperature line and density column.

A	B	C	D	E	F	G	H	temper. °C
-11	-17	-25	-35	-46				80°
-8	-15	-22	-31	-43	-53			70°
-7	-12	-19	-27	-37	-47			60°
-5	-9	-15	-22	-30	-40	-49		50°
-3	-6	-12	-17	-25	-33	-43	-53	40°
-2	-5	-9	-14	-20	-27	-36	-45	30°
-2	-3	-7	-12	-17	-24	-31	-40	20°

When intermediate values of temperature and density are read, the freezing point can be obtained by interpolation.

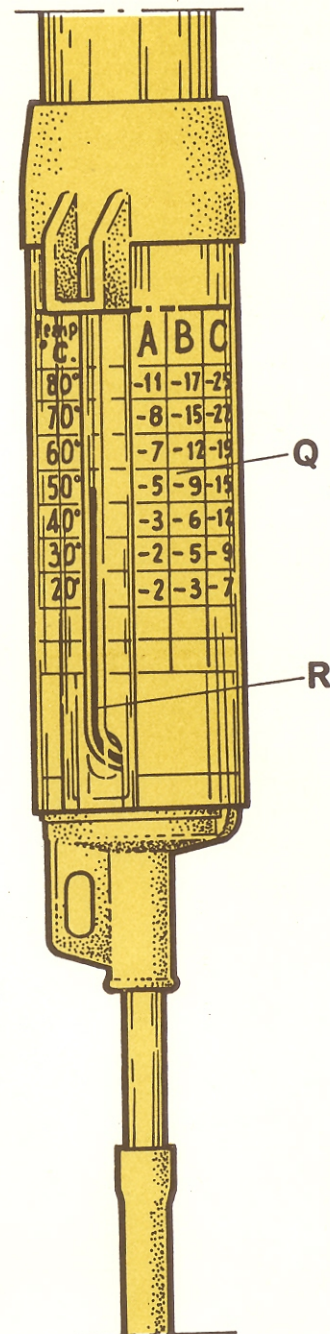

N.B. - Should additional liquid be added to modify the characteristic of the mixture, before testing again the freezing point, run the engine for about 5 minutes for a thorough mixing of the components. © Copyright 2004

GENERAL TOOLS	
SPECIAL TOOLS	X
MACHINERY	
EQUIPMENT	
MISCELLANEOUS	

# Alfa Romeo

DIREZIONE ASSISTENZA CLIENTI

DATE  
18-3-1969

SEQUENT NUMBER  
144

1300-1600-1750  
2600-A.15-A.19  
A.38-F.20

## Tooling News

### TOOL FOR CHECKING THE PROJECTIONS OF BARRELS OR PISTONS

### C.6.0148

- 1 On the special tool mount two dial gauges with a 10 mm range (std.no.7600.31002) or a 3 mm range (std.no.7600.31001 with a 20 mm extension).
- 2 By means of the setscrew "A" lock the dial gauges in such a way that the sensing needles can work midway in the reading range.
- 3 Rest the tool on a face plate and zero set the dials.
- 4 Clean carefully the top surfaces of cylinder block and barrels.
- 5 Retain in place the barrels with the suitable tool (refer to tool Bulletin no. 77/1).
- 6 Rest the tool, set to zero as per 3 above, on the cylinder block top as shown; make sure the tool is aligned with the barrel center line.
- 7 Check whether the readings meet the specifications.
- 8 Repeat the steps 6 and 7 for each barrel.

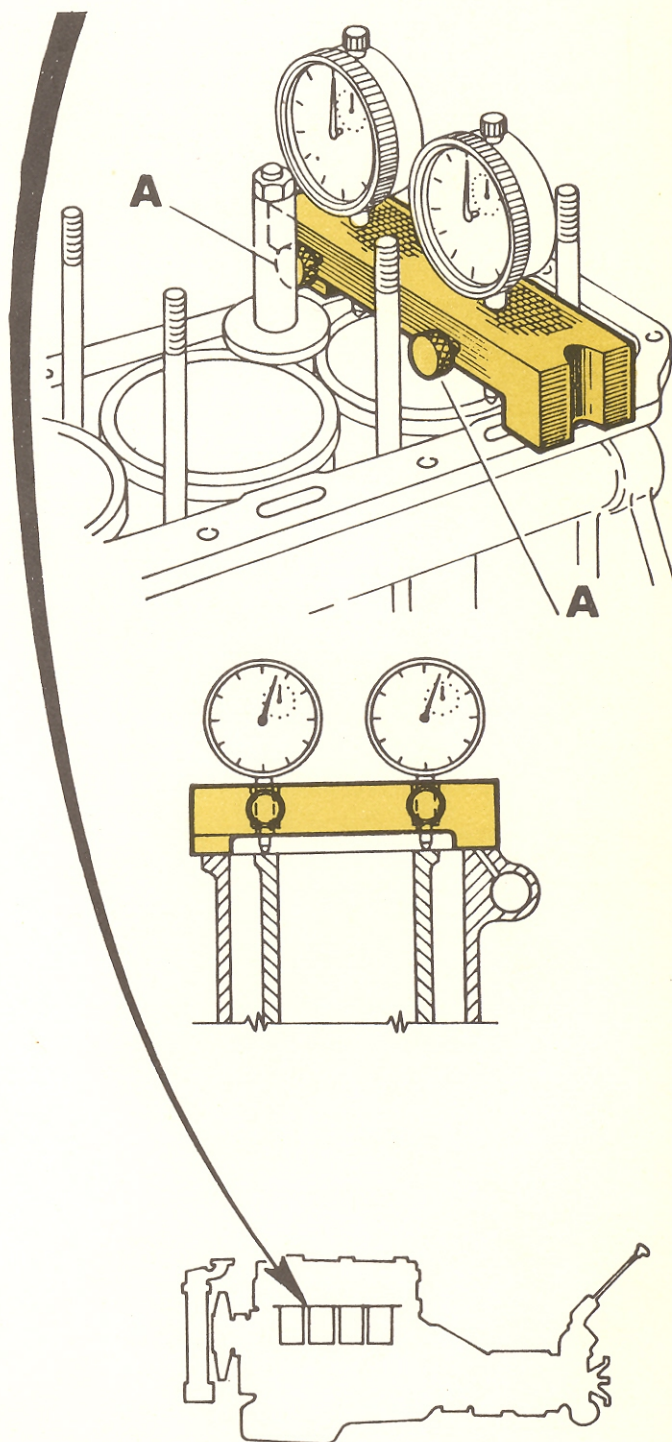

N.B. - The tool C.6.0148 deletes and supersedes the existing tools A.7.0110 and A.7.0111.

GENERAL TOOLS	
SPECIAL TOOLS	
MACHINERY	<b>X</b>
EQUIPMENT	
MISCELLANEOUS	

# Alfa Romeo

DIREZIONE ASSISTENZA CLIENTI

DATE

18-3-1969

SEQUENT NUMBER

**145**

## Tooling News

All models

### VACUUM PUMP FOR "WATER" TESTING THE CARS

## M.6.0101

- 1 Install the "dummy window" "A" on the door. Raise the car window until it seals perfectly against "A"
- 2 Close all doors and blank off any air passage (like the flow away slits "B" on 1750 Saloon)
- 3 Fill with water tinted by some drops of china ink the U-shaped tube of vacuum meter "C" up to about the midpoint of scale; then connect the plastic hose "D" to either of the adapters of meter
- 4 Connect the hose "D" also to the small adapter on dummy window "A"
- 5 Connect the vacuum pump hose "E" to the large adapter on dummy window "A"
- 6 Plug the cord "F" in a power source. Make sure the terminals of electric motor "G" are so connected as to meet the current supply voltage
- 7 Start the vacuum pump by operating the switch "H"
- 8 Adjust the vacuum control "I" until a reading of 30 mm is shown on the scale "L" of vacuum meter "C"
- 9 Spray water as shown over all those areas to be tested (doors, lids, etc.)
- 10 Switch off the pump and carefully inspect the inside of car for water see page

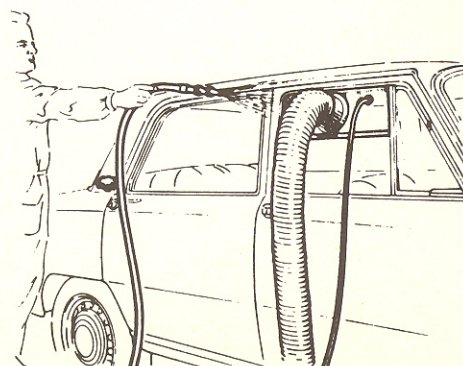
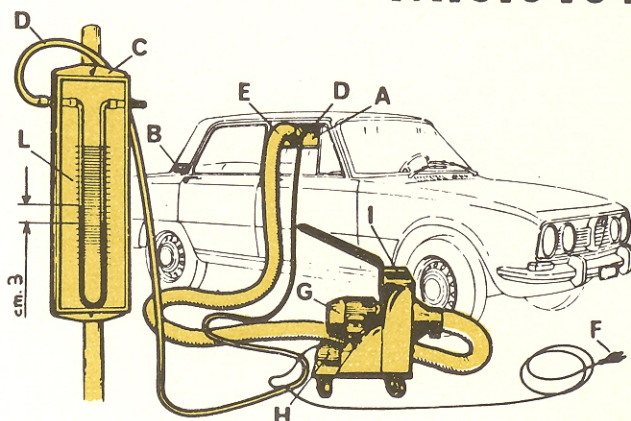

GENERAL TOOLS

SPECIAL TOOLS

X

MACHINERY

EQUIPMENT

MISCELLANEOUS

# Alfa Romeo

DIREZIONE ASSISTENZA CLIENTI

DATE

18-3-1969

SEQUENT NUMBER

146

## Tooling News

1750-GIULIA

### TOOL FOR DRIVING PISTON & RING ASSEMBLIES INTO BARRELS

### A. 3.0252

- 1 Reuse the bottom part of discarded barrels of suitable I.D. for a height of about 70 mm.

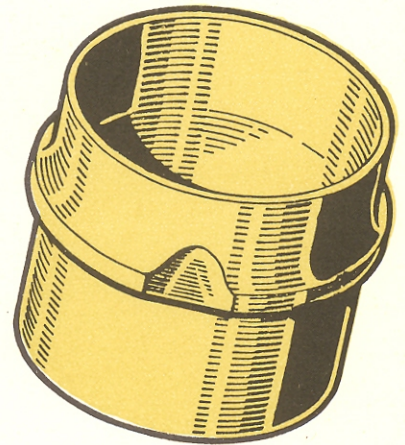
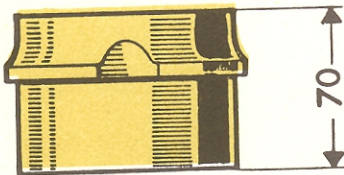

- 2 Have the bore tapered as shown so that the top edge thickness is 2 mm and the taper about 5 degrees.

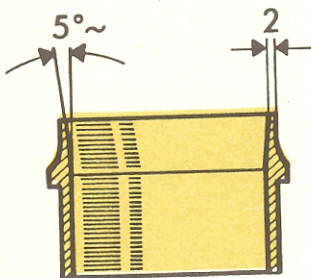

- 3 Mark the tool with its own I.D.

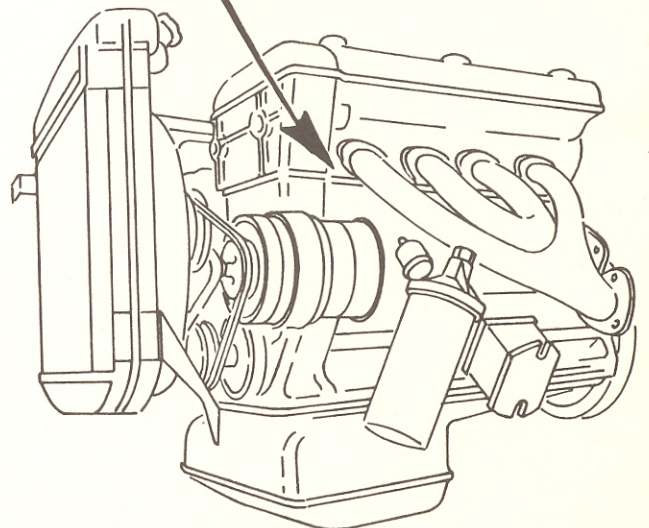
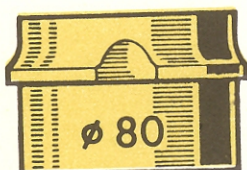

A.3.0252 74 mm I.D.

A.3.0252/1 78 mm I.D.

A.3.0252/2 80 mm I.D.

GENERAL TOOLS	
SPECIAL TOOLS	X
MACHINERY	
EQUIPMENT	
MISCELLANEOUS	

# Alfa Romeo

DIREZIONE ASSISTENZA CLIENTI

DATE

7-5-1969

SEQUENT NUMBER

150

GIULIA -  
1750

Tooling News

## PULLING AND DRIVING THE AXLE SHAFT BEARING ON CARS WITH "ATE" BRAKES

Pulling:

- 1 Clamp the puller A.3.0240 in a vice as shown. Lock in proper position the tool flange on plate "A" with screws "B".

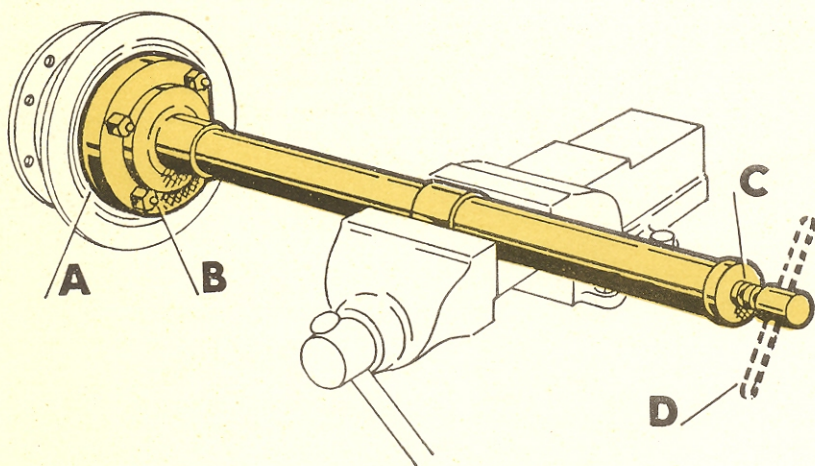

- 2 Rotate the screw "C" with a tommy bar "D" to pull plate and bearing apart from axle shaft.

Driving:

- 3 Drive the bearing onto the axle shaft by acting on the bearing inner race with the driver A.3.0241.

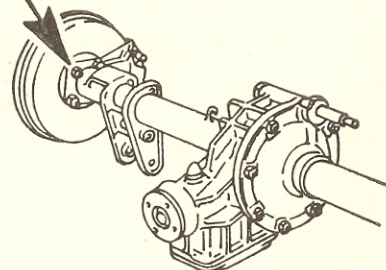
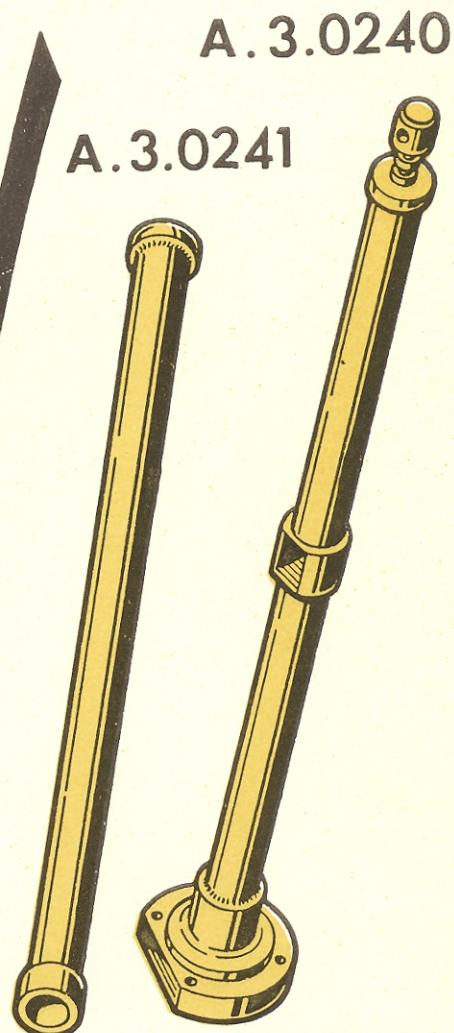
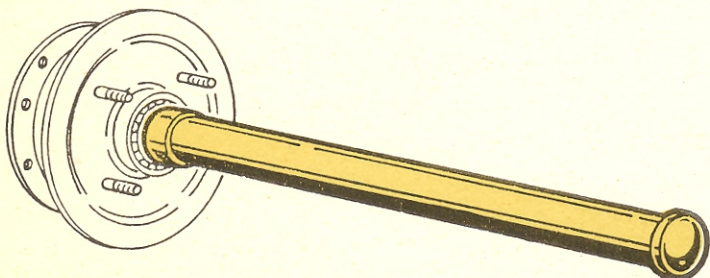

GENERAL TOOLS	X
SPECIAL TOOLS	
MACHINERY	
EQUIPMENT	
MISCELLANEOUS	

# Alfa Romeo

DIREZIONE ASSISTENZA

## Tool Bulletin

DATE

30 - 4 - 1976

SEQUENT NUMBER

176

All Models

### RECUTTING THE VALVE SEATS WITH A CUTTER

A.1.0002

1

The kit consists of the following components which are accommodated in a box:

- a tool head with a 30° tilt for bores up to 50 mm
- a tool head with 45° tilt for bores up to 50 mm
- a support with clamp for fixing to cylinder head
- a set of pilot spindles, elastic bushes (for valve guides with bores ranging from 7 to 12.9 mm) and cutters with hard metal inserts.

Detailed directions on the use of this equipment are also provided. We recommend that these directions be strictly complied with.

2

Recutting of valve seats is performed through a by-hand turning (as opposed to the grinding outlined in T.B. 177) using a sliding head (at 45° or 30°) rotated on a steel rod. Such a rod is fitted coaxially with the valve guide. The sliding head, bearing a hard metal cutter, is micrometrically operated through a pinion and a worm screw. Recutting starts at the lower edge of valve seat and ends at the upper edge of valve seating surface.

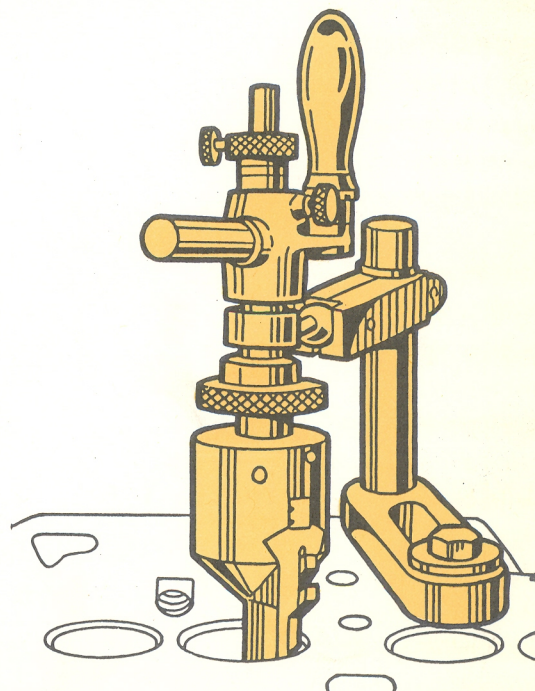
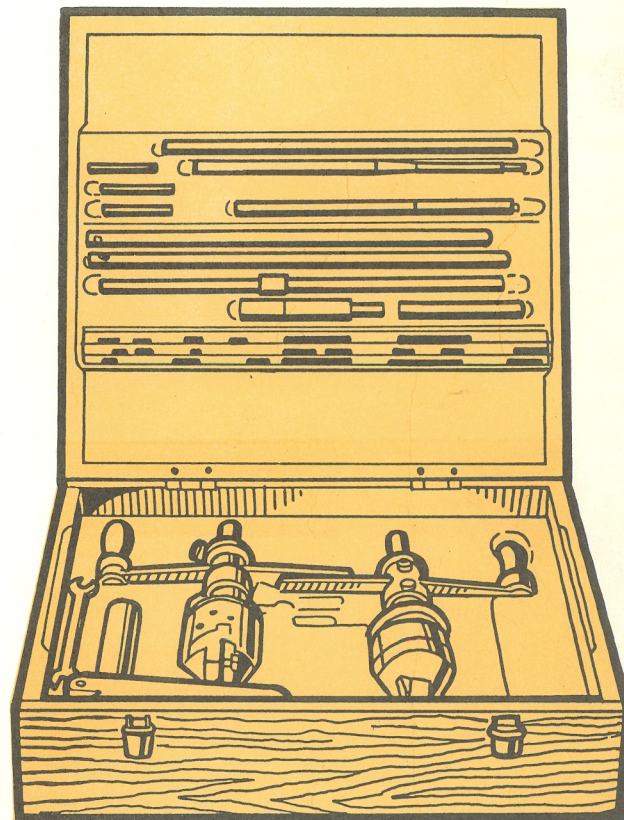

Deletes and supersedes T.B.  
no. 14 dated 1/12/1966

GENERAL TOOLS	X
SPECIAL TOOLS	
MACHINERY	
EQUIPMENT	
MISCELLANEOUS	

# Alfa Romeo

DIREZIONE ASSISTENZA

## Tool Bulletin

DATE

30 - 4 - 1976

SEQUENT NUMBER

177

All models

### RECUTTING THE VALVE SEATS WITH A GRINDER

G.1.0003

1

The kit consists of the following components which are accommodated in a box:

- one grinder operating at 1200 rpm fed by 220 V current
- one calibrated tool for trimming the grinding wheels with a diamond
- twelve grinding wheels
- two grinding wheel shafts
- five expansion guide bushings, 5.95 - 7 - 7.75 - 8.5 - 9.4 mm in size
- one 4 mm hex. wrench
- one extractor of bushings

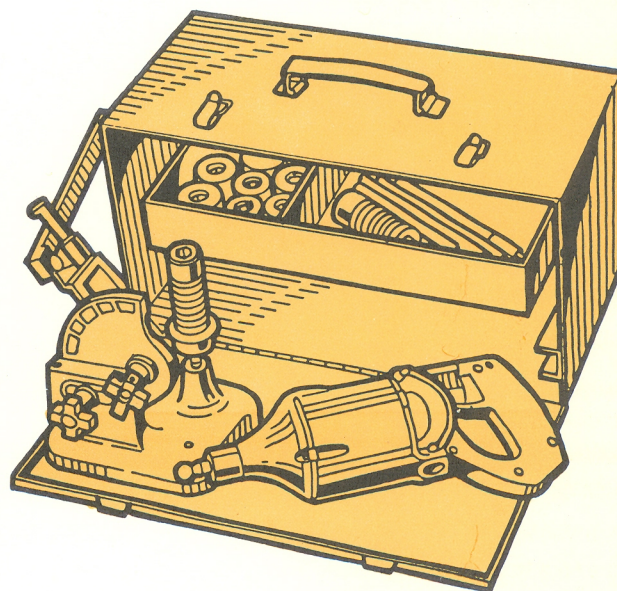

Detailed directions on the use of this equipment are also provided. We recommend that these directions be strictly complied with.

2

Regrinding of valve seats is performed by means of a grinding wheel driven by the grinder through a coupling.

The drive shaft is guided by a pilot spindle which fits into the valve guide by an expansion bushing.

The grinding wheel, in addition to revolving about its axis, moves up and down along its axis centreline. Combining the two movements together, which is obtained by applying a downward pressure to the grinder, allows to cool the grinding wheel and to dispel the abrasive powder resulting in a better finish of the surface being reground.

